



## 2M-4 Storm Sewer Sizing

### A. Introduction

The purpose of this section is to outline the basic hydraulic principles in order to determine the storm sewer size. The elements covered include basic flow formulas (Bernoulli Equation and Manning Equation), hydraulic losses, and hydraulic design of storm sewers.

### B. Flow formulas

#### 1. Continuity Equation

$$Q = VA$$

Equation 1

where

Q = pipe discharge in cubic feet per second

V = pipe velocity in feet per second

A = pipe cross sectional area in square feet

#### 2. Bernoulli Equation (conservation of energy)

The law of conservation of energy as expressed by the Bernoulli Equation is the basic principle most often used in hydraulics. This equation may be applied to any conduit with a constant discharge. Friction flow formulas such as the Manning's Equation have been developed to express the rate of energy dissipation as it applies to the Bernoulli Equation. The theorem states that the energy head at any cross-section must equal that in any other downstream section plus the intervening losses.

In open conduits, the flow is primarily controlled by the gravitational action on the moving fluid, which overcomes the hydraulic energy losses. The hydraulic grade line (HGL) in open conduit flow is equal to the water surface. For the case of pressure flow, the HGL is the piezometric surface, i.e. the height to which water will rise in a piezometer. It is often referred to as the piezometric head line (PHL). The energy grade line (EGL) is the line showing the total energy of the flow above some arbitrary horizontal datum. The slope of the EGL is called the energy slope or the friction slope and is designated  $S_f$ . The vertical difference between the HGL and the EGL is the velocity head.

For open (non-pressure) conduit flow:

$$\frac{V_1^2}{2g} + Y_1 + Z_1 = \frac{V_2^2}{2g} + Y_2 + Z_2 + h_f \quad \text{Equation 2}$$

For pressure conduit flow, the Bernoulli Equation is:

$$\frac{V_1^2}{2g} + \frac{P_1}{\gamma} + Z_1 = \frac{V_2^2}{2g} + \frac{P_2}{\gamma} + Z_2 + h_f \quad \text{Equation 3}$$

where the total energy at Section 1 is equal to the energy at Section 2 plus the intervening head loss.

**Figure 1: Terms Used in the Energy Equation**

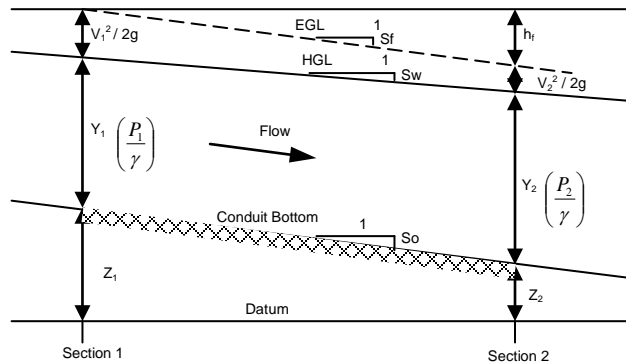

where

EGL = Energy Grade Line

HGL = Hydraulic Grade Line

Y = Water Depth

$\frac{V^2}{2g}$  = Energy Head

V = Mean Velocity

Sf = Slope of EGL

Sw = Slope of HGL

g = acceleration of gravity (32.2 feet per second)

$\frac{P}{\gamma}$  = Pressure Head

P = pressure at given location (lb/ft<sup>2</sup>)

$\gamma$  = specific weight of water (62.4 lb/ft<sup>3</sup>)

Z = elevation relative to some datum

So = Slope of Bottom

hf = Head Loss

### 3. Manning Equation

The Manning Equation is widely used in open channel flow, but may also be applied to closed conduit and pressure flows.

For a given channel geometry, slope and roughness, and a specified value of discharge Q, a unique value of depth (normal depth) occurs in a steady uniform flow.

The Manning Equation as written in USCS units is

$$V = \frac{Q}{A} = \frac{1.486}{n} r^{2/3} s^{1/2} \tag{Equation 4}$$

where

V = Average of Mean Velocity (feet per second)

Q = Discharge, cubic feet per second

A = Cross-sectional flow area (ft<sup>2</sup>)

n = Roughness coefficient

r = A/P = Hydraulic radius (feet) – Note: for pipes full or near full,  $r = \frac{\text{Depth}}{4}$

p = Wetted perimeter (feet)

s = Slope of the hydraulic grade line (ft/ft)

**Figure 2: Hydraulic Properties Circular Pipe for Partial Flow Depth**

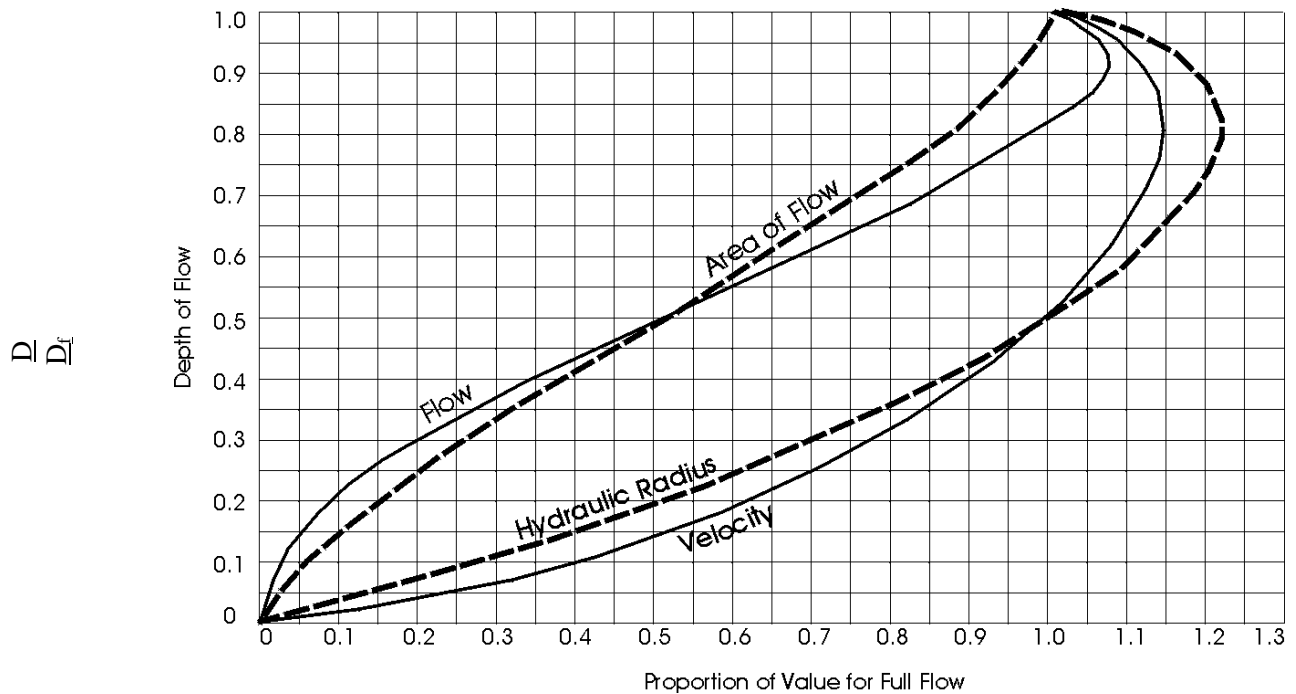

$$\frac{Q}{Q_f}, \frac{A}{A_f}, \frac{R}{R_f}, \frac{V}{V_m}$$

where

D = Diameter of Pipe

D<sub>f</sub> = Depth of Flow

Figure 3: Discharge of Circular Pipe Flowing Full (Based on Manning's Equation  $n = 0.013$ )

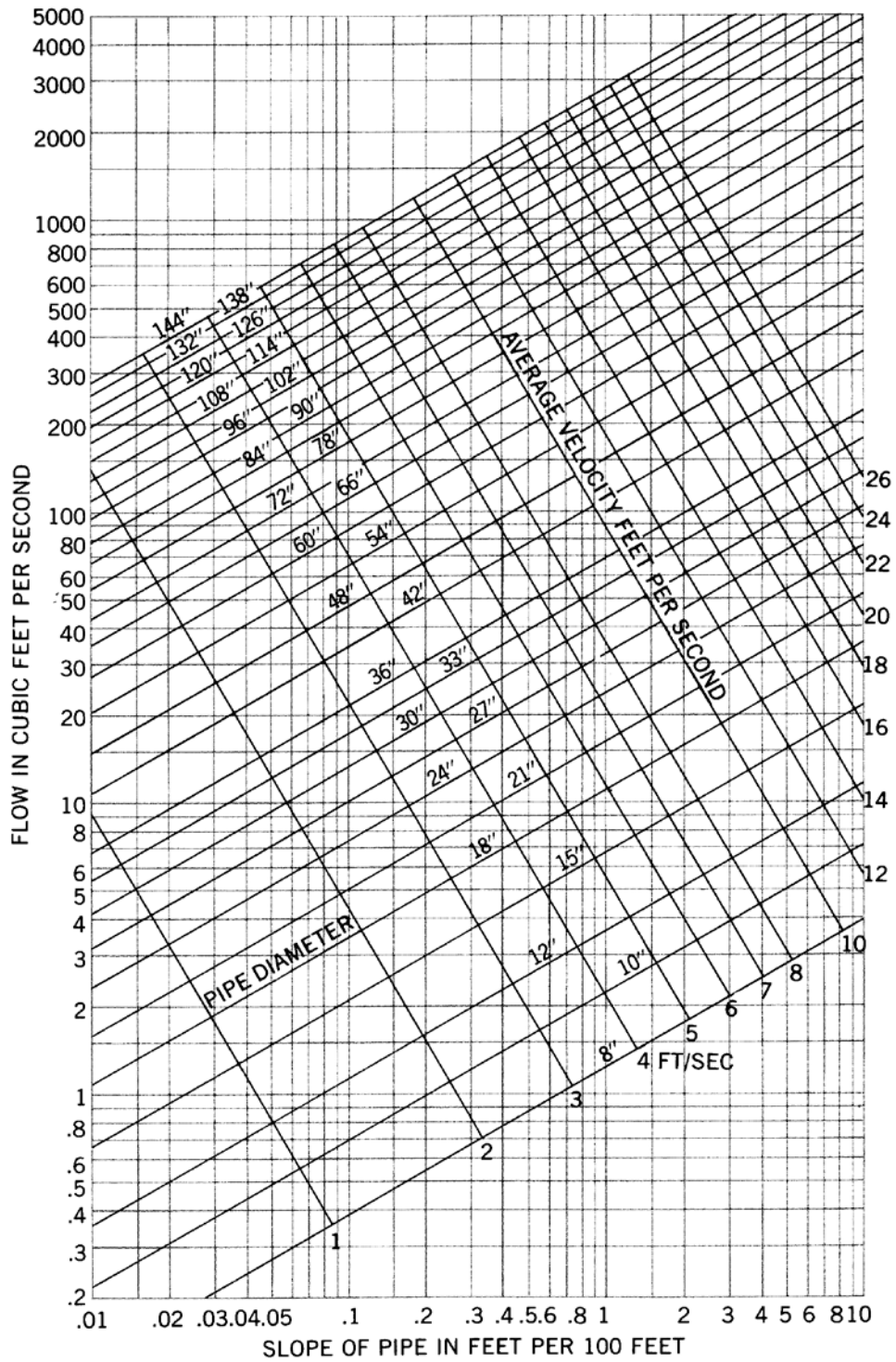

## C. Hydraulic losses

Storm sewers should be designed to convey the minor storm flood peaks without surcharging the sewer. In situations where surcharging is a concern, the hydraulic grade line may be calculated by accounting for pipe friction losses and pipe form losses. Total hydraulic losses will include friction, expansion, contraction, bend, and junction losses. The methods for estimating these losses are presented herein.

1. **Pipe friction losses.** The Manning's "n" values to be used in the calculation of storm sewer capacity and velocity are shown as follows:

Type of Pipe	Manning's "n"
Vitrified clay pipe	0.013
Plastic pipe (smooth wall)	0.010
Concrete pipe	0.013
Corrugated plastic pipe	0.020
CMP (2-2/3" x 1/2" corrugations)	0.024
(spun asphalt lined)	0.015
CMP (3" x 1" corrugations)	0.027
Structural Plate	0.032

2. **Pipe form losses.** Generally, between the inlet and outlet the flow encounters a variety of configurations in the flow passageway such as changes in pipe size, branches, bends, junctions, expansions, and contractions. These shape variations impose losses in addition to those resulting from pipe friction. Form losses are the result of fully developed turbulence and can be expressed as follows:

$$H_L = K \frac{V^2}{2g} \quad \text{Equation 5}$$

where

$H_L$  = head loss (feet)

$K$  = loss coefficient

$K \frac{V^2}{2g}$  = velocity head (feet)

$g$  = gravitational acceleration (32.2 ft/sec)

The following is a discussion of a few of the common types of form losses encountered in sewer system design.

- a. **Pipe friction losses.** The friction slope is the energy slope in feet per foot for that run. The friction loss is simply the energy gradient multiplied by the length of the run. Energy losses from pipe friction may be determined by rewriting the Manning's equation with terms as previously defined:

$$S_{fo} = 0.453 \frac{Q^2 n^2}{A^2 R^{4/3}} \quad \text{Equation 6}$$

Then the head losses due to friction may be determined by the formula:

$$H_L = S_{fo} L \quad \text{Equation 7}$$

where

$H_f$  = Fiction head loss (feet)

$S_{fo}$  = Friction slope (feet/feet)

$L$  = Length of outflow pipe (feet)

- b. **Expansion losses.** Expansion in a storm sewer conduit will result in a shearing action between the incoming high velocity jet and the surrounding sewer boundary. As a result, much of the kinetic energy is dissipated by eddy currents and turbulence. The loss of head can be expressed as:

$$H_L = K_e \frac{V_1^2}{2g} \left[ 1 - \left( \frac{A_1}{A_2} \right) \right]^2 \quad \text{Equation 8}$$

in which  $A$  is the cross section area,  $V$  is the average flow velocity, and  $K$  is the loss coefficient. Subscripts 1 and 2 denote the upstream and downstream sections, respectively. The value of  $K_e$  is about 1.0 for a sudden expansion, and about 0.2 for a well-designed expansion transition. Table 1 presents the expansion loss coefficients for various flow conditions.

- c. **Contraction losses.** The form loss due to contraction is:

$$H_L = K_c \frac{V_1^2}{2g} \left[ 1 - \left( \frac{A_2}{A_1} \right) \right]^2 \quad \text{Equation 9}$$

where  $K_c$  is the contraction coefficient.  $K_c$  is equal to 0.5 for a sudden contraction and about 0.1 for a well designed transition. Subscripts 1 and 2 denote the upstream and downstream sections, respectively. Table 1 presents the contraction loss coefficient for various flow conditions.

- d. **Bend losses.** The head losses for bends, in excess of that caused by an equivalent length of straight pipe, may be expressed by the relation:

$$H_L = K_b \frac{V^2}{2g} \quad \text{Equation 10}$$

in which  $K_b$  is the bend coefficient. The bend coefficient has been found to be a function of:

- 1) the ratio of the radius of curvature of the bend to the width of the conduit
- 2) deflection angle of the conduit
- 3) geometry of the cross section of flow
- 4) the Reynolds number and relative roughness.

Table 2 shows the recommended bend loss coefficients.

- e. **Junction and manhole losses.** A junction occurs where one or more branch sewers enter a main sewer, usually at manholes or intakes. The hydraulic design of a junction is in effect the design of two or more transitions, one for each flow path. Allowances should be made for head loss due to the impact at junctions. See Table 3 for  $K_j$  values. The head loss for a straight through manhole or at an inlet entering the sewer is calculated from Equation 1. The head loss at a junction can be calculated from:

$$H_L = \frac{V_2^2}{2g} - K_j \frac{V_1^2}{2g} \quad \text{Equation 11}$$

where  $V_2$  is the outfall flow velocity and  $V_1$  is the inlet velocity.

3. **Junction drop.** When there is an increase in sewer size of a smaller sewer connected with a larger one, the invert of the smaller sewer must be raised to maintain the same energy gradient. An approximate method of doing this is to place the 0.8 depth point of both sewers at the same elevation. When there is a change in alignment between storm sewer of  $45^\circ$  or greater the suggested minimum manhole drop is 0.10 foot.
4. **Storm sewer outlets.** When the storm sewer system discharges into the Major Drainageway System (usually an open channel), additional losses occur at the outlet in the form of expansion losses. For a headwall and no wingwalls, the loss coefficient  $K_c = 1.0$  (refer to Table 6), and for a flared-end section the loss coefficient is approximately 0.5 or less.

**Table 1:** Storm Sewer Energy Loss Coefficient (Expansion, Contraction)

(a) Expansion ( $K_e$ )

$\theta^*$	$K_e$	
	$\frac{D_2}{D_1} = 3$	$\frac{D_2}{D_1} = 1.5$
10	0.17	0.17
20	0.40	0.40
45	0.86	1.06
60	1.02	1.21
90	1.06	1.14
120	1.04	1.07
180	1.00	1.00

\* The angle  $\theta$  is the angle in degrees between the sides of the tapering section.

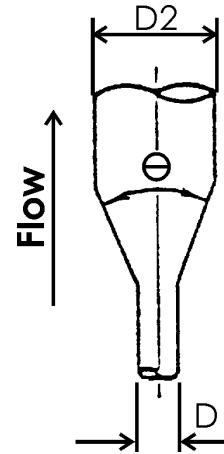

Expansion

(b)  $K_e$  for Pipe Entrance from Reservoir

Pipe Entrance Shape	$K_e$
Bell-mouth	0.1
Square-edge	0.5
Concrete Pipe Groove End	0.2

(c) Contractions ( $K_c$ )

$\frac{D_2}{D_1}$	$K_c$
0	0.5
0.4	0.4
0.6	0.3
0.8	0.1
1.0	0

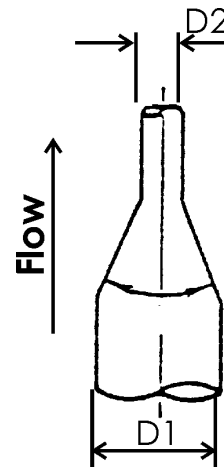

Contraction

**Table 2:** Storm Sewer Energy Loss Coefficient (Bends)

$$K_6 = \left( 0.13 + 1.85 \left( \frac{r}{R} \right)^{3.5} \right) \sqrt{\frac{\theta^\circ}{180^\circ}}$$

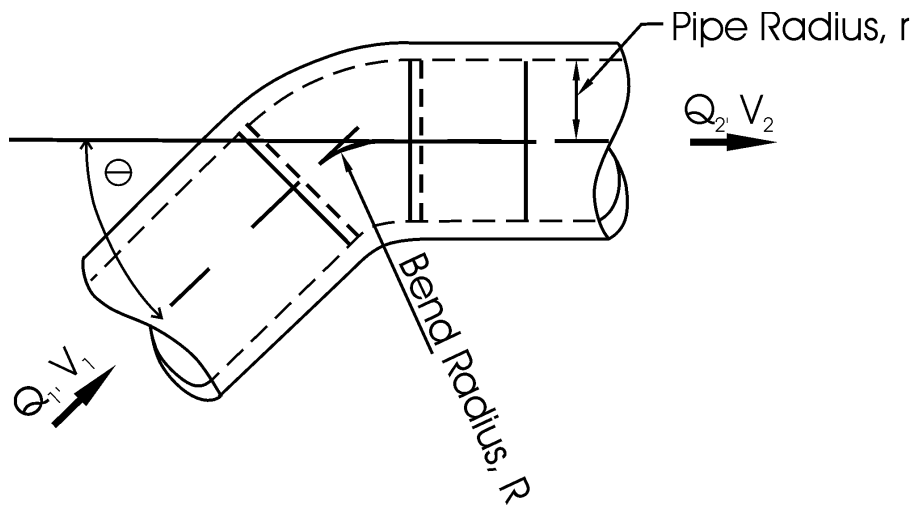

**Table 3: Manhole and Junction Losses**

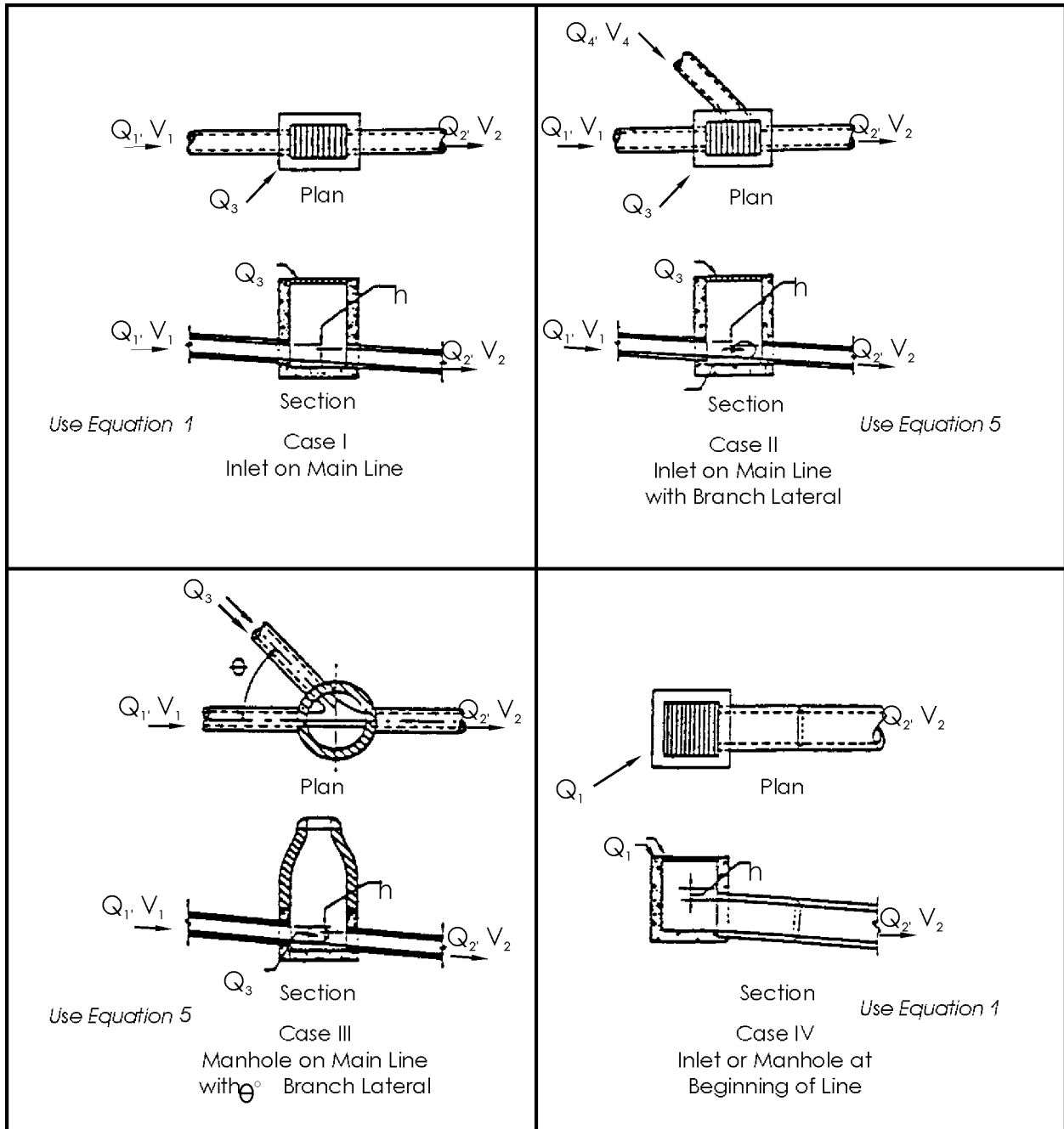

Case		$K_i$
I		0.05
II		0.25
III	$\theta = 22.5^\circ$	0.75
	$\theta = 45^\circ$	0.50
	$\theta = 60^\circ$	0.35
	$\theta = 90^\circ$	0.25
IV		1.25

## D. Hydraulic design of storm sewers

The following calculation example was obtained from Modern Sewer Design, AISI Wash., D.C., 1980 and edited for the calculation of manhole and junction losses according to this section.

### 1. Given:

- a. Plan and Profile of storm sewer (Figures 4 and 5).
- b. Station 0+00 (outfall) data as follows:

			<u>COL. #</u>
Design discharge	Q	= 145 cfs	[9]
Invert of pipe		= 94.50'	[2]
Starting water surface	W.S.	= 100'	[4]

Note: Number in brackets refers to the columns of Table 1.

The pipe diameter needs to meet: 1) Low-flow cleaning velocity, 2) Slope for full flow, and 3) Surcharges in manhole or intake structures.

### 2. Find: Pipe size to meet low-flow: Use 3 fps for cleaning velocity

STEP 1: Q mean annual storm = 10 cfs  
 $Q_{MA}/Q_{10} = 0.07$  ratio of cleaning discharge to design discharge

STEP 2: Go to Figure 5 and using a 0.07 ratio on the horizontal axis and flow curve, the depth of flow in the pipe will equal 0.16 for cleaning velocity.

STEP 3: Using 0.16 for depth of flow on the vertical axis of Figure 5, and the ratio of  $\frac{V_{CleaningVelocity}}{V_{FullFlow}}$  is 0.53.

STEP 4:  $V_{ff} = \frac{3 \text{ fps}}{0.53} = 5.66$ , or 6 fps

STEP 5: Area of Pipe =  $\frac{145 \text{ cfs}}{6 \text{ fps}} = 24.2$  sq. ft.

$$R = \left( \frac{24.2}{3.14} \right)^{1/2} = 2.78 \text{ ft} = 5.55 \text{ ft}$$

Dia. = 5.5 ft or 66 in

### 3. Find: Slope of Pipe

STEP 1:  $Q_{10} = 145$  cfs, Velocity  $\approx 6$  fps, and Pipe = 66 in

STEP 2: Using Manning's Equation (Figure 4) for  $n = 0.13$ , the slope is 0.175 ft/ft

4. **Find:** Hydraulic Grade Line and Energy Grade Line for storm sewer.  
The following procedure is based on full-flow pipe conditions. If the pipe is flowing substantially full (i.e., greater than 80%), the following procedures can be used with minimal loss of accuracy. However, the designer is responsible for checking the assumptions (i.e., check for full flow) to assure that the calculations are correct.

STEP 1: The normal depth is greater than critical depth,  $d_n > d_c$ ; therefore, calculations to begin at outfall, working upstream. Compute the following parameters:

$$\text{Constant value [7]:} = \frac{2gn^2}{2.21} = \frac{(2)(32.2)(0.013)^2}{2.21}$$

This equation is derived from the Manning's equation by solving for velocity and converting to velocity head.

$$= 0.00492$$

This value remains constant for this design since the n-value does not change.

STEP 2: Velocity head [10]:  $H_v = \frac{V^2}{2g} = \frac{(6.1)^2}{(2)(32.2)}$

$$H_v = 0.58$$

STEP 3: Energy Grade Point, E.G. [11]:  $E.G. = W.S. + H_v = 100 + 0.58$

$$E.G. = 100.58$$

For the initial calculation, the Energy Grade Line is computed as described above. For subsequent calculations, the equation is reversed, and the water surface is calculated as follows (see Step 12):

$$W.S. = E.G. - H_v$$

This equation is used since the losses computed in Step 8 are energy losses which are added to the downstream energy grade elevation as the new starting point from which the velocity head is subtracted as shown above.

STEP 4: Skin Friction:

$$S_f \text{ value [12]: } S_f = \phi \frac{H_v}{R^{4/3}} = \frac{(0.00492)(0.58)}{(1.375)^{4/3}}$$

NOTE: R = the hydraulic radius of the pipe.

$$\phi = \frac{2gn^2}{2.21}$$

$$S_f = 0.0019$$

STEP 5: Avg.  $S_f$  [13]: Average skin friction: This is the average value between  $S_f$  of the station being calculated and the previous station. For the first Station, Avg.  $S_f = S_f$ .

Beginning with Column [13], the entries are placed in the next row since they represent the calculated losses between two stations.

STEP 6: Enter sewer length, L, in column [14].

STEP 7: Friction loss  $H_f$  [15]:

$$H_f = (\text{Avg. } S_f)(L)$$

$$H_f = \frac{0.0019}{110}$$

$$H_f = 0.21$$

STEP 8: Calculate the form losses for bends, junctions, manholes, and transition losses (expansion or contraction) using equations 1, 2, 3, 4, and 5. The calculation of these losses is presented below for the various sewer segments, since all the losses do not occur for one sewer segment.

(a) Station 1 + 10 to 1 + 52.4 (bend)

$$H_L = K_b H_v, \text{ where the degree of bend is } 60^\circ.$$

$$K_b = 0.20 \text{ (Table 3, Case I)}$$

$$H_L = \frac{0.20}{0.58} = 0.12, \text{ enter in column 16.}$$

(b) Station 2 + 48 to 2 + 55.5 (transition: expansion)

$$H_L = K_e H_v \left[ 1 - \left( \frac{A_1}{A_2} \right) \right]^2$$

$$K_e = 1.06 \text{ (Table 1) for } D_2/D_1 = 1.5, \text{ and } = 45^\circ.$$

$$H_L = (1.06)(1.29) \left[ 1 - \left( \frac{15.9}{23.76} \right) \right]^2 = 0.15, \text{ enter in column 19.}$$

- (c) Station 3 + 55.5 (manholes, straight through)

$$H_L = K_m H_v$$

$$K_m = 0.05 \text{ (Table 3, Case I)}$$

$$H_L = \frac{0.05}{1.29} = 0.06, \text{ enter in column 18.}$$

- (d) Station 4 + 55.5 to 4 + 65.5 (junction)

$$H_L = \frac{V_2^2}{2g} - K_j \frac{V_1^2}{2g}$$

$$K_j = 0.62 \text{ (Table 3, Case III), } \theta = 30^\circ, V_1=0.99, V_2=1.29$$

$$H_L = 1.29 - \frac{0.62}{0.99} = 0.68, \text{ enter in column 17}$$

- (e) Station 5 + 65.5 to 5 + 75.5 (junction) - since there are two laterals, the loss is estimated as twice the loss for one lateral

$$K_j = 0.33 \text{ (Table 3, Case III), } \theta = 70^\circ$$

$$H_L = 0.99 - \frac{0.33}{0.64} = 0.78 \text{ for one lateral, 1.56 for 2 laterals}$$

STEP 9: Sum all the form losses from columns [15] through [19] and enter in column [20]. For the reach between Station 0+00 to 1+10, the total loss is 0.21.

STEP 10: Add the total loss in column [20] to the energy grade at the downstream end (Sta. 0+00) to compute the energy grade at the upstream end (Sta. 1+10) for this example).

$$\text{E.G. (Upstream)} = \text{E.G. (Downstream)} + \text{TOTAL LOSS}$$

$$= 100.58 + 0.21$$

$$= 100.79 \text{ (Column 11)}$$

STEP 11: Enter the new invert [2], pipe diameter D[3], pipe shape [5], pipe area A, [6], the computed constant from Step 1 in column [7], the computed velocity V in column [8], the new Q [9], and the computed velocity head  $H_v$  [10].

STEP 12: Compute the new water surface, W.S., for the upstream Station (1+10 for this example).

$$\begin{aligned} \text{W.S.} &= \text{E.G.} - H_v \\ &= 100.79 - 0.58 \\ &= 100.21 \text{ (column 4)} \end{aligned}$$

STEP 13: Repeat Steps 1 through 12 until the design is complete. The hydraulic grade line and the energy grade line are plotted on the profile (Figure 2).

5. **Discussion of results:** The Hydraulic Grade Line (HGL) is at the crown of the pipe from Station 0+00 to 2+48. Upstream of the transition (Station 2+55.5) the 54-inch RCP has a greater capacity (approximately 175 cfs) at the slope than the design flow (145 cfs). The pipe is therefore not flowing full but is substantially full (i.e.,  $145/175 = 0.84$  greater than 0.80). The computed HGL is below the crown of the pipe. However, at the outlet, the actual HGL is higher, since the outlet of the 54-inch RCP is submerged by the headwater for the 66-inch RCP. To compute the actual profile, a backwater calculation would be required; however, this accuracy is not necessary for storm sewer design in most cases.

At the junction (Station 4+55.5), the HGL is above the top of the pipe due to the losses in the junction. In this case, however, the full flow capacity (100 cfs) is the same as the design capacity, and the HGL remains above and parallel to the top of the pipe. A similar situation occurs at the junction at Station 5+65.5.

If the pipe entering a manhole or junction is at an elevation significantly above the manhole invert, a discontinuity in the Energy Grade Line (EGL) may occur. If the EGL of the incoming pipe for the design flow condition is higher than the EGL in the manhole, then a discontinuity exists, and the higher EGL is used for the incoming pipe.

Figure 4: Design Example for Storm Sewers - Plan

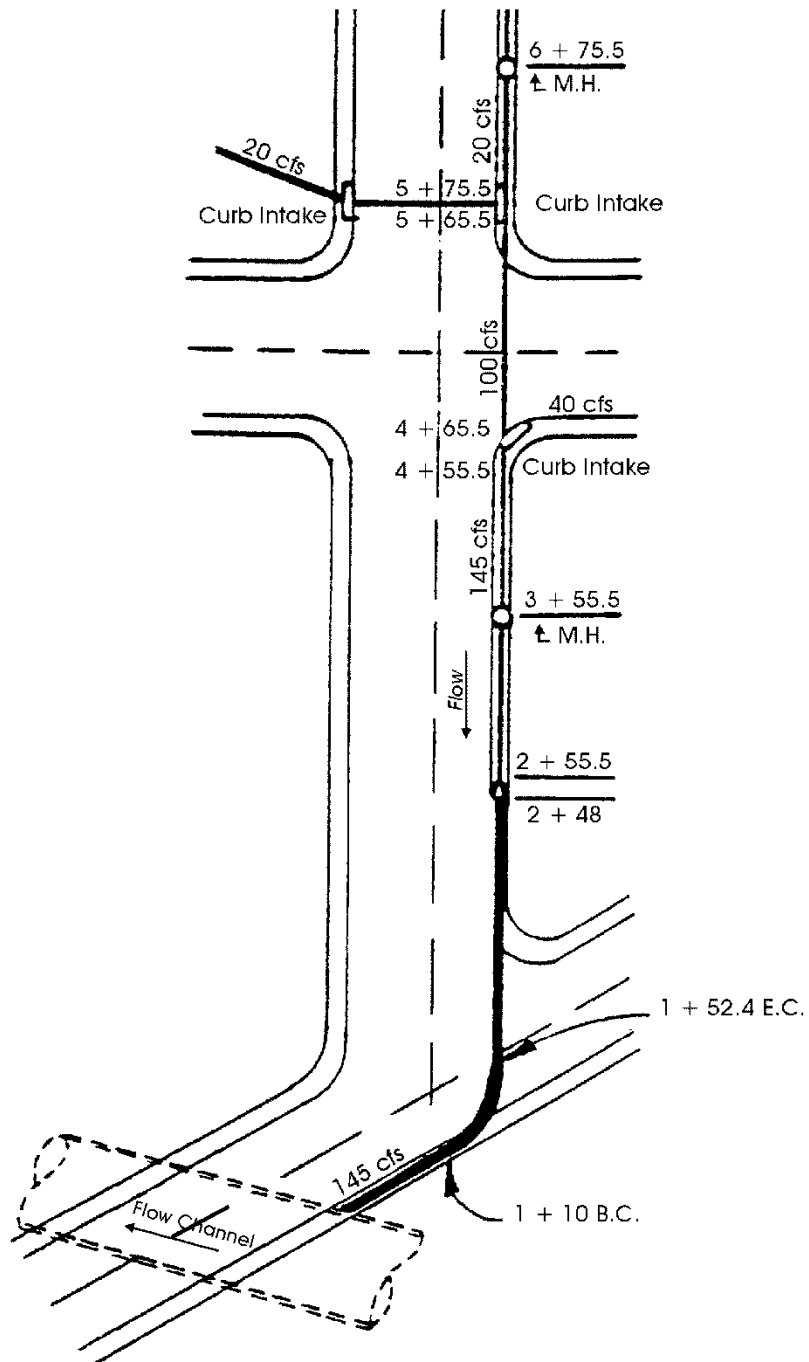

Figure 5: Design Example for Storm Sewers - Profile

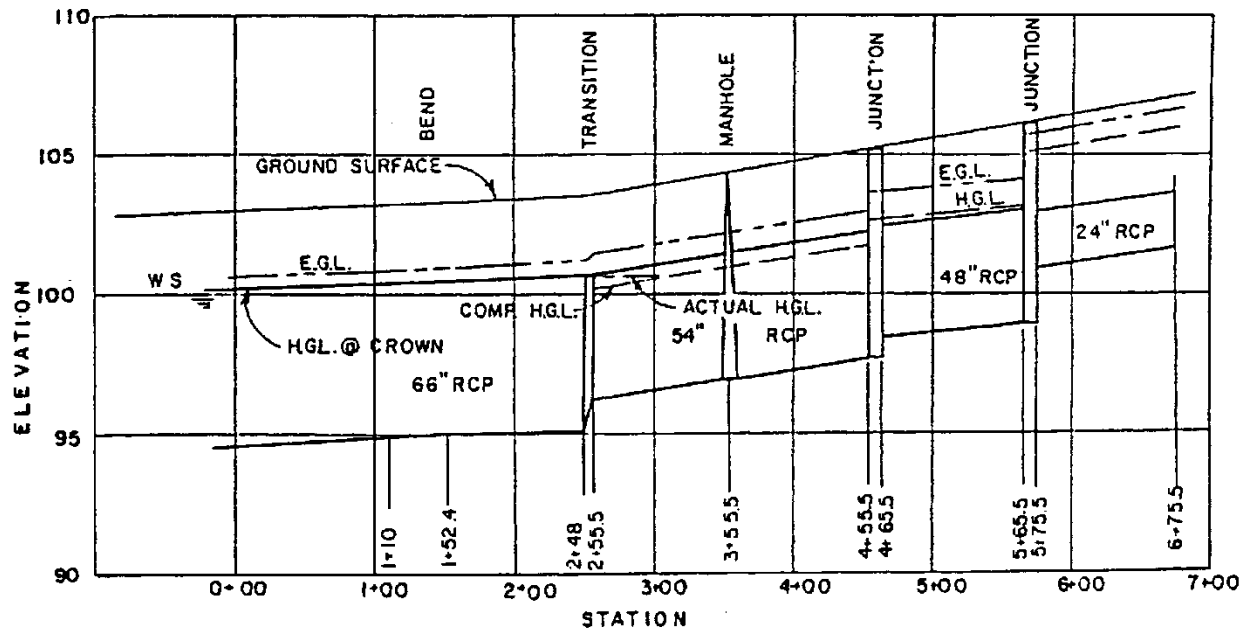

Table 4: Design Example for Storm Sewers

1	2	3	4	5	6	7	8	9	10	11	12	13	14	15	16	17	18	19	20
STA	INVERT	D	W.S.	PIPE SHAPE	A	φ	V	Q	Hv	E.G.	Sf	AVG. Sf	L	Hf	Hb	Hj	Hm	Ht	TOTAL LOSS
0+00	94.50	66	100.00	RND	23.76	0.00492	6.1	145	0.58	100.58	0.0019	0.0019	110	0.21	--	--	--	--	0.21
1+00	94.71	66	100.21	RND	23.76	0.00492	6.1	145	0.58	100.79	0.0019	0.0019	42.4	0.08	0.12	--	--	--	0.2
1+52.4	94.91	66	100.41	RND	23.76	0.00492	6.1	145	0.58	100.99	0.0019	0.0019	95.6	0.18	--	--	--	--	0.18
2+48	95.08	66	100.59	RND	23.76	0.00492	6.1	145	0.58	101.17	0.0019	0.0048	7.5	0.04	--	--	--	0.15	0.19
2+55.5	96.08	54	100.07	RND	15.90	0.00492	9.1	145	1.29	101.36	0.0076	0.0076	100	0.76	--	--	0.06	--	0.82
3+55.5	96.90	54	100.89	RND	15.90	0.00492	9.1	145	1.29	102.18	0.0076	0.0076	100	0.76	--	--	--	--	0.76
4+55.5	97.66	54	101.65	RND	15.90	0.00492	9.1	145	1.29	102.94	0.0076	0.0063	10	0.06	--	0.68	--	--	0.74
4+65.5	98.40	48	102.69	RND	12.57	0.00492	8.0	100	0.99	103.68	0.0049	0.0049	100	0.49	--	--	--	--	0.49
5+65.5	98.89	48	103.18	RND	12.57	0.00492	8.0	100	0.99	104.17	0.0049	0.0064	10	0.06	--	1.56	--	--	1.62
5+75.5	100.89	24	105.15	RND	3.14	0.00492	6.4	20	0.64	105.79	0.0079	0.0079	100	0.79	--	--	0.03	--	0.82
6+75.5	101.61	24	105.79	RND	3.14	0.00492	6.4	20	0.64	106.61	0.0079								

$$Sf = \frac{\phi Hv}{R^{1.33}}$$

TOTAL FRICTION LOSS = 3.43

$$\phi = \frac{2g(n^2)}{2.21}$$

TOTAL FORM LOSS = 2.75