

## 5G-2 Types of Joints

Joints shall conform to the details indicated on the plans and specifications of each Jurisdiction. In order for all joints to perform their required function, they must be constructed to comply with their intended design. Standard design considerations include the following: type of subbase used, adequate and properly installed load transfer units and the selection and application of the sealant material. Effective sealing is an important requirement to assure the continuing function of concrete pavement joints. Water percolation and infiltration can prevent the best joint design from functioning properly. For details of joints, see Figures 6 through 10.

**Table 1:** Maximum joint spacing for plain jointed pavement transverse and longitudinal joints

| Pavement Thickness (T) | Maximum Transverse 'C' Joints | Maximum Transverse 'CD' Joints | Maximum Longitudinal Joint Spacing |
|------------------------|-------------------------------|--------------------------------|------------------------------------|
| < 9"                   | 15'                           | 15'                            | 12-1/2'                            |
| 9"                     | 15'                           | 15'                            | 14-1/2'                            |
| > 9"                   | 15'                           | 20'                            | 14-1/2'*                           |
| *16' for Ramps         |                               |                                |                                    |

### A. Transverse contraction joints

Contraction joints constructed transversely (right angles) across pavement lanes are spaced to control cracking of the concrete pavement as a result of stresses caused by volume change due to moisture loss and thermal change during the curing process.

1. **Plain contraction joints.** Plain contraction joints are normally used in local streets and minor collectors where load transfer is not a major factor. Load transfer for plain contraction joints occurs through the adjacent irregular fractured faces. Generally, they are used when the slab thickness is less than 8 inches. The joints are constructed by sawing to a depth of T/3 and are spaced at 15-foot intervals. Plain contraction joints are sometimes used when the pavement thickness is 9 inches or greater such as at intersections in boxouts near curbs where load transfer is not a concern. Approved early concrete sawing equipment may be used to cut the joint to a depth of 1-1/4 inch. Before sealing, the joint width must be a minimum of 1/4 inch wide.

**Figure 1:** 'C' plain contraction joint

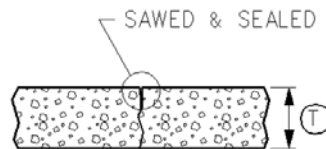

- Doweled contraction joints.** Dowel bars are used to supplement the load transfer produced by aggregate interlock and stabilized subbases. The joints are sawed to a depth of  $T/3$  and are spaced at 15-foot intervals for slab thickness of 9 inches or less and 20 feet for slabs greater than 9 inches thick. The dowels are placed at the mid-depth in the slab so they can resist shear forces as dynamic loads cross the joint; thus helping reduce deflection and stress of the joint. The need for doweled contraction joints depends on subgrade conditions and the service the roadway is to provide. They are used on streets or roadways where the pavement thickness is 8 inches or greater and where the pavement is subject to heavier truck traffic, generally more than 80 semi-trailer trucks per lane per day. Early entry concrete sawing can be used for 'CD' joints.

**Figure 2:** 'CD' doweled contraction joint

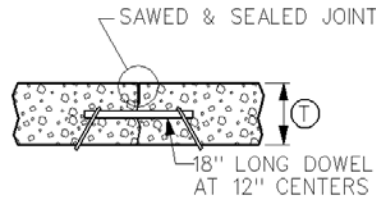

## B. Longitudinal contraction joints

Longitudinal contraction joints release stresses from restrained warping and dynamic loading. Under certain conditions, such as rapidly dropping air temperature during the night, longitudinal cracks may occur early. Therefore, early formation of the joint is required. The jointing discussed in this section relates to full width paving.

Typically, sawed longitudinal joints are sealed. However, since the slabs on either side of the longitudinal contraction joint are tied by a reinforcing bar, the Jurisdictional Engineer may approve not sealing the joint. The need to seal the joint is reduced due to the tied connection and the fact the joint will not open. The depth of cut for sawed longitudinal joints is  $T/3$ , regardless of the method of sawing used. The width of the sealed joints is  $1/4$  inch  $\pm$   $1/16$  inch. The maximum width of the unsealed joints is  $1/8$  inch  $\pm$   $1/16$  inch.

A longitudinal joint is usually placed at the center of the pavement to allow the pavement to hinge due to lane loading and help delineate separation of opposing traffic. Controlling cracking and proper constructability are the primary functions of longitudinal contraction joints. Lane delineation is a secondary function.

Figure 3: Longitudinal contraction joints

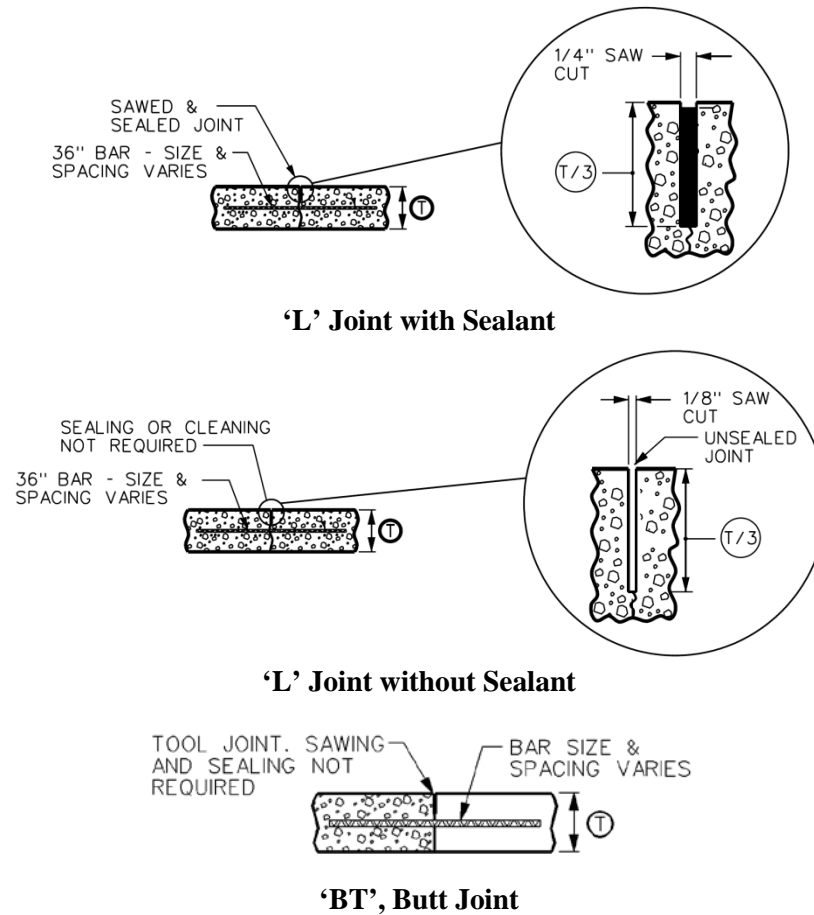

An important consideration when establishing the distance between longitudinal joints for plain jointed pavements is the prevention of random longitudinal cracking at the quarter point, the midpoint between the centerline, and the back of the curb. Pavements less than 9 inches thick may not crack through a longitudinal joint placed close to the gutter, which could cause longitudinal cracks at the quarter point. For this reason, it is preferred to use quarter-point jointing for 31-foot wide pavements. Third point jointing, which eliminates the centerline joint, is frequently used for pavement narrower than 30 feet because of the narrower panel width and for 31-foot wide pavements with a depth greater than 8 inches. However, some jurisdictions desire a centerline joint and a gutterline joint, typically 3 to 3-1/2 feet from the back of curb. A gutterline joint should only be used if the pavement has depth exceeding 8 inches or pavement widening is likely to occur.

The following examples depict jointing options for 26-foot and 31-foot wide pavements. The principles involved with jointing for these pavement widths can be extended to other pavement widths.

1. **26-foot B-B pavement.** Three longitudinal joint options for plain jointed 26-foot wide pavements are provided:

Third point jointing, provides for a single 9-foot center panel with two joints, each 8-1/2 feet from the back of curb.

Quarter point jointing, includes a centerline joint and two joints at the quarter points and where centerline crack control is desired.

Gutterline jointing provides two 10-foot lanes with a centerline joint and also gutterline joints 3 feet from the back of curb. As stated above, care must be exercised with this option to prevent random cracking at the quarter point. This option is typically used for streets 9 inches or greater in thickness.

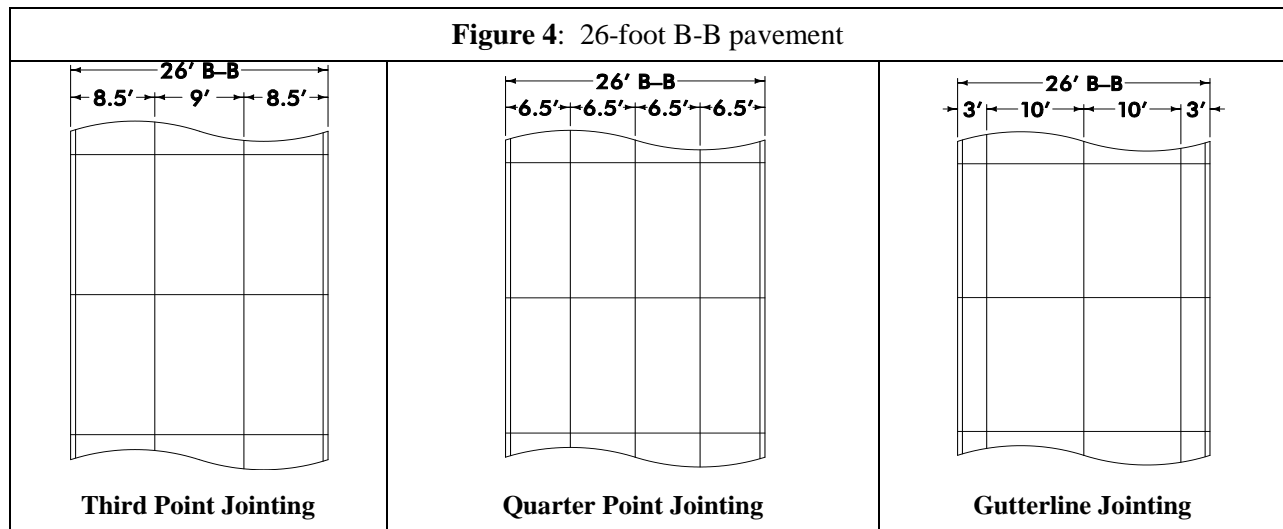

2. **31-foot B-B pavements.** Three longitudinal joint options for 31-foot wide pavements are provided.

Quarter point jointing does not delineate driving lanes but provides for a centerline longitudinal joint and two quarter point joints.

Third point jointing provides three nearly equally spaced panels, without a centerline joint. It typically is used as an option to quarter point jointing to minimize the number of longitudinal joints.

Gutterline jointing is to delineate the standard driving lanes with a centerline joint and gutterline joints 3 to 3-1/2 feet from the back of curb. This jointing pattern is typically used when the pavement may be widened in the future, and the delineation of the lanes is desired. Care must be exercised with this option to prevent random cracking at the quarter point. This pattern is typically used on streets with pavement thickness greater than or equal to 9 inches.

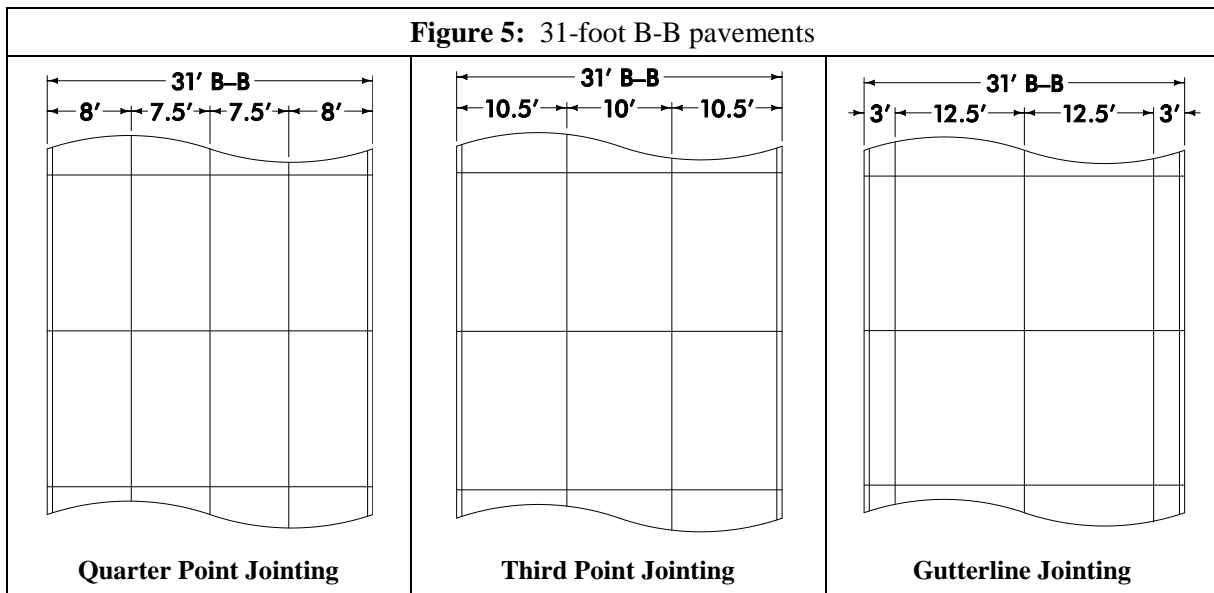

### C. Transverse and longitudinal construction joints

Construction joints are necessary for planned construction interruptions or widening/extending a pavement. Examples are when an adjacent lane is constructed at a different time; box-outs for structures, radii, etc are required; paving operations stop for over 30 minutes; or when a joint is needed between dissimilar materials. Construction joints are also used between an existing pavement and a new pavement. The joint is formed with the existing slab and is not sawed, except to accommodate joint sealing. Sawing and sealing of the joints are not required for those tied with deformed bars.

1. **Transverse construction joints.** These types of joints are usually butt-type joints with deformed tie bars or dowels to provide load transfer and prevent vertical movement. When joint sealing is required, the depth of the saw cut (1-1/4 inches) is just deep enough to provide a reservoir for the joint sealing. The following are typical transverse construction joints.

**Figure 6: Transverse construction joints**

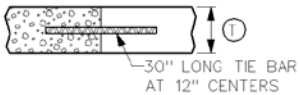
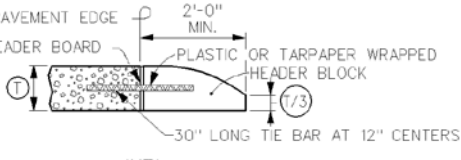
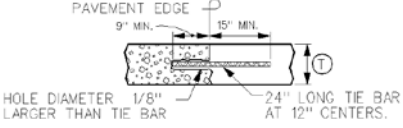
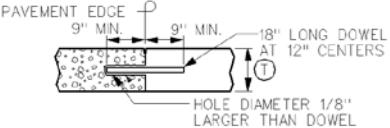
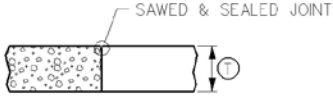
|  |  |
|--|--|
|  <p>'DW'<br/>DAY'S WORK JOINT (NON-WORKING)</p>               | <p>Used by contractors at emergency (unplanned) stopping point. Ideally, it should be located at mid-panel, but it should not be located less than 5 feet from a planned contractor joint.</p> |
|  <p>'HT'<br/>HEADER JOINT<br/>(END RIGID PAVEMENT)</p>        | <p>Used when the pavement ends and traffic will cross the joint. The header is removed when the pavement is extended.</p>  |
|  <p>'RT'<br/>ABUTTING PAVEMENT JOINT<br/>RIGID TIE</p>        | <p>Typically used when an older slab is extended. Also may be used as a tied contraction joint.</p>  |
|  <p>'RD'<br/>ABUTTING PAVEMENT JOINT</p>                     | <p>Used when dowel bars are used (CD joints) and the existing slab is to be extended. Normally used when the pavement is 8 inches or greater.</p>  |
|  <p>'B'<br/>PLAIN JOINT<br/>FOR ABUTTING PAVEMENT SLABS</p> | <p>Typically is used when abutting two different pavement types or thicknesses or adjacent to the face of storm sewer intakes.</p>   |

2. **Longitudinal construction joint.** These types of joints are used when lanes are constructed at different times. Tie-bars help with load transfer and vertical control, but are mainly designed to resist horizontal movement. Under certain conditions, such as a drop in air temperature during the first night, longitudinal and transverse cracks may occur early. Early construction sawing of transverse joints is important when tied longitudinal construction joints are constructed in order to prevent the following two conditions from occurring.
  - a. **Sympathy transverse cracking in new lane construction.** When the new slab is longitudinally tied to an existing pavement, the existing transverse contraction joints can cause adjacent lane cracking in the new slab if early sawing of the transverse joints is not done. If existing transverse random cracks exist in an older slab, the longitudinal construction joint may need to be a plain butt joint or keyed joint, if one exists in the old slab, with no tie-bars to prevent sympathy cracks in the new pavement.

- b. **Longitudinal tie-bar stress in cooler weather conditions.** Care must be exercised to control cracking when utilizing longitudinal construction joints with tie bars, particularly in cool temperatures. For example, when a lane is constructed one day and the adjacent lane is constructed the following day or later, the existing lane could be expanding, particularly in the morning. If the new lane is in its final set (contracting) at the same time the existing pavement is expanding, stresses in the concrete at the tie bars can be significant. If the strength of the new concrete has not developed enough to resist the stresses, cracking could occur in the new concrete at the tie bars. Under cooler weather conditions, care should be exercised when paving the new lane. Ideally, the new paving operation should take place at mid-day or later when the existing lane expansion is reduced.

| <b>Figure 7: Longitudinal construction joints</b> |   |
|---|---|
|   | <p>Used to tie existing and new parallel pavements together to prevent horizontal movements. Will also provide some load transfer and resist vertical movement.</p>   |
|   | <p>Used when tie-bars are not needed and load transfer is required.</p>   |
|   | <p>Used in pavements under heavier traffic conditions and typically where the pavement thickness is 8 inches or greater. Also used at intersections under heavy turning movements where the pavement is less than 8 inches.</p> |

## D. Transverse expansion joints and isolation joints

Expansion and isolation joints accommodate anticipated differential horizontal and vertical movements that occur between a pavement and structure. Their purpose is to allow movement without damaging adjacent structures or pavements. Contraction or control joints also absorb some movement; however, their main function is to control the location and geometry of the natural cracking pattern in the concrete slab. Because pavement performance can be significantly affected by the planned use and location of isolation and expansion joints, care should be taken in their design. Though the terms are sometimes used interchangeably, isolation joints are not expansion joints.

**Transverse expansion joints.** Expansion joints are full-depth, full-width joints. The proper use of expansion joints is to relieve compressive forces caused by movement in the pavement. However, the practice of using evenly spaced contraction joints has, for the most part, eliminated the need for expansion joints. In addition, expansion joints allow too much opening of adjacent transverse joints. The use of transverse expansion joints is an old practice that often caused joint pumping and spalling. Transverse expansion joints are not always needed and often create problems. Transverse expansion joints are needed at certain special locations, such as bridges, which are fixed structures and not subject to the same movements as PCC pavement. It should be noted that adjacent transverse contraction joints may open more than other contraction joints. Therefore, with pavements less than 8 inches, it may be necessary to dowel the first two joints adjacent to the expansion joint to preserve load transfer.

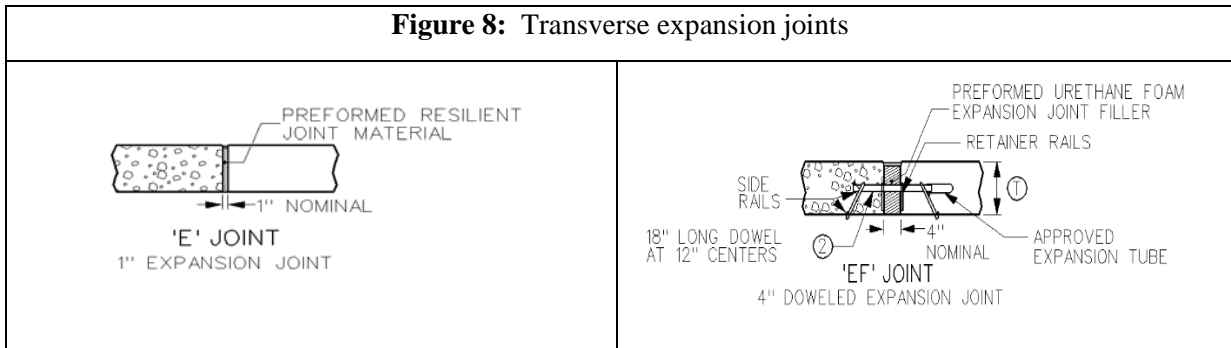

**Isolation joints.** Isolation joints isolate the pavement from a structure, another paved area, or an immovable object. Isolation joints include full-depth, full-width joints found at bridge abutments, intersections, or between old and new pavements. The term “isolation joint” also applies to joints around in-pavement structures such as drainage inlets, manholes, footings, and lighting structures. Isolation joints lessen compressive stresses that develop at T and unsymmetrical intersections, ramps, bridges, building foundations, drainage inlets, manholes, and anywhere differential movement between the pavement and a structure may take place. They are also placed adjacent to existing pavements, especially when it is not possible or desirable to match joint locations in the older pavement. Isolation joints should be 1/2 to 1 inch wide. Greater widths may cause excessive movement. They are filled with a pre-formed joint filler material to prevent infiltration of incompressibles.

At intersections, isolation joints should be used to isolate the intersecting streets from the through street. Also, all legs of skewed streets should be isolated from the through street. Isolation joints used for this purpose should be placed one joint spacing back from the end of the intersection radii.

The joint filler material for expansion and isolation joints occupies the gap between the slabs and must be continuous from one pavement edge to the other and through curb and gutter sections. This filler material is usually a non-absorbent, non-reactive, non-extruding material typically made from either a closed-cell foam rubber or a bitumen-treated fiber board. No plug or sliver of concrete should extend over, under, through, around, or between sections of the filler, or it will cause spalling of the concrete. After the concrete hardens, the top of the filler may be recessed about 3/4 inch below the surface of the slab to allow space for the joint sealant to be placed later.

1. **Doweled isolation joints.** Isolation joints used at structures should have dowels to provide load transfer. The end of the dowel must be equipped with a closed-end expansion cap into which the dowel can move as the joint expands and contracts. The cap must be long enough to cover 2 inches of the dowel and have a suitable stop to hold the end of the cap at least the width of the isolation joint plus 1/4 inch away from the end of the dowel bar. The cap must fit the dowel bar tightly and be watertight. The half of the dowel with the capped end must be coated to prevent bonding and allow horizontal movement.

**Figure 9:** 'ED' joint – 1-inch doweled isolation joint

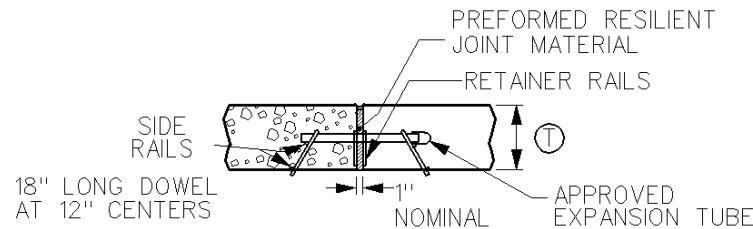

2. **Special undoweled isolation joints.** Isolation joints at T and unsymmetrical intersections or ramps are not doweled so that horizontal movements can occur without damaging the abutting pavement. Undoweled isolation joints can be made with thickened edges to reduce the stresses developed at the slab bottom. The abutting edges of both pavements should be thickened by 20% starting with a taper 5 feet from the joint. The isolation filler material must extend completely through the entire thickened-edge slab.

**Figure 10:** Thickened edge joint

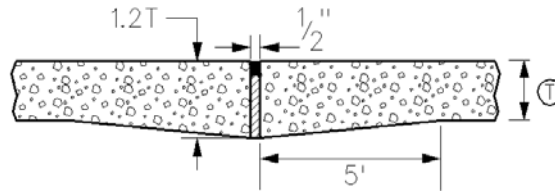

3. **Undoweled isolation joints for box outs.** Isolation joints used at drainage inlets, manholes, and lighting structures do not have thickened edges or dowels.
4. **Adjusting isolation joints for utility fixtures.** After developing the jointing plan, plot any catch basins, manholes or other fixtures that are within the intersection. Non-telescoping manholes will require a boxout or isolation joint to allow for vertical and horizontal slab movement. Consider using rounded boxouts or placing fillets on the corners of square boxouts to avoid crack-inducing corners. Also, for square boxouts, wire mesh or small-diameter reinforcing bars in the concrete around any interior corners will hold cracks tight should they develop. Telescoping manholes can be cast integrally within the concrete, and do not necessarily require a boxout. The multiple piece casting does not inhibit vertical movement and is less likely to create cracks within the pavement.

Finally, when a joint is within 5 feet of a fixture, it is desirable to adjust the joint so that it will pass through the fixture or the boxout surrounding the fixture. The following diagram shows several acceptable ways to skew or shift a joint to meet fixtures.

Figure 11: Typical PCC joint layout at manhole and intakes

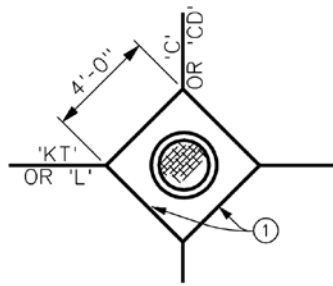

**BOX-OUT DETAIL IN PCC PAVEMENT**  
WHERE THE MANHOLE IS INTERSECTED BY  
THE LONGITUDINAL AND TRANSVERSE JOINTS

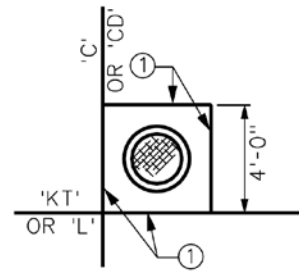

**BOX-OUT DETAIL IN PCC PAVEMENT**  
WHERE THE MANHOLE IS OFFSET FROM THE  
LONGITUDINAL AND TRANSVERSE JOINTS

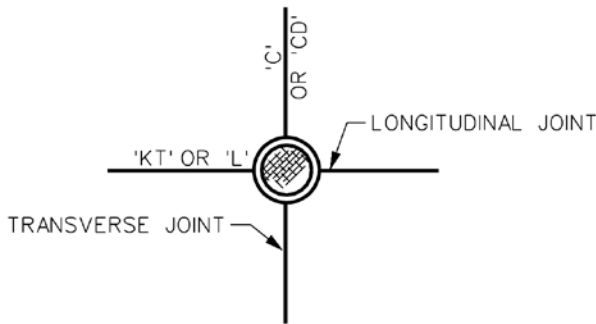

② **NO BOX-OUT IN PCC PAVEMENT**  
FOR TELESCOPING (3 PIECE) MANHOLE ONLY

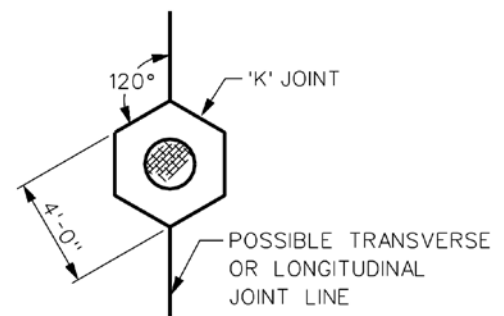

② **BOX-OUT DETAIL IN PCC PAVEMENT**  
WHERE NO JOINT LINES ARE PRESENT  
OR AT A SINGLE JOINT LINE

- ① 'KT' OR 'BT' JOINT IF TELESCOPING (3-PIECE) RING AND COVER (TYPE B, D, & F) IS USED. 'E' JOINT IF NON-TELESCOPING RING AND COVER (TYPE A & C) IS USED.
- ② THE MANHOLE PLACEMENT SHOWN MAY BE USED ONLY UPON APPROVAL OF THE JURISDICTIONAL ENGINEER. USE ONLY WITH TYPE B, D, & F RING AND COVER (TELESCOPING).
  - A BOXOUT IS REQUIRED IF TYPE A OR C RING AND COVER IS ALLOWED IN PCC PAVING.
  - WHEN PAVEMENT JOINTS DO NOT INTERSECT THE MANHOLE AT ITS CENTER USE BOXOUT TO PROVIDE JOINT CONTINUITY.
  - SHORTEN JOINTING PATTERN ON EITHER SIDE OF OPENING TO PERMIT JOINTS TO INTERSECT ROUND CASTING AND FALL AT THE EDGES OF BOXOUTS FOR RECTANGULAR STRUCTURES.
  - BOXOUTS ARE REQUIRED WHENEVER A MANHOLE IS REPAIRED IN AN EXISTING PAVEMENT.

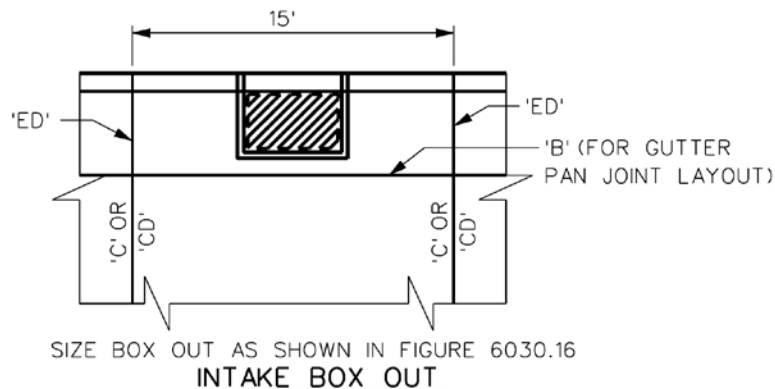

Table 2: Summary of joints

| Joint | Type       |              |           | Method of Load Transfer |     |         |           | Thermal Movement          |                          |                                 |                                     | Comments   |
|-------|------------|--------------|-----------|-------------------------|-----|---------|-----------|---------------------------|--------------------------|---------------------------------|-------------------------------------|--|
|       | Transverse | Longitudinal | Expansion | Aggregate Interlock     | Key | Tie Bar | Dowel Bar | Doweled to allow movement | Tied to prevent movement | Expansion joint allows movement | Lack of reinforcing allows movement |  |
| B     | X          | X            |           |                         |     |         |           |                           |                          |                                 | X                                   | Used between dissimilar materials or when other joints are not suitable.                                       |
| C     | X          |              |           | X                       |     |         |           |                           |                          |                                 | X                                   | Transverse joint used when $T < 8$ in. May also be used on non-primary routes if AADTT $< 200$ vpd.            |
| CD    | X          |              |           | X                       |     |         | X         | X                         |                          |                                 |                                     | Transverse joint used when $T \geq 8$ in. Use C joint when joint length is 2 ft.                               |
| CT    | X          |              |           | X                       |     | X       |           |                           | X                        |                                 |                                     | Specialty tied contraction joint.  |
| DW    | X          |              |           |                         |     | X       |           |                           | X                        |                                 |                                     | Used by contractor as a stopping point.  |
| HT    | X          |              |           |                         |     | X       |           |                           | X                        |                                 |                                     | Used at the end of rigid pavement prior to placement of second slab.   |
| RD    | X          |              |           |                         |     |         | X         | X                         |                          |                                 |                                     | Joint between new and existing pavements, dowels are used.   |
| RT    | X          |              |           |                         |     | X       |           |                           | X                        |                                 |                                     | Joint between new and existing pavements, tie bars are used.   |
| BT-1  |            | X            |           |                         |     |         |           |                           | X                        |                                 |                                     | Longitudinal joint used when $T < 8$ in, interchangeable with L-1 depending on paving sequence.                |
| BT-2  |            | X            |           |                         |     |         |           |                           | X                        |                                 |                                     | Used when L-2 and the KT-2 are not possible, $T \geq 8$ in.  |
| BT-3  |            | X            |           |                         |     |         |           |                           | X                        |                                 |                                     | Joint used between new and existing pavements. Tie bars are used when $T \geq 8$ in.                           |
| BT-4  |            | X            |           |                         |     |         |           |                           | X                        |                                 |                                     | Joint used between new and existing pavements. Tie bars are used when $T \geq 8$ in.                           |
| BT-5  |            | X            |           |                         |     |         |           |                           | X                        |                                 |                                     | Joint used between new and existing pavements. Tie bars are used when $T < 8$ in.                              |
| K     |            | X            |           |                         | X   |         |           |                           |                          |                                 | X                                   | $T > 8$ in, minimal usage.   |
| KS    |            | X            |           |                         | X   |         |           |                           | X                        |                                 |                                     | Used in reinforced pavements.  |
| KT-1  |            | X            |           |                         | X   |         |           |                           | X                        |                                 |                                     | Longitudinal joint used when $T < 8$ in, interchangeable with L-1 depending on paving sequence.                |
| KT-2  |            | X            |           |                         | X   |         |           |                           | X                        |                                 |                                     | Longitudinal joint used when $T \geq 8$ in, interchangeable with L-2 depending on paving sequence.             |
| KT-3  |            | X            |           |                         | X   |         |           |                           | X                        |                                 |                                     | Longitudinal joint used when $T \geq 8$ in, interchangeable with L-3 depending on paving sequence.             |
| L-1   |            | X            |           | X                       |     |         |           |                           | X                        |                                 |                                     | Longitudinal joint used when $T < 8$ in, interchangeable with BT-1.  |
| L-2   |            | X            |           | X                       |     |         |           |                           | X                        |                                 |                                     | Longitudinal joint used when $T \geq 8$ in, interchangeable with KT-2 depending on paving sequence.            |
| L-3   |            | X            |           | X                       |     |         |           |                           | X                        |                                 |                                     | Longitudinal joint used with pavements of large width, interchangeable with KT-3 depending on paving sequence. |
| CF    | X          |              | X         |                         |     |         |           |                           |                          | X                               |                                     | 4 in expansion joint.  |
| E     | X          | X            | X         |                         |     |         |           |                           |                          | X                               |                                     | 1 in expansion joint.  |
| ED    | X          |              | X         |                         |     |         | X         | X                         |                          | X                               |                                     | 1 in doweled expansion joint.  |
| EE    | X          |              | X         |                         |     |         | X         | X                         |                          | X                               |                                     | 2 in doweled expansion joint.  |
| EF    | X          |              | X         |                         |     |         | X         | X                         |                          | X                               |                                     | 4 in doweled expansion joint.  |
| ES    |            |              | X         |                         |     |         |           |                           |                          | X                               |                                     | Used in curb to match expansion joint in pavement.   |

## E. Transverse dowel bar size and length

Table 3 reflects the dowel bar size and length based on the pavement thickness. This information was obtained from the Portland Cement Association, the American Concrete Paving Association, and American Highway Technology. The SUDAS and Iowa DOT Standard Specifications call for dowels when the slab is 8 inches or greater. Dowels are typically set at 12-inch spacings. The designer should note that a dowel bar that is too small induces high bearing stresses and causes the concrete matrix around the dowel to deteriorate or elongate. Elongation of the dowel bar hole then reduces the load transfer capabilities.

**Table 3:** Dowel bar size and length.

| Pavement Thickness<br>(inches) | Dowel Size<br>(diameter in inches) | Dowel Length<br>(inches) |
|--------------------------------|------------------------------------|--------------------------|
| 7.0                            | 3/4                                | 16                       |
| 7.5                            | 3/4                                | 16                       |
| 8                              | 1-1/4                              | 18                       |
| 9                              | 1-1/4                              | 18                       |
| 10                             | 1-1/2                              | 18                       |
| 11                             | 1-1/2                              | 18                       |
| 12                             | 1-1/2                              | 18                       |

## F. Joint reinforced pavements

This section deals primarily with plain jointed pavements as opposed to jointed reinforced (JR) pavements, sometimes referred to as distributed steel reinforcing. Although JR pavements are not common in many local jurisdictions in Iowa, they are used effectively by a select number of cities in the state. Therefore, the following is provided as an explanation of JR pavements:

JR pavements use many of the same type of joints as plain jointed pavements, but the tie bars are replaced with bar mats. The doweled joints are the same for both types of pavements since the bar mats of JR pavements are stopped at the transverse joint. JR pavements should not be confused with continuously reinforced pavement, which has very few joints.

JR pavements are used primarily to control cracking of concrete pavements, to provide for load transfer between joints, and to maintain the structural integrity of the slab between transverse joints. Just like plain jointed pavements, random cracking of JR pavements may still occasionally occur even though the steel is present. The steel serves to hold the edges of the crack close together, thus preventing the progressive opening of the cracks over time.

The cost of the added reinforcement for JR pavements is often offset by specifying a somewhat thinner slab. However, as pointed out by the American Concrete Institute (ACI), the use of reinforcing steel will not “add to the load-carrying capacity of the pavement nor compensate for poor subgrade preparation or poor construction practices.” By holding random cracks tightly closed, it will maintain the shear resistance of the slab, and consequently, will maintain its load carrying capacity. This improves the ride when the vertical displacement is controlled.

Refer to the SUDAS Standard Specifications Figures 7010.1F and 7010.1G for the joint reinforced pavement details.