

**GUTTERLINE JOINTING**

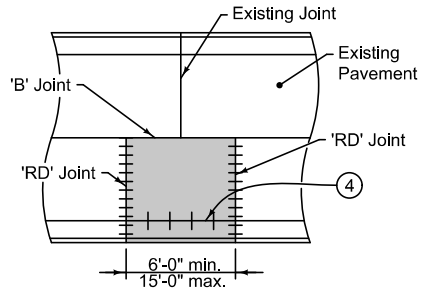

**ONE PANEL WIDTH PATCH WITH OPPOSING JOINT**

**THIRD POINT JOINTING**

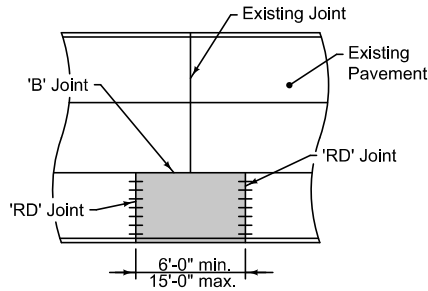

**OUTSIDE PANEL PATCH WITH OPPOSING JOINT**

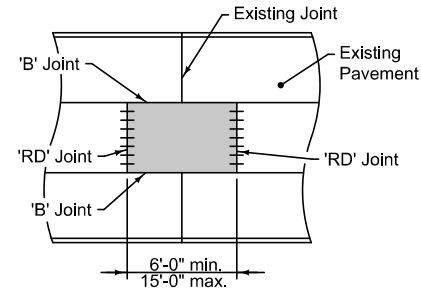

**CENTER PANEL PATCH WITH OPPOSING JOINTS**

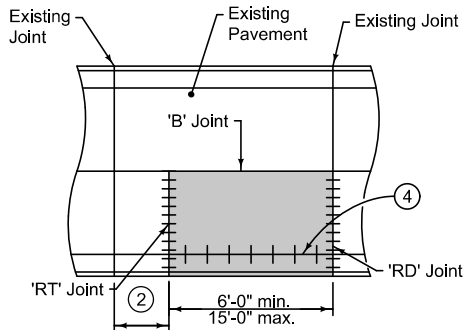

**ONE PANEL WIDTH PATCH NO OPPOSING JOINT**

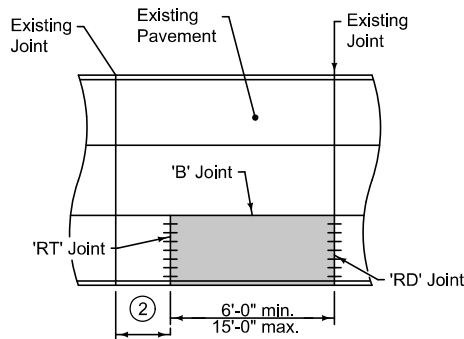

**OUTSIDE PANEL PATCH NO OPPOSING JOINT**

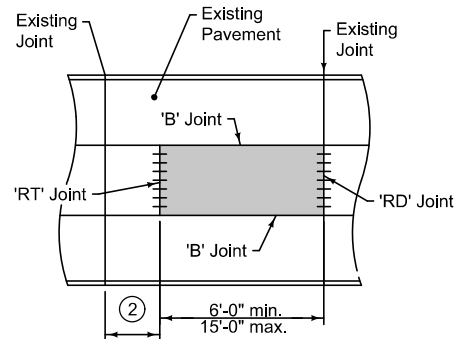

**CENTER PANEL PATCH NO OPPOSING JOINT**

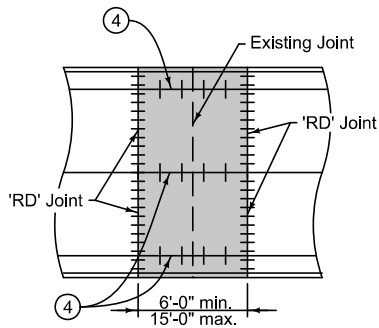

**FULL ROADWAY WIDTH PATCH**

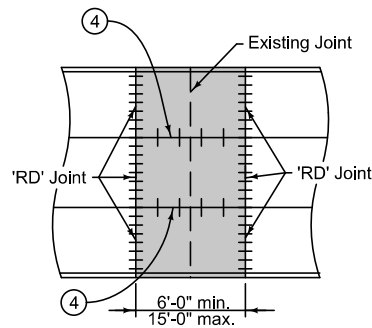

**FULL ROADWAY WIDTH PATCH**

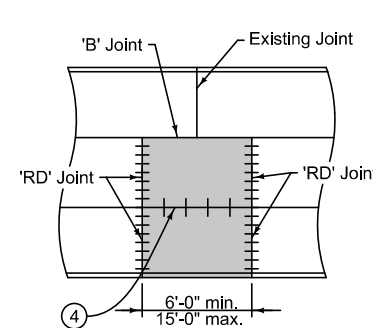

**ADJACENT PANELS PATCH**

- ① Patches on roadways with quarter point jointing will be similar to third point jointing details.
- ② Minimum distance between existing joint and patch is 6 feet. If distance is less than 6 feet, extend patch to existing joint.
- ③ If subgrade or subbase material is required below patch, bring material to a level 2 inches below bottom of existing pavement.
- ④ BT, KT, or L joint depending on pavement thickness and pouring sequence.

**LONGITUDINAL SECTION THRU PCC PATCH**

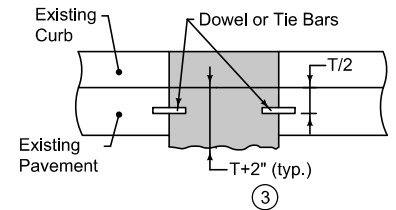

FIGURE 7040.101 SHEET 1 OF 1

	REVISION
	3   2021 Edition
	<b>7040.101</b>
SHEET 1 of 1	

SUDAS Standard Specifications

FULL DEPTH PCC PATCHES LESS THAN OR EQUAL TO 15' LONG