

**Table of Contents**

<b>Section 11,010 - Construction Survey</b>		<b>Page No.</b>
<b>Part 1 - General</b>		
1.01	Section Includes	1
1.02	Description of Work	1
1.03	Submittals	1
1.04	Substitutions	2
1.05	Delivery, Storage, and Handling	2
1.06	Scheduling and Conflicts	2
1.07	Special Requirements	2
1.08	Measurement and Payment	2
<b>Part 2 - Products</b>		
2.01	Hubs	4
2.02	Lath	4
<b>Part 3 - Execution</b>		
3.01	Equipment	5
3.02	Project Control	5
3.03	Construction Staking	6
3.04	Monument Preservation and Replacement	8
<b>Section 11,020 - Mobilization</b>		
<b>Part 1 - General</b>		
1.01	Section Includes	1
1.02	Description of Work	1
1.03	Submittals	1
1.04	Substitutions	1
1.05	Delivery, Storage, and Handling	1
1.06	Scheduling and Conflicts	1
1.07	Special Requirements	1
1.08	Measurement and Payment	1

<b>Section 11,020 - Mobilization (Continued)</b>	<b>Page No.</b>
<b>Part 2 - Products</b>	
None.	2
<b>Part 3 - Execution</b>	
None.	2
<b>Section 11,030 - Temporary Services During Construction</b>	
<b>Part 1 - General</b>	
1.01 Section Includes	1
1.02 Description of Work	1
1.03 Submittals	1
1.04 Substitutions	1
1.05 Delivery, Storage, and Handling	1
1.06 Scheduling and Conflicts	1
1.07 Special Requirements	1
1.08 Measurement and Payment	1
<b>Part 2 - Products</b>	
2.01 Mailboxes	2
<b>Part 3 - Execution</b>	
3.01 Postal Service	3
3.02 Solid Waste Collection	3
<b>Figure</b>	<b>Figure No.</b>
Temporary Mailboxes	11030.101
<b>Section 11,040 - Temporary Sidewalk Access</b>	
<b>Part 1 - General</b>	
1.01 Section Includes	1
1.02 Description of Work	1
1.03 Submittals	1
1.04 Substitutions	1
1.05 Delivery, Storage, and Handling	1
1.06 Scheduling and Conflicts	1

<b>Section 11,040 - Temporary Sidewalk Access (Continued)</b>		<b>Page No.</b>
1.07	Special Requirements	1
1.08	Measurement and Payment	1
<b>Part 2 - Products</b>		
2.01	Granular Surfacing	3
2.02	Temporary Longitudinal Channelizing Device	3
<b>Part 3 - Execution</b>		
3.01	Temporary Pedestrian Residential Access	4
3.02	Temporary Granular Sidewalk	4
3.03	Temporary Longitudinal Channelizing Device	4
<b>Figures</b>		<b>Figure No.</b>
	Temporary Granular Sidewalk and Temporary Residential Access	11040.101
	Temporary Pedestrian Channelizing Device	11040.102
<b>Section 11,050 - Concrete Washout</b>		<b>Page No.</b>
<b>Part 1 - General</b>		
1.01	Section Includes	1
1.02	Description of Work	1
1.03	Submittals	1
1.04	Substitutions	1
1.05	Delivery, Storage, and Handling	1
1.06	Scheduling and Conflicts	1
1.07	Special Requirements	1
1.08	Measurement and Payment	1
<b>Part 2 - Products</b>		
2.01	Concrete Washout	2
<b>Part 3 - Execution</b>		
3.01	Concrete Washout	3
3.02	Cleanup and Removal	3



---

**CONSTRUCTION SURVEY****PART 1 - GENERAL****1.01 SECTION INCLUDES**

Construction survey includes personnel, equipment, and supplies required for, but not limited to, the following:

- A. Construction Survey:
  - 1. Project Control
  - 2. Grading
  - 3. Bridges, Structural Walls, and Reinforced Box Culverts
  - 4. Pipe Culverts
  - 5. Sanitary and Storm Sewers
  - 6. Water Mains
  - 7. Paving
  - 8. Replacement of Disturbed Monuments
  - 9. Additional Items Included in the Contract Documents
- B. Monument Preservation and Replacement

**1.02 DESCRIPTION OF WORK**

Construction survey and staking necessary for construction of the project as shown in the contract documents.

**1.03 SUBMITTALS**

Comply with Division 1 - General Provisions and Covenants, as well as the following:

- A. **Documentation:** Format the survey work documentation in a manner acceptable to the Engineer. Ensure documentation is sufficient to prove means and methods used to transfer design intent to construction stakes. Check tie-ins with existing roadways, structures, and utilities prior to staking; notify the Engineer if discrepancies are found.
  - 1. **Benchmarks:** Submit descriptions and elevations of new permanent benchmarks. Establish benchmarks on existing durable fixtures not subject to frost action or disturbance.
  - 2. **Staking Records:** Upon request, submit all field books, computer-aided design and drafting (CADD) files, digital log files, etc.
  - 3. **Monument Preservation and Replacement:** If the contract documents include a bid item for monument preservation and replacement, submit copies of all documents developed for compliance with the requirements of Iowa Code Section 355 and Iowa Administrative Code 193C to the Engineer.

**1.04 SUBSTITUTIONS**

Comply with Division 1 - General Provisions and Covenants.

**1.05 DELIVERY, STORAGE, AND HANDLING**

Comply with Division 1 - General Provisions and Covenants.

**1.06 SCHEDULING AND CONFLICTS**

Comply with Division 1 - General Provisions and Covenants.

**1.07 SPECIAL REQUIREMENTS****A. Qualifications:**

1. Perform construction survey directly by or under responsible charge of a Professional Engineer or Professional Land Surveyor licensed in the State of Iowa.
2. Reset disturbed monuments with new monuments under the responsible charge of a Professional Land Surveyor licensed in the state of Iowa.

**B.** Obtain Engineer's approval when interpolating grades or using cross-sections to obtain alignments and elevations.

**C.** The Jurisdiction will provide benchmarks, right-of-way corners, and primary control points from the original survey in the contract documents. Roadway alignment data will be provided as required for construction.

**D.** If the contract documents do not include a bid item for monument preservation and replacement, the Contracting Authority will be responsible for replacing disturbed monuments located within the project area and not noted for protection.

**1.08 MEASUREMENT AND PAYMENT**

**A. Construction Survey:** If the contract documents specify that the Contractor is responsible for construction survey, measurement and payment will be as follows.

1. **Measurement:** Lump sum item; no measurement will be made.
2. **Payment:** Payment will be at the lump sum price for construction survey.
3. **Includes:** Lump sum price includes, but is not limited to, the costs of resetting project control points, re-staking, and any additional staking requested beyond the requirements of this section.

**1.08 MEASUREMENT AND PAYMENT (Continued)**

**B. Monument Preservation and Replacement:** If the contract documents specify the Contractor is responsible for replacing monuments, measurement and payment will be as follows.

1. **Measurement:** Lump sum item; no measurement will be made.
2. **Payment:** Payment will be at the lump sum price for replacement of disturbed monuments.
3. **Includes:** Lump sum price includes, but is not limited to, property research and documentation, locating monuments prior to construction, replacement of disturbed monuments, and preparation and filing of the monument preservation certificate.

**PART 2 - PRODUCTS****2.01 HUBS**

Provide hardwood, metal, or plastic stakes of sufficient size and length to prevent stake movement due to adjacent construction activity.

**2.02 LATH**

Provide wood lath that is approximately 3/8 inch thick by 1 1/2 inches wide by 48 inches long.



---

**PART 3 - EXECUTION****3.01 EQUIPMENT**

- A. Utilize survey equipment with a level of accuracy appropriate for the type of work being staked.
- B. Do not use GPS equipment for staking the vertical elements of paving hubs, bridges, structural walls, or reinforced box culverts.

**3.02 PROJECT CONTROL**

Provide all horizontal and vertical control data to the Jurisdiction at the completion of each phase of the construction survey work activity.

- A. Primary Monuments:** Primary survey monuments are established by the Jurisdiction prior to project construction.
  - 1. Replace primary monuments disturbed by construction.
  - 2. Reference a minimum of three ties to durable objects (trees, fence posts, station marks, etc.) in the description of the new monument.
- B. Secondary Monuments:** Secondary control points are established by the Contractor or Contractor's Surveyor during construction to facilitate staking or instrument calibration.
  - 1. Place in locations likely to survive construction.
  - 2. Reference to the primary monuments with a resulting error radius not to exceed 0.10 feet.
  - 3. Replace any points disturbed during construction. Points do not need to be replaced after construction.
- C. Benchmarks:** Utilize the benchmarks shown in the contract documents to establish all other vertical control on the project site.
  - 1. Establish new permanent vertical control benchmarks on new structures (bridges, reinforced box culverts), fire hydrants, or power poles located in the project limits.
  - 2. Identify permanent benchmarks.
  - 3. Transfer elevations from construction plan benchmarks to new permanent benchmarks using a digital level or a three-wire leveling method.
  - 4. Record descriptions and elevations of new permanent benchmarks.
- D. Property Limits:** If specified, mark all construction easements, permanent easements, and rights-of-way with flagged lath at 100 feet intervals on tangents; at the PC and PT of curves; at 25 feet intervals on curves; and at all angle points.

### 3.03 CONSTRUCTION STAKING

For each construction operation specified in the contract documents, provide stakes as follows. If approved by the Engineer, staking frequency may be modified as long as the level of accuracy appropriate for the type of work is achieved.

#### A. Grading:

##### 1. Conventional Grading:

- a. Set slope stakes left and right (nails or wood hubs) at 100 foot intervals, or less if needed, for all embankment or roadway excavation. Mark slope stakes with wooden lath depicting station, offset, and elevation reference (cut or fill) to all pertinent breaks in the slope.
- b. In lieu of slope stakes, set a 100 foot grid with lath over project limits for mass grading with cut or fill marked for finished grade elevation. Finished grade refers to the finished surface of construction (top of paving for paved areas, top of black dirt for unpaved areas).
- c. For paved areas, in addition to the 100 foot grid, set lath at appropriate offsets around the perimeter at 50 foot intervals, high and low points, and points of inflection. Mark lath with cut or fill to finished grade (top of paving).
- d. For building pads, set lath at appropriate offsets for building corners or gridlines. Provide a semi-permanent benchmark, consisting of a 2 foot wooden hub or rebar, set to the same elevation as the proposed finished floor elevation.
- e. Set finished grade stakes (blue tops) at 100 foot intervals at both edges of paving and along centerline for roadways, and in a 100 foot grid in parking areas. Mark blue tops with a stake chaser or similar method.

##### 2. GPS Machine-Controlled Grading:

- a. Establish GPS control points consisting of a minimum of 5 semi-permanent points located around the perimeter of the site. Points may be established horizontally using GPS, but transfer elevations of said points from an original benchmark located in the construction documents using a total station or level.
- b. Provide grade check stakes at an approximate spacing of 300 feet on roadways.
- c. Provide approximately 20 grade control check stakes for building pad and parking areas.

#### B. Bridges, Structural Walls, and Reinforced Concrete Box Culverts:

1. Provide appropriate offsets for centerline of abutments, piers, back of parapets, face of walls, etc.
2. Provide stakes consisting of a tacked wooden hub with a lath. Clearly mark offset distance and referenced line identification: centerline roadway, abutment, pier, etc.
3. Clearly mark height of cut or fill to a pre-determined elevation reference: flowline, top of wall, top of footing, etc. For structural walls, provide elevation reference to either top of wall or top of footing. Do not reference off of bottom of wall.
4. Set a minimum of two semi-permanent benchmarks, consisting of a 2 foot wooden hub or rebar, for each structure. Transfer elevation to benchmarks from construction plan benchmarks using a total station or level.

**3.03 CONSTRUCTION STAKING (Continued)**

5. Perform an independent check of all the above stakes. Independent check can be performed by an independent survey crew or by arbitrary verification of the location of the stakes as placed in the field.
  - a. For an arbitrary verification, survey stakes and control points in an arbitrary coordinate system and then rotate digitally into the design file to verify accuracy with the contract documents.
  - b. Notify Contractor of any discrepancies within 24 hours of placing the stakes for each structure.

**C. Pipe Culverts:**

1. Place stakes for offsets to ends of pipe, labeled with offset distance, and cut or fill to proposed flowline of the new culvert.
2. Place stakes for all bends in the pipe alignment. Provide two offset stakes, one along each pipe segment bearing, at bends to accurately place bend location.
3. For culverts over 100 feet in length, set offset stakes 50 feet and 100 feet from end of pipe and every 100 feet thereafter. Label stakes with offset distance and elevation reference to the flowline of the proposed pipe.

**D. Sanitary and Storm Sewers:**

1. Place stakes for all manholes, intakes, cleanouts, and other structures associated with new sewer.
2. Provide offset stake for each structure set at 10 to 15 feet. Offset may be increased for deep sewers.
3. For back of curb intakes, set two offset stakes along the curb alignment to properly align the new grate. Stakes may also be offset perpendicular to the curb alignment as required to avoid conflicts with the proposed storm sewer.
4. Place stakes for all bends in the pipe alignment. Provide two offset stakes, one along each pipe segment bearing, at bends to accurately place bend location.
5. For pipe sections over 100 feet in length, set offset stakes 50 feet and 100 feet from end of pipe and every 100 feet thereafter. Label stakes with offset distance and elevation reference to the flowline of the proposed pipe.

**E. Water Mains:**

1. Place stakes for proposed water main on line (no offset) at 100 foot intervals. Label stakes as centerline of water main with elevation reference to the top of the proposed pipe to ensure sufficient depth is achieved.
2. Place stakes for all hydrants, valves, bends, tees, and other appurtenances with appropriate offsets. Label stakes with offset distance and elevation reference to proposed finished grade adjacent to the hydrant, valve, bend, tee, or other appurtenance.
3. Place stakes at all crossings of storm sewers and sanitary sewers. Label stakes with top of pipe elevations at the crossing for water mains and sewer mains to ensure proper depth and vertical separation.

**3.03 CONSTRUCTION STAKING (Continued)****F. Paving:****1. Conventional Paving:**

- a. Set paving hubs at appropriate offsets around perimeter of paved areas. Place hubs at grade breaks (high and low points), points of horizontal deflection (bends), and 25 foot intervals in between. Label stakes with offset distance and elevation reference to the top of paving.
- b. For paving areas wider than 60 feet, set paving hubs at appropriate offsets on 25 foot intervals along interior bays or drive lanes. Label stakes with offset distance and elevation reference to the top of paving.
- c. Place stakes for curb drop locations for sidewalk ramps and driveways. Set hubs on both sides of the drop curb at the bottom of the drop to ensure the appropriate width of curb opening is achieved. Label stakes with offset distance and elevation reference to top of paving.
- d. Place stakes for sidewalks and trails on one side only at appropriate offsets. Place stakes at 50 foot intervals in straight and level sections and 25 foot intervals for horizontal or vertical curves. Label stakes with offset distance and elevation reference to the top of paving.

**2. Stringless Paving:**

- a. When stringless paving is used, set additional control points on each side of the pavement, as necessary, to meet the manufacturer's requirements for the equipment used. Furnish x, y, and z coordinates and station offset information for each point. Points may be established horizontally using GPS, but transfer elevations of said points from an original benchmark located in the construction documents using a total station or level.
- b. Provide grade check paving hubs at appropriate offsets around the perimeter of the paved areas. Location and elevation of the finished slab should be verified against grade check hubs at 25 foot intervals for the first 100 feet of each days run and at critical locations, such as intakes and through intersections where grades may be flat. The Engineer may waive these requirements if experience has shown compliance with the design elevations.
- c. Place stakes for curb drop locations for sidewalk ramps and driveways. Set hubs on both sides of the drop curb at the bottom of the drop to ensure the appropriate width of curb opening is achieved. Label stakes with offset distance and elevation reference to top of paving.
- d. Provide grade check stakes for sidewalks and shared use paths at appropriate offset on one side only. Provide grade check stakes for sidewalks and shared use paths at a maximum interval spacing of 100 feet.

**3.04 MONUMENT PRESERVATION AND REPLACEMENT**

Comply with the requirements of Iowa Code Section 355 and the Iowa Administrative Code Section 193C for the replacement of all disturbed monuments within the project area.

END OF SECTION

---

**MOBILIZATION****PART 1 - GENERAL****1.01 SECTION INCLUDES**

Project Mobilization

**1.02 DESCRIPTION OF WORK**

Mobilization includes preparatory work, operations performed, or costs incurred prior to beginning work on the various items on the project site.

**1.03 SUBMITTALS**

Comply with Division 1 - General Provisions and Covenants.

**1.04 SUBSTITUTIONS**

Comply with Division 1 - General Provisions and Covenants.

**1.05 DELIVERY, STORAGE, AND HANDLING**

Comply with Division 1 - General Provisions and Covenants.

**1.06 SCHEDULING AND CONFLICTS**

Comply with Division 1 - General Provisions and Covenants.

**1.07 SPECIAL REQUIREMENTS**

- A. When a bid item for mobilization is included on the proposal form, comply with this section for measurement and payment.
- B. When the proposal form does not include a bid item for mobilization, all costs incurred by the contractor for mobilization are incidental to other work and no separate payment will be made.

**1.08 MEASUREMENT AND PAYMENT****A. Mobilization:**

- 1. **Measurement:** Lump sum item; no measurement will be made.
- 2. **Payment:**
  - a. When 5% of the original contract amount has been completed, 25% of the contract price for mobilization will be paid.
  - b. When 10% of the original contract amount has been completed, 50% of the contract price for mobilization will be paid.
  - c. When 50% of the original contract amount has been completed, 100% of the contract price for mobilization will be paid.
- 3. **Includes:** The unit price for mobilization may include the following.
  - a. The movement of personnel, equipment, and supplies to the project site.
  - b. The establishment of offices, buildings, and other facilities necessary for the project.
  - c. Bonding, permits, or other expenses incurred prior to construction.

**PART 2 - PRODUCTS**

None.

**PART 3 - EXECUTION**

None.

END OF SECTION

---

**TEMPORARY SERVICES DURING CONSTRUCTION****PART 1 - GENERAL****1.01 SECTION INCLUDES**

- A. Maintenance of Postal Service
- B. Coordination of Solid Waste Collection

**1.02 DESCRIPTION OF WORK**

- A. Maintain postal service to all properties within the project area.
- B. Maintain solid waste collection to all properties within the project area. Solid waste includes garbage, recycling, and yard waste.

**1.03 SUBMITTALS**

Comply with Division 1 - General Provisions and Covenants.

**1.04 SUBSTITUTIONS**

Comply with Division 1 - General Provisions and Covenants.

**1.05 DELIVERY, STORAGE, AND HANDLING**

Comply with Division 1 - General Provisions and Covenants.

**1.06 SCHEDULING AND CONFLICTS**

Comply with Division 1 - General Provisions and Covenants.

**1.07 SPECIAL REQUIREMENTS**

None.

**1.08 MEASUREMENT AND PAYMENT****A. Maintenance of Postal Service:**

1. **Measurement:** Lump sum item; no measurement will be made.
2. **Payment:** Payment will be at the lump sum price for maintenance of postal service.
3. **Includes:** Lump sum price includes, but is not limited to, coordinating with USPS and erecting and maintaining temporary mailboxes.

**B. Maintenance of Solid Waste Collection:**

1. **Measurement:** Lump sum item; no measurement will be made.
2. **Payment:** Payment will be at the lump sum price for maintenance of solid waste collection.
3. **Includes:** Lump sum price includes, but is not limited to, coordinating and maintaining solid waste collection services including establishing alternate collection sites if required.

**PART 2 - PRODUCTS**

**2.01 MAILBOXES**

- A. Curbside Mailboxes:** Provide standard curbside mailboxes complying with US Postal Service (USPS) STD-7B.
- B. Cluster Mailboxes:** Provide cluster box units complying with USPS-B-1118.



**PART 3 - EXECUTION****3.01 POSTAL SERVICE**

- A. Coordinate delivery of mail with the USPS.
- B. Maintain postal service to all properties within the project area. Meet the needs of physically challenged individuals within the project area.
- C. When construction staging prohibits access to normal mailbox locations by the USPS, establish temporary mail service as follows:
  - 1. Coordinate with the USPS to establish an acceptable location for a temporary group mailbox.
  - 2. Verify proposed location with the Engineer prior to installation.
  - 3. Erect and maintain a temporary group mailbox or provide a temporary USPS approved cluster box unit complying with [Figure 11,030.101](#).

**3.02 SOLID WASTE COLLECTION**

- A. Coordinate collection of solid waste with property owners and the solid waste collection agencies operating in the project area.
- B. Maintain access for solid waste collection vehicles during construction.
- C. When construction staging prohibits access to normal collection locations by solid waste collection vehicles, comply with the following:
  - 1. Coordinate with solid waste collection agencies to establish a common location for collection outside the inaccessible area.
  - 2. Coordinate with residents/businesses within the project area for the alternate solid waste collection procedures.
  - 3. Affix a temporary label to solid waste containers identifying the property owner's or renter's name or address.
  - 4. Prior to the normal collection time, gather containers from properties within the inaccessible area, and transport to the common location accessible by solid waste collection vehicles.
  - 5. Return solid waste containers to each property within 24 hours after collection.

END OF SECTION



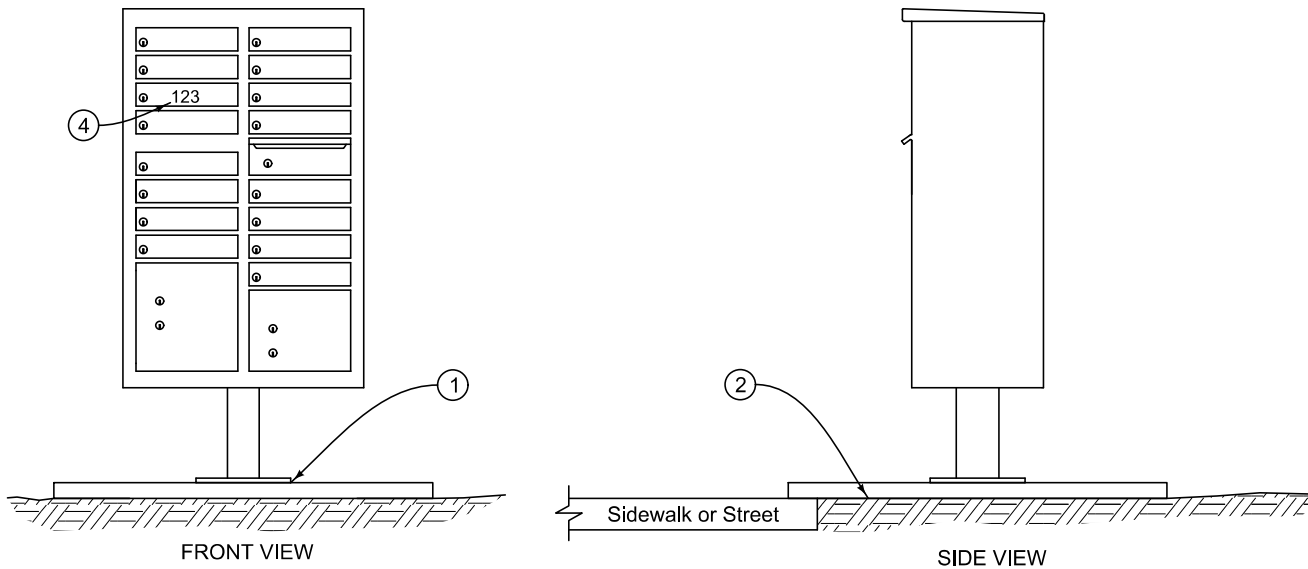

TEMPORARY CLUSTER BOX UNIT

- ① Attach cluster box unit to a stable skid or anchor plate.
- ② Set cluster box on firm and level ground adjacent to sidewalk or street paving. Provide anchorage as needed to prevent overturning.
- ③ Provide a 2 inch x 12 inch plank with length as required. Firmly attach mailboxes and newspaper tubes to plank. Secure plank to steel posts for lateral support.
- ④ Label each mailbox with property address.
- ⑤ Attach two bands of 2 inch wide reflectorized tape to each barrel.

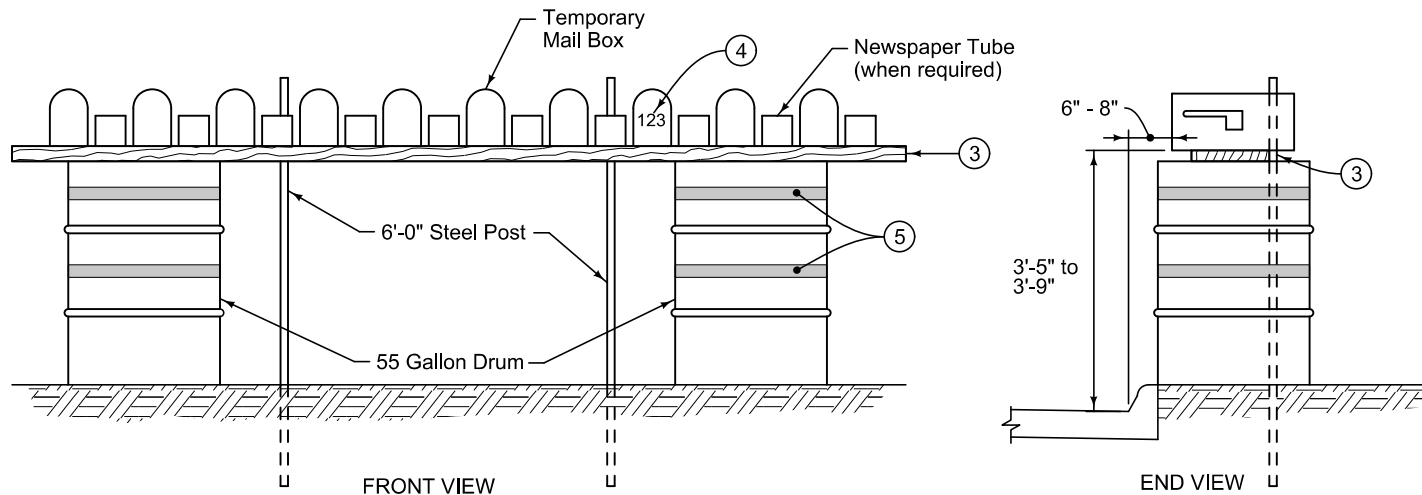

TEMPORARY GROUP MAILBOX

FIGURE 11030.101 SHEET 1 OF 1

	<small>REVISION</small> 1   10-18-16
	<b>SUDAS</b> <b>11030.101</b> <small>SHEET 1 of 1</small>
SUDAS Standard Specifications	
TEMPORARY MAILBOXES	



---

**TEMPORARY SIDEWALK ACCESS****PART 1 - GENERAL****1.01 SECTION INCLUDES**

- A. Temporary Residential Access
- B. Temporary Granular Sidewalk
- C. Temporary Longitudinal Channelizing Device

**1.02 DESCRIPTION OF WORK**

- A. Construct a temporary access to residential properties impacted by construction.
- B. Construct a granular surfaced, temporary, public sidewalk.
- C. Construct temporary longitudinal channelizing device along a public sidewalk to delineate the pedestrian access route.

**1.03 SUBMITTALS**

Comply with Division 1 - General Provisions and Covenants.

**1.04 SUBSTITUTIONS**

Comply with Division 1 - General Provisions and Covenants.

**1.05 DELIVERY, STORAGE, AND HANDLING**

Comply with Division 1 - General Provisions and Covenants.

**1.06 SCHEDULING AND CONFLICTS**

Comply with Division 1 - General Provisions and Covenants.

**1.07 SPECIAL REQUIREMENTS**

None.

**1.08 MEASUREMENT AND PAYMENT****A. Temporary Pedestrian Residential Access:**

1. **Measurement:** Granular surfacing for temporary pedestrian residential access will be measured in square yards.
2. **Payment:** Payment for temporary pedestrian residential access will be made at the unit price per square yard.
3. **Includes:** The unit price for temporary pedestrian residential access includes, but is not limited to, supplying and placing granular material, continuous maintenance of granular surface, removal of temporary granular sidewalk, and restoring disturbed surfaces to a condition equal to that which existed prior to construction.

**1.08 MEASUREMENT AND PAYMENT (Continued)****B. Temporary Granular Sidewalk:**

1. **Measurement:** Temporary granular sidewalk will be measured in square yards.
2. **Payment:** Payment for temporary granular sidewalk will be made at the unit price per square yard.
3. **Includes:** The unit price for temporary granular sidewalk includes, but is not limited to, excavation, grading, timber edging, supplying and placing granular material, continuous maintenance of granular surface, removal of temporary granular sidewalk, and restoring disturbed surfaces to a condition equal to that which existed prior to construction.

**C. Temporary Longitudinal Channelizing Device:**

1. **Measurement:** Temporary longitudinal channelizing device will be measured in linear feet along the top rail support.
2. **Payment:** Payment for longitudinal channelizing device will be made at the unit price per linear foot.
3. **Includes:** The unit price for temporary longitudinal channelizing device includes, but is not limited to, construction, placement, maintenance, and removal of the device.

**PART 2 - PRODUCTS****2.01 GRANULAR SURFACING**

Provide fine limestone complying with [Iowa DOT Article 4109.02](#), [Gradation No. 8](#) in the Aggregate Gradation Table and the quality requirements of [Iowa DOT Article 4117.03](#) for temporary residential access or a temporary granular sidewalk.

**2.02 TEMPORARY LONGITUDINAL CHANNELIZING DEVICE**

- A. Construct channelizing device from common dimensional lumber and construction fasteners. Comply with [Figure 11040.102](#).
- B. Provide a manufactured pedestrian guidance system complying with the requirements of the *American's with Disabilities Act Accessibility Guidelines for Buildings and Facilities* (ADAAG) and the MUTCD.
- C. Other alternatives that comply with the ADAAG and MUTCD requirements may be allowed upon approval of the Engineer.

**PART 3 - EXECUTION****3.01 TEMPORARY PEDESTRIAN RESIDENTIAL ACCESS**

This item is for the construction of a temporary granular path through the project area for pedestrian access to residential properties when street and sidewalk access area is impacted by construction. This access is not intended to provide access to the general public.

- A. Construct a 4 foot wide granular path through the project area as required to maintain access to residential properties.
- B. Place granular material directly on the existing surface to a nominal depth of 3 inches.
- C. Grade the granular surface smooth and compact.
- D. Maintain the surface of the path in a firm, stable, and slip resistant condition.
- E. Relocate or replace path as required by construction staging.
- F. Place additional granular material as directed by the Engineer.

**3.02 TEMPORARY GRANULAR SIDEWALK**

- A. Construct temporary granular sidewalk at locations specified in the contract documents.
- B. Excavate existing ground surface to a nominal depth of 4 inches. Install 2 by 4 edging along both sides of the excavation.
- C. Place granular surfacing between edging and compact.
- D. Maintain the surface of the granular sidewalk in a firm, stable, and slip resistant condition.
- E. Place additional granular material as directed by the Engineer.

**3.03 TEMPORARY LONGITUDINAL CHANNELIZING DEVICE**

- A. Construct temporary longitudinal channelizing device according to [Figure 11040.102](#), or erect manufactured or other approved pedestrian railing system.
- B. Locate device as specified in the contract documents.
- C. Add additional posts, braces, base plates, screws, nails, sandbags, or other appurtenances as required to maintain device in a stable condition at no additional cost to the Contracting Authority.

END OF SECTION



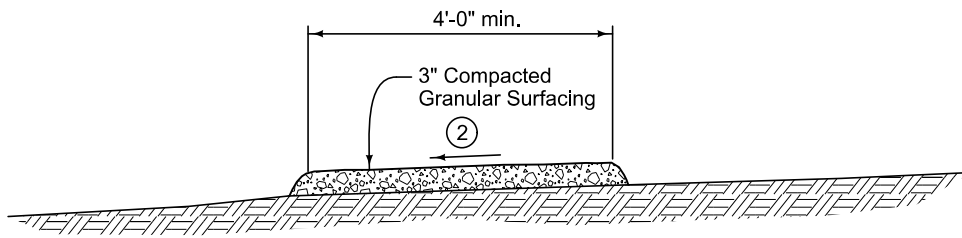

TEMPORARY RESIDENTIAL ACCESS

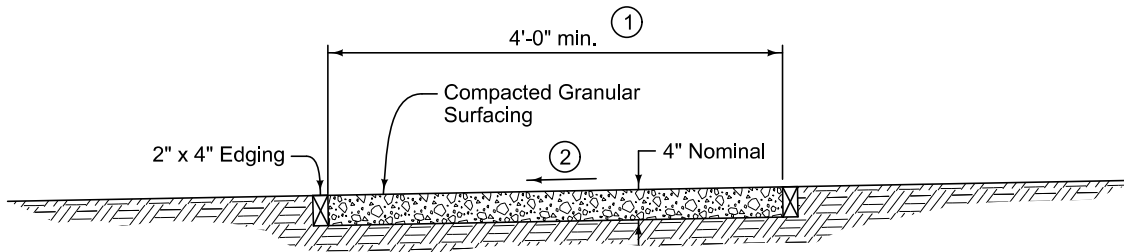

TEMPORARY GRANULAR SIDEWALK

- ① If sidewalk width is less than 5 feet, provide 5 foot long by 5 foot wide passing spaces at 200 foot intervals.
- ② Target cross slope of 1.5% with a maximum cross slope of 2%.

	REVISION	
	1	10-18-16
	11040.101	
SHEET 1 of 1		
SUDAS Standard Specifications		
TEMPORARY GRANULAR SIDEWALK AND TEMPORARY RESIDENTIAL ACCESS		



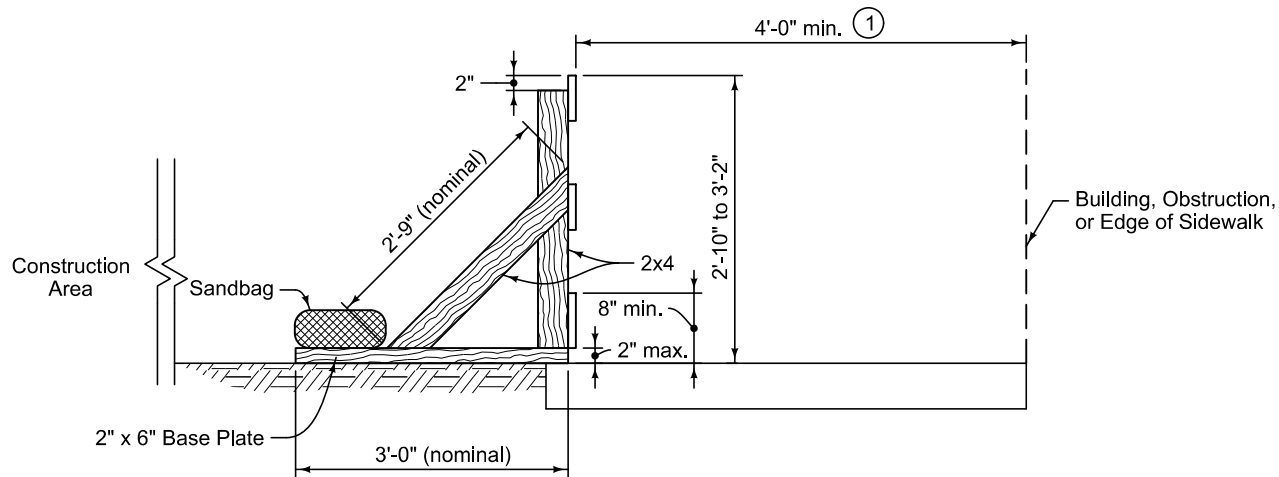

END VIEW

- ① If sidewalk width is less than 5 feet, provide 5 foot long by 5 foot wide passing spaces at 200 foot intervals.
- ② Provide non-reflective orange and white sheeting on top and bottom rails.
- ③ Attach 12 inch long splice boards on the back side of rails at joints between sections.
- ④ When specified in the contract documents, install orange construction safety fence between the top of the bottom rail and the bottom of the top rail.

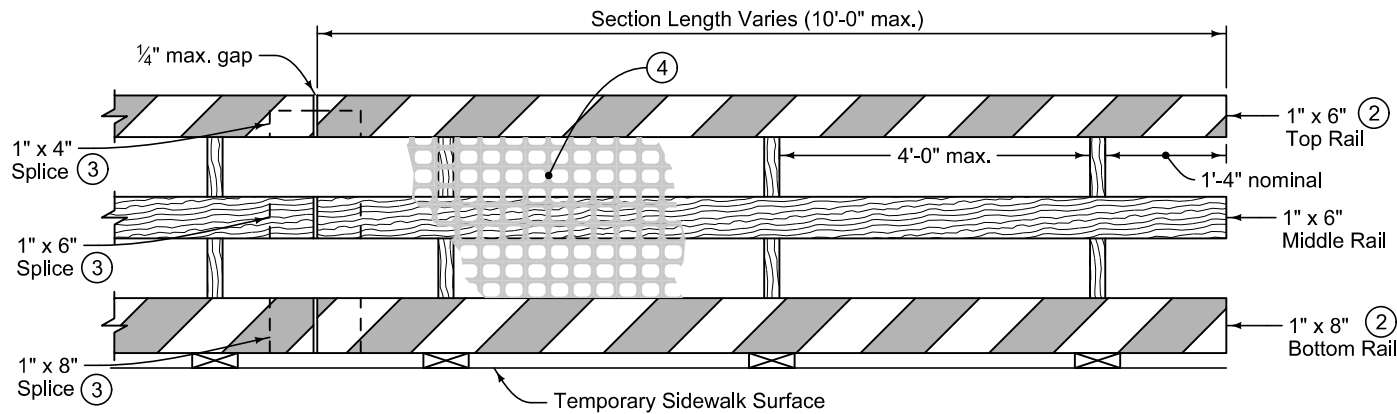

FRONT VIEW

	<small>REVISION</small> 1   10-18-16
	<b>SUDAS</b> <b>11040.102</b>
	<small>SHEET 1 of 1</small>
<b>SUDAS Standard Specifications</b>	
<b>TEMPORARY PEDESTRIAN CHANNELIZING DEVICE</b>	



**CONCRETE WASHOUT****PART 1 - GENERAL****1.01 SECTION INCLUDES**

Concrete Washout

**1.02 DESCRIPTION OF WORK**

Provide and maintain concrete washout system.

**1.03 SUBMITTALS**

Comply with Division 1 - General Provisions and Covenants.

**1.04 SUBSTITUTIONS**

Comply with Division 1 - General Provisions and Covenants.

**1.05 DELIVERY, STORAGE, AND HANDLING**

Comply with Division 1 - General Provisions and Covenants.

**1.06 SCHEDULING AND CONFLICTS**

Comply with Division 1 - General Provisions and Covenants.

**1.07 SPECIAL REQUIREMENTS**

None.

**1.08 MEASUREMENT AND PAYMENT****A. Concrete Washout:**

1. **Measurement:** Lump sum item; no measurement will be made.
2. **Payment:** Payment will be at the lump sum price for concrete washout.
3. **Includes:** Lump sum price includes, but is not limited to, providing concrete washwater containment, collection, and disposal.

**PART 2 - PRODUCTS****2.01 CONCRETE WASHOUT**

Provide a concrete washout system that retains all concrete washwater and complies with one of the following:

**A. Manufactured Washout Containment:**

1. **Concrete Washout Containers:** Provide roll-off type metal container that is leak-proof and designed specifically for collection of concrete and concrete washwater. When concrete pumper trucks are utilized, provide a ramp or other means to allow access for pumper trucks.
2. **Concrete Washout Collection Bags:** Provide leak-proof collection bags designed specifically for collection of concrete and concrete washwater.
3. **Chute Washout Box:** Provide ready mixed trucks with on-vehicle chute washout system to collect concrete washwater for return to the ready mixed plant.

**B. Non-Manufactured Containment:**

1. **Below-grade System:** For excavated pits, provide an impermeable plastic liner with a minimum thickness of 10 mils.
2. **Above-grade Containment:** For containment areas constructed from earthen berms, provide a double thickness of impermeable plastic liner with a minimum thickness of 10 mil per sheet.

- C. Prohibited Products:** Silt fence, unlined hay bales, unlined earthen embankments, and other practices that may allow concrete washwater to leak out of the containment area or to come in direct contact with the ground are not allowed.

**PART 3 - EXECUTION****3.01 CONCRETE WASHOUT**

- A. Provide concrete washwater containment on all projects where concrete washwater will be generated. Clearly mark the location of the washout area and provide directions to truck drivers.
- B. Locate concrete washout containment systems a minimum of 50 feet from proposed or existing storm sewer intakes, open ditches, or waterbodies.
- C. Collect all concrete washwater from ready mixed trucks, pumper trucks, and cleaning of tools and other equipment.
- D. Retain concrete washwater within the containment system until the water evaporates or is collected and disposed.
- E. Prior to rain events, lower the liquid level or cover the concrete washout containment area to prevent overflow.
- F. Clean out the concrete washwater containment area when it reaches 75% of the total capacity.
- G. Hardened solids may be removed from the containment area and disposed of as other non-hazardous wastes or may be broken up and used on the site for other appropriate uses.

**3.02 CLEANUP AND REMOVAL**

- A. Remove all manufactured washout containment facilities from the project area.
- B. For excavated pits, pump out and properly dispose of all remaining water, remove any hardened solids, and remove all plastic liner materials and fill pit area flush with surrounding ground.
- C. For above-grade containment facilities, pump out and properly dispose of all remaining water, remove any hardened solids, and remove all plastic liner materials and spread out earthen berms.

END OF SECTION

