

### 2024 Edition Revisions to the SUDAS Standard Specifications

To update your printed manual, print this packet. Then remove the old sheets and place the revised sheets in your manual. Some pages are completely new and do not replace an existing sheet. Also, some pages do not contain revisions, but are included due to changes on the other side or a change in the page number. **PLEASE READ CAREFULLY - PAY ATTENTION TO THE SECTION NUMBER!** Included shading to help distinguish between divisions. Questions can be directed to Beth Richards - [brich@iastate.edu](mailto:brich@iastate.edu). The current edition of the manual, with the latest revisions incorporated, can be found at [www.iowasudas.org](http://www.iowasudas.org).

Division	Section	pg #	Summary of Revision(s)
1	Manual introductory info		Updated the Contributors and Acknowledgments page. <i>Note - if you want to replace the small business card for the spine of your manual, you can print a copy from our website.</i>
	1020, 1.15, C	7	Clarified the release of bid security to unsuccessful bidders.
4	4020, 2.01, F, 1, d	5	Updated reference.
	4020, 3.05, B, 3	8	Modified joint opening requirements for gasketed storm sewer.
	4030, 1.08, B & C	2	Corrected minor errors.
	4050, 3.01, 3.03, 3.04, 3.05, & 3.06	13-22	Added "complete inspection according to Section 4060 and the following" to each subsection.
6	Table of Contents	iii	Updated Table of Contents based on changes made in Division 6.
	6010, 2.16, A & B	11	References should be to Section 4010 (not 4020).
	Figure 6010.515	2	Reprinted to have blank back with addition of new figure.
	Figure 6010.516 (new)	1-3	Developed a rectangular version of SW-506. (Will end with Figure 6010.521, sheet 1 on the back of sheet 3).
	7010, 1.08, I, 3	3	Removed "profilograph" from the includes item.
7	7010, 2.02, C, 3	7	Identified the combinations of cement types that can be used with fly ash and GGBFS.
	7010, 3.07	23-28	Updated pavement smoothness quality control to reflect Iowa DOT's change from profilograph to inertial profiler. Added non-destructive measurement specifications to determine the pavement thickness and thickness index. (Change resulted in two additional pages).
	7020, 1.08, I, 3	4	Removed "profilograph" from the includes item.
	7020, 3.05	11-15	Updated pavement smoothness quality control to reflect Iowa DOT's change from profilograph to inertial profiler.
	7021, 3.01, B	4	Clarified placement and opening temperatures.
	7040, 3.06, C	13	Fixed numbering.
	7091, 1.08, F and 2.01, C	2-3	Minor corrections.
8	8010, 2.01, B, 3, a, 1)	4	Clarified Schedule 80 PVC meets the heavy wall conduit requirement.
9	9040, 1.08, P, 2, c	7	Sentence was supposed to stop at product (not include "to the haul road").
	9060, 1.08, A	1-7	Developed bid item for residential chain link fence. (Affected pages that followed and resulted in an extra page).
	Figure 9060.101	1-2	Updated figure based on addition of residential chain link fence.
	9080, 1.08, C	2	Added the concrete for ground mounting of the safety rail to be included with the bid item.



## Contributors and Acknowledgments

In 2023, SUDAS staff held many meetings to accomplish the various revisions reflected in the 2024 versions of the SUDAS manuals. These revisions would not have been possible without the efforts of the SUDAS technical committee members. The SUDAS program's success is also due to the dedication of the district committees and Board of Directors. Keeping the SUDAS manuals current is an ongoing, cooperative effort, involving hundreds of people who volunteer their time and expertise. It is not possible to acknowledge each of these volunteers individually, but we appreciate them all.

### SUDAS Corporation Board of Directors, 2023

<u>Board Member</u>	<u>Government/Agency</u>	<u>Board Member</u>	<u>Government/Agency</u>
Jenifer Bates	Iowa DOT	Aaron Lincoln	City of Sergeant Bluffs
Phillip Burgmeier	City of Ottumwa	Donna Matulac	Iowa DOT
Nick Buse	Calhoun/Sac Counties	Brent Morlok	City of Bettendorf
*David Carney	City of Sioux City	Mark Mueller	City of Ankeny
David Carroll	Warren County	Sarah Okerlund	Iowa DOT
Pamela Cooksey	City of Des Moines	Greg Parker	Johnson County
Matt Cox	City of Council Bluffs	Mark Rahm	City of Mason City
Ken DeKeyser	Hall & Hall Engineers	John Rasmussen	Pottawattamie County
Matt Ferrier	Bolton & Menk, Inc.	Brian Schadt	City of Davenport
John Gade	Fox Engineering	Bob Schiesl	City of Dubuque
Paul Geilenfeldt	Marshall County	Larry Stevens	HR Green, Inc.
Daniel Harness	Iowa DOT	Casey Stickfort	Clayton County
Eric Johnsen	Iowa DOT	*Michelle Sweeney	AECOM
*John Joiner	City of Ames	Michael Thiel	Iowa DOT
Ron Knoche	City of Iowa City	Ryne Thornburg	Van Buren County
Jamie Knutson	City of Waterloo	Lee Tippe	City of Cedar Rapids
Randy Krauel	City of Carroll	Bob Tobin	Shoemaker & Haaland
Jeff Krist	City of Council Bluffs	Dave Vermillion	City of Council Bluffs
*Scott Larson	City of Coralville	Tom Vlach	City of Des Moines

<u>Advisory Member</u>	<u>Government/Agency</u>	<u>Advisory Member</u>	<u>Government/Agency</u>
Steve Klocke	Snyder & Associates	Tara Naber	Iowa DNR
Darwin Larson	APAI	Ron Otto	AGC of Iowa
Greg Mulder	ICPA		

<u>Staff</u>	<u>Position</u>
Paul Wiegand	Program Director (until 7/14/2023)
David Carney	Program Director (starting 8/21/2023)
Beth Richards	Program Coordinator

\* Denotes an officer



**1.14 OPENING OF PROPOSALS**

At the time and place set forth in the notice to bidders, proposals will be opened and read aloud. Proposals will be rejected if not accompanied by a bid security submitted in a separate, marked envelope. Submittals that do not include acknowledgement of each addendum to the contract documents will be rejected, except in those instances, in the opinion of the Engineer, where the addendum not acknowledged by a bidder will have no effect on the bid amount. Bid openings will be open to the public.

**1.15 LIMITATION ON WITHDRAWAL OF PROPOSALS AFTER OPENING OF PROPOSALS**

- A. A bidder shall not withdraw its proposal for period of up to 60 calendar days after the date designated for opening of proposals, or such other period of time specified in the Notice. However, in those projects involving special assessments, and confirmation by the District Court, no bidder shall withdraw its proposal for a period of 30 calendar days after the confirmation of the assessments by the Court.
- B. In the event a bidder desires to withdraw its proposal, it shall make request therefore in writing to the Engineer stating the reasons for such withdrawal.
- C. If requested, the bid security of unsuccessful bidders shall be promptly returned as soon as the successful bidder is determined or within 30 days, whichever is sooner.

END OF SECTION



**2.01 STORM SEWERS (Continued)****F. High Density Polyethylene Pipe (HDPE):**

1. Use pipe complying with the following:
  - a. AASHTO M 294, Type S corrugated exterior and smooth interior.
  - b. Minimum pipe stiffness at 5% deflection according to ASTM D 2412.
  - c. Integral bell and spigot joints with elastomeric seals complying with ASTM F 477.
  - d. Maximum 5% deflection of the average inside diameter by testing after installation according to [Section 4060, 3.04](#).
2. Use of this pipe material requires specific approval by the Engineer.

**G. Corrugated Metal Pipe (CMP):**

1. Use pipe complying with the following:
  - a. AASHTO M 36, Type I.
  - b. Zinc coating complying with AASHTO M 218.
  - c. Corrugated steel circular section with annular or helical corrugations.
  - d. Gage of pipe according to [Iowa DOT Standard Road Plan DR-104](#) or as specified in the contract documents.
  - e. Coupling bands with annular or helical corrugations to match pipe ends.
2. Use of this pipe material requires specific approval by the Engineer.

**H. Spiral Rib Pipe:**

1. Use pipe complying with the following:
  - a. ASTM A 760 Type 1R.
  - b. Corrugation profile of 3/4 inch by 3/4 inch by 7 1/2 inches.
  - c. Type 2 aluminized steel complying with ASTM A 929.
  - d. Minimum thickness of 0.064 inch. Use gage of pipe according to manufacturer's requirements.
  - e. Coupling bands complying with manufacturer's recommendations.
2. Use of this pipe material requires specific approval by the Engineer.

**I. Coated Corrugated Metal Pipe:**

1. Use in corrosive soil or effluent conditions, or where specified in the contract documents or required by the Engineer.
2. Comply with AASHTO M 274. Use gage of pipe according to [Iowa DOT Standard Road Plan DR-104](#) or as specified in the contract documents.
3. Use of this pipe material requires specific approval by the Engineer.

**J. Corrugated Metal Arch Pipe (CMAP):**

1. Use pipe complying with the following:
  - a. AASHTO M 36, Type II.
  - b. Zinc coating complying with AASHTO M 218.
  - c. Corrugated steel Type I pipe reformed into a pipe-arch having an approximately flat bottom.
  - d. Coupling bands with annular corrugations or helical corrugations to match pipe ends.
  - e. Gage of pipe according to [Iowa DOT Standard Road Plan DR-104](#).
2. Use of this pipe material requires specific approval by the Engineer.

**2.01 STORM SEWERS (Continued)****K. Spiral Rib Arch Pipe:**

1. Use pipe complying with the following:
  - a. ASTM A 760 Type IIR.
  - b. Corrugation profile of 3/4 inch by 3/4 inch by 7 1/2 inch.
  - c. Type 2 aluminized steel complying with ASTM A 929.
  - d. Minimum thickness of 0.064 inch. Use gage of pipe complying with manufacturer's requirements.
  - e. Coupling bands complying with the manufacturer's recommendations.
2. Use of this pipe material requires specific approval by the Engineer.

**L. Polypropylene Pipe:**

1. Comply with the following for 12 inch to 30 inch pipe:
  - a. Double walled pipe meeting ASTM F 2764.
  - b. Minimum pipe stiffness per ASTM D 2412, 46 psi.
  - c. Integral bell and spigot joint complying with ASTM D 3212 and ASTM F 477.
2. Comply with the following for 30 inch to 60 inch pipe:
  - a. Triple walled pipe meeting ASTM F 2764.
  - b. Minimum pipe stiffness per ASTM D 2412, 46 psi.
  - c. Integral bell and spigot joint complying with ASTM D 3212 and ASTM F 477.
3. Use of this pipe material requires specific approval by the Engineer.

**M. Bituminous Joint Primer:** Material intended for use in priming concrete joints. Comply with the requirements of ASTM D 41.

**N. Engineering Fabric:** Comply with [Iowa DOT Article 4196.01](#).

**O. Non-Shrink Grout:** Comply with [Iowa DOT Materials I.M. 491.13](#).

**2.02 LINEAR TRENCH DRAIN**

Comply with approved manufacturer's requirements and [Iowa DOT Materials I.M. 449 \(MAPLE\)](#), as well as complying with [Figure 6010.521](#). Provide certification indicating continuous trench drain meets AASHTO M 306 for 40,000 pound proof load.

**2.03 CASING PIPE**

Comply with [Section 3020, 2.02](#) for casing pipe requirements.

**2.04 PIPE APRONS**

Comply with the requirements of Section 4020, 2.01 and [Section 4030, 2.01](#) for the pipe material of which the apron is constructed. Supply concrete pipe aprons according to [Figure 4030.222](#) and [Figure 4030.223](#). Supply CMP pipe aprons according to [Figure 4030.225](#).

**2.05 APRON FOOTINGS**

Comply with the requirements of [Section 6010](#) for reinforcing steel and structural concrete used in apron footings.

**2.06 APRON GUARD**

Use smooth or deformed steel bars, ASTM A 615, Grade 40 or Grade 60, or merchant quality, in the construction of the apron guard. Hot dip galvanize the apron guard according to ASTM A 123.



**PART 3 - EXECUTION****3.01 EXAMINATION**

- A. Verify measurements at site; make necessary field measurements to accurately determine pipe makeup lengths or closures.
- B. Examine site conditions to ensure construction operations do not pose hazards to adjacent structures or facilities.

**3.02 PIPE INSTALLATION****A. General:**

- 1. Clean pipe interior and joints prior to lowering into trench. Keep pipe clean during construction.
- 2. Begin at the lowest point in the line. Lay groove or bell end pointing upstream unless otherwise specified.
- 3. Place pipe with lifting holes at the top of the pipe and fill lift hole with non-shrink grout or manufactured plugs.
- 4. Assemble joints as specified by the pipe manufacturer.
- 5. Use a saw to cut ends of pipe flush with inside wall of manholes, intakes, and structures. Do not use hammer or other means to break pipe.
- 6. Provide manholes and intakes as specified in the contract documents.
- 7. Use watertight stopper, plug, or other approved means to protect the exposed upstream ends of the pipe and prevent soil sediment from entering the storm sewer system.

**B. Trenched:**

- 1. Excavate trench and provide pipe bedding and backfill material as specified in [Section 3010](#).
- 2. Prepare trench bottom to design line and grade so that only minor movement of the pipe is necessary after installation.
- 3. Lay pipe to design line and grade. Set field grades to invert of pipe.
- 4. Provide uniform bearing for full pipe barrel length. Excavate bell holes as necessary for uniform support of pipe barrel on bedding material.
- 5. Do not lay pipe in water or on saturated soil or bedding, or allow water to rise in trench around pipe prior to placing backfill material.
- 6. Do not disturb installed pipe and bedding when using movable trench boxes and shields. Block or anchor pipe as necessary to prevent joint displacement.

**C. Trenchless:** Comply with [Section 3020](#).**3.03 STORM SEWER INSTALLED WITHIN A CASING PIPE**

Comply with [Section 3020, 3.04](#) for installation of storm sewer within casing pipe.

**3.04 LINEAR TRENCH DRAIN**

- A. Install according to the manufacturer's requirements and the contract documents.
- B. Use duct tape or wood block to prevent intrusion of concrete during installation and paving.
- C. Connect to existing intake or manhole according to [Section 6010, 3.05](#) or discharge to an open drainageway/ditch.

**3.05 PIPE JOINTING****A. General:**

- 1. Clean joint surfaces to remove soil or foreign material prior to jointing pipe.
- 2. Assemble joints according to pipe manufacturer's recommendations. Use equipment that does not apply damaging forces to pipe joints.

**B. Reinforced Concrete Pipe (RCP), Reinforced Concrete Arch Pipe (RCAP), and Reinforced Concrete Elliptical Pipe (RCEP):**

- 1. Comply with [Figure 4020.211](#) for pipe joint wrapping. Secure engineering fabric in place to prevent displacement while placing backfill material.
- 2. If a rubber O-ring or profile gasket is specified for RCP, coat the rubber gasket and joint with soap-based lubricant immediately prior to closing the joint.
- 3. Place pipe such that joint openings on the outside or inside of the pipe do not exceed 1/2 inch.

**C. Reinforced Concrete Low Head Pressure Pipe (RCLPP); Polyvinyl Chloride Pipe (PVC) and Corrugated PVC Pipe; Polypropylene Pipe; and High Density Polyethylene Pipe (HDPE):** Coat gasket and joint with soap-based lubricant immediately prior to closing the joint.**D. Corrugated Metal Pipe (CMP) and Corrugated Metal Arch Pipe (CMAP):** Lap coupling bands to form a tightly closed joint upon installation.**E. Connections between Dissimilar Pipes:**

- 1. Use manufactured adapters or couplings approved by the Engineer.
- 2. Where adapters or couplings are not available, the Engineer may authorize use of a concrete collar as shown in [Figure 4020.211](#).

**3.06 APRONS**

- A. Install pipe aprons where specified in the contract documents. Use the same installation methods as used on the pipe to which the apron is being attached. Dewater area as necessary to prevent installing the apron in water or on saturated soil or bedding. Do not allow water to rise around the apron prior to backfilling the area.
- B. Install apron footings where specified in the contract documents. Construct according to [Section 6010](#) and the contract documents. Dewater area as necessary to prevent installing the apron footing in water or on saturated soil or bedding. Do not allow water to rise around the apron footing prior to backfilling the area.

---

**PIPE CULVERTS****PART 1 - GENERAL****1.01 SECTION INCLUDES**

- A. Pipe Culverts
- B. Pipe Aprons and Beveled Ends
- C. Footings for Concrete Pipe Aprons
- D. Pipe Apron Guards

**1.02 DESCRIPTION OF WORK**

Construct pipe culverts, beveled ends, pipe aprons, and associated appurtenances.

**1.03 SUBMITTALS**

Comply with Division 1 - General Provisions and Covenants.

**1.04 SUBSTITUTIONS**

Comply with Division 1 - General Provisions and Covenants.

**1.05 DELIVERY, STORAGE, AND HANDLING**

Comply with Division 1 - General Provisions and Covenants.

**1.06 SCHEDULING AND CONFLICTS**

Comply with Division 1 - General Provisions and Covenants.

**1.07 SPECIAL REQUIREMENTS**

None.

**1.08 MEASUREMENT AND PAYMENT****A. Pipe Culverts:****1. Trenched:**

- a. **Measurement:** Each type and size of pipe installed in a trench will be measured in linear feet from end of pipe to end of pipe along the centerline of pipe, exclusive of aprons. Lengths of elbows and tees will be included in length of pipe measured.
- b. **Payment:** Payment will be made at the unit price of each type and size of pipe.
- c. **Includes:** Unit price includes, but is not limited to, trench excavation; dewatering; furnishing and installing pipe; furnishing, placing, and compacting bedding and backfill material; connectors; testing; and inspection.

**2. Trenchless:**

- a. **Measurement:** Each type and size of pipe installed by trenchless methods will be measured in linear feet along the centerline of the casing pipe.
- b. **Payment:** Payment will be made at the unit price for each type and size of pipe.
- c. **Includes:** Unit price includes, but is not limited to, furnishing and installing pipe; trenchless installation materials and equipment; pit excavation, dewatering, and placing and compacting backfill material; pipe connections; testing; and inspection.

**1.08 MEASUREMENT AND PAYMENT (Continued)****B. Pipe Aprons:**

1. **Measurement:** Each type and size of pipe apron will be counted.
2. **Payment:** Payment will be made at the unit price for each type and size of pipe apron.
3. **Includes:** Unit price includes, but is not limited to, trench excavation; dewatering; furnishing and installing the apron; furnishing, placing, and compacting bedding and backfill material; connectors; and other appurtenances.

**C. Footings for Concrete Pipe Aprons:**

1. **Measurement:** Each type and size of footing installed on a concrete pipe apron will be counted.
2. **Payment:** Payment will be made at the unit price for each type and size of footing.
3. **Includes:** Unit price includes, but is not limited to, excavation; dewatering; reinforcing steel; concrete; furnishing, placing and compacting bedding and backfill material.

**D. Pipe Apron Guards:**

1. **Measurement:** Each type and size of pipe apron guard will be counted.
2. **Payment:** Payment will be made at the unit price for each type and size of pipe apron guard.
3. **Includes:** Unit price includes, but is not limited to, furnishing and installing the apron guard and repairing any damage to the apron from the installation process.

**3.01 SEWER CLEANING AND INSPECTION FOR REHABILITATION (Continued)**

5. Maintain a log of time spent performing additional pipe cleaning on each line segment.

**E. Remove Protruding Service Connection:**

1. Grind or cut services that protrude more than 1/2 inch into the sewer main.
2. Utilize a remote grinding/cutting device specifically designed to remove concrete, vitrified clay, PVC, and other types of pipe materials.
3. Notify Engineer if ductile iron, steel, cast iron, or other non-typical service materials are encountered to review the ability and risks of removing the protruding services.
4. Grind or cut protruding service flush to the main sewer pipe without scouring or damaging the main sewer or service connection.
5. Notify the Engineer immediately if the sewer main or service pipe are not structurally sound.

**F. Post-Cleaning CCTV Inspection:** Complete inspection according to Section 4060 and the following.

1. Complete CCTV inspection of sewer upon completion of all sewer cleaning, obstruction removal, and protruding service removal activities.
2. Identify active and inactive service connections by the following:
  - a. Observe each service connection and identify active connections by active sewage flow or evidence of recent sewage flow.
  - b. If the status of the connection is inconclusive, run water down adjacent services to verify the location of each service.
  - c. Dye test connections if necessary to verify active status.
  - b. Accurately measure and log the location and clockwise position of all active service connections.

**G. Groundwater:** If significant groundwater infiltration is present, which could result in resin loss, resin contamination, reduction in CIPP thickness, or inadequate curing, notify the Engineer prior to installing CIPP liner.**H. Inspection Reporting:**

1. Provide a copy of the pre-cleaning and post-cleaning video inspections. Include on-screen continuous footage, pipe diameter, direction of viewing, manhole number, and street location reference in the recording. Affix labels to the recording media to include the name of the project, the date, and the location of the inspection.
2. Provide a written report of the inspections. Include true to scale drawings of all sewer defects and observation locations. Reference the time stamp on each line item entry on the written report.

**3.02 BYPASSING SEWAGE**

- A. Submit a bypassing plan to the Engineer for review.
- B. When sewer line flows exceed the values in Table 4050.04, or the depth recommended by the manufacturer of the sewer rehabilitation practice being implemented, reduce flows to acceptable levels.
  1. Plug the line at a point upstream of pipe to be rehabilitated if bypassing is required.
  2. Pump flow to a downstream point or adjacent system as directed by the Engineer.
    - a. Provide pump and bypass lines of adequate capacity to handle all flows.
    - b. Provide adequate reserve pumps on-site for emergency use and for storm flows.
- C. Rehabilitation and inspection work may be completed without bypassing in certain situations including low flow conditions, adequate upstream storage, use of a flow-through packer, or other situations approved by the Engineer. If proposed work will be completed without bypassing, have equipment and plan of action available to implement bypass pumping in the event the work is delayed or sewage levels in the upstream line are in danger of causing backups.

**Table 4050.04: Maximum Depth of Flow During Inspection, Testing, and Rehabilitation**

Main Diameter	CCTV Inspection	Joint Testing/Sealing
6" to 10"	20% of pipe diameter	25% of pipe diameter
12" to 24"	25% of pipe diameter	30% of pipe diameter
27" and up	30% of pipe diameter	35% of pipe diameter

**3.03 CIPP MAIN LINING****A. General:**

1. Clean, prepare, and inspect the repair point according to Section 4050, 3.01
2. Install liner according to the manufacturer's published recommendations, ASTM F 1216, and ASTM F 2019.

**B. Resin Impregnation:**

1. Vacuum impregnate tube with resin (wet-out) at manufacturer's plant under quality controlled conditions or on-site in mobile wet-out unit.
2. Fill all voids in the tube material, adding 5% to 10% excess resin to allow for migration of resin into the voids and cracks.

**C. Insertion:****1. General:**

- a. Perform pre-lining video inspection immediately prior to insertion of the wet-out tube.
- b. Insert the wet-out tube through an existing manhole or approved access.
- c. Ensure the tube is continuous between manholes with no joints. A single tube may span several manhole reaches as allowed by the equipment, properties of the CIPP, and time limits imposed by sewage flows to the host pipe.
- d. Insertion of CIPP indicates acceptance of the host pipe conditions and the suitability of the liner inserted into the host pipe. Repair any failure of CIPP liner due to inadequate cleaning, groundwater infiltration, or defects in the liner system at no additional cost to the Contracting Authority.

**3.03 CIPP MAIN LINING (Continued)****2. Inverted Heat-Cured Liner:**

- a. Prior to installation of the liner, place a temperature sensor on the bottom of the host pipe to monitor the temperature of the outside of the liner during the curing process. Place sensor at the termination point or location most distant from the heat source.
- b. Insert the wet-out tube into the inversion device or standpipe with the impermeable plastic liner on the outside of the tube.
- c. Turn back the end of the liner to form a cuff and secure the cuff to the inversion device or standpipe.
- d. Apply air pressure or hydrostatic head as required to invert the tube into the host pipe with the impermeable liner on the inside of the pipe.
- e. Apply lubricant directly to the tube or pour lubricant into the standpipe during the inversion process to reduce friction.
- f. Maintain and adjust pressure as necessary to invert the tube from the point of insertion to the point of termination and to hold the tube tight against the wall, producing dimples at service connections.

**3. Pull-In UV Light Cured Liner:**

- a. If CIPP manufacturer recommends the use of a sliding foil for the existing pipe conditions, provide sliding foil which covers the lower third to lower half of the pipe circumference. Pull sliding foil into place.
- b. Fold the wet-out liner in half and pull into place through an existing manhole. Monitor pulling speed and tension to avoid exceeding the manufacturer's recommendations.
- c. Pull 1 to 2 feet of excess liner into the termination manhole.
- d. If the product is sensitive to elongation, measure the overall elongation of the tube after pull-in. Ensure the elongation of the tube is less than 2% of the overall length of the segment specified by the manufacturer.
- e. Expand the resin-impregnated tube as necessary to hold the tube tight against the wall, producing dimples at service connections.
- f. Perform CCTV inspection of the inflated liner prior to initiating cure. Confirm alignment and fit prior to initiating cure. Make corrections as necessary to provide a finished liner free of wrinkles and defects.

**D. Curing:****1. Heat Cured:**

- a. Maintain consistent pressure, as recommended by the liner manufacturer, until curing is complete. Increase pressures to compensate for external ground water, if present.
- b. Cure liner using circulating heated water or steam. Ensure the temperature is sufficient to affect a cure in all sections of the pipe.
- c. Monitor and log the temperature from the sensor placed between the impregnated tube and the host pipe.
- d. Initial cure will occur during heat up and is achieved when exposed portions of the new pipe appear to be hard and sound and the temperature sensor indicates the liner has reached the temperature necessary to effect a cure in the resin.
- e. After initial cure is reached, raise the temperature to post-cure temperatures and hold for a period of time as recommended by the resin manufacturer.
- f. Cool the new pipe to a temperature of 100°F for water cure and 113°F for steam cure before relieving the internal pressure within the section.

**2. UV Light Cured:**

- a. Automatically record the time, rate of travel of the ultraviolet assembly, pressures, and amount of lamps in operation for each CIPP segment as documentation of correct curing of the fabric tube.
- b. Maintain consistent pressure, as recommended by the liner manufacturer, until curing is complete.

**3.03 CIPP MAIN LINING (Continued)**

- c. Draw the multi-lamp ultraviolet curing assembly through the pipe at a consistent, predetermined, speed that allows for cross-linking/polymerization of the CIPP resin.
- d. Adjust air pressure during curing as necessary to hold liner tight to the wall. Maintain pressure by adjustment of the outlet valve.
- e. Remove the temporary internal calibration hose installed by the manufacturer after curing is complete.

**E. CIPP End Seal Installation:**

1. **Hydrophilic Gasket Sleeve:** Install sleeve according to ASTM F 3240, sleeve manufacturer's published recommendations, and the following:
  - a. Do not install sleeve in host pipe more than 24 hours prior to CIPP lining.
  - b. Clean the first 6 inches of the main pipe to remove debris and visible grease deposits.
  - c. Install metal retaining clip at the leading edge of the sleeve. The metal clip may be held in place with adhesive tape if desired.
  - d. Install the sleeve in the main pipe so the leading edge is no more than 6 inches inside the end of the main pipe as measured from the manhole wall.
  - e. If the main pipe has a diameter of 18 inches or larger, utilize anchor screws to hold the sleeve in place.
2. **Expansion Band System:** Install system according to manufacturer's published recommendations and the following:
  - a. After installation of the CIPP liner, trim the end of the liner squarely a distance of 2 to 6 inches from the inside face of the manhole.
  - b. Clean the exposed face of the main pipe to remove debris and loose resin.
  - c. Slide the rubber gasket into the pipe, centering it over the end of the liner. Ensure one expansion band will seat against the liner and the other will seat against the main pipe.
  - d. Expand the expansion bands using a hydraulic expansion tool approved by the band manufacturer.

**F. Service Reinstatement:**

1. Do not leave sanitary service blocked for more than 24 hours.
2. Reinstatement active service lines from within the main with a CCTV camera and remote cutting tool. Do not reinstate inactive service connections.
3. Machine the opening to full size of the service connection opening area. Ensure the bottom of the liner opening and service line are flush.
4. Ensure the opening does not have pipe fragments or CIPP fragments that may obstruct flow or snag debris.
5. In the event that service reinstatement results in a liner opening greater than 100% of the service connection opening, or damage to the service connection occurs, install a CIPP service repair to cover the over-cut service connection at no additional cost to the Contracting Authority.
6. If service connection cannot be reinstated remotely and requires excavation complete according to the local plumbing code at no additional cost to Contracting Authority.



**3.03 CIPP MAIN LINING (Continued)**

**G. Inspection:** Complete inspection according to Section 4060 and the following.

1. Perform CCTV video inspection of completed CIPP lining, including observance of reinstated service connections. Provide copy of video inspection to Jurisdiction.
2. Ensure the tube is free of dry spots, lifts (spots cured away from the sewer), and delaminations. Remove and replace deficient sections.
3. If the CIPP does not fit tight against the original pipe at its termination point, seal the space between the pipes by filling with a resin mixture or hydrophilic seal compatible with the CIPP.

**3.04 CIPP POINT REPAIR**

**A. Preparation:** Clean, prepare, and inspect the repair point according to Section 4050, 3.01.

**B. Bypass Pumping:** Develop a plan for flow diversion or stoppage. Review with Engineer prior to initiating repair.

**C. Installation:**

1. Bypass mainline flow according to the submitted bypass plan.
2. Install CIPP point repair according to system manufacturer's published recommendations.
3. Wet-out the liner with the entire volume of resin recommended by the manufacturer.
4. Load the wet-out liner onto the packer and secure in place. Ensure the ends of the packer extend beyond the ends of the liner.
5. Pull the packer into position within the pipe. Verify position with CCTV observation.
6. Apply air pressure to the packer to expand the CIPP point repair liner against the host pipe.
7. Maintain consistent pressure for the duration of the curing period.

**D. Inspection:** Complete inspection according to Section 4060 and the following.

1. Perform CCTV video inspection of completed CIPP point repair. Provide copy of video inspection to Jurisdiction.
2. Ensure the tube is free of foreign inclusions, dry spots, pinholes, wrinkles greater than 2% of the pipe diameter, and delamination. Remove and replace deficient sections.

**3.05 CIPP SERVICE REPAIR**

**A. Preparation:**

1. Prior to installation of the system, clean and prepare the interior of the host and service pipe in according to the manufacturer's written instructions.
2. Remove all debris and obstructions.

**3.05 CIPP SERVICE REPAIR (Continued)**

3. Perform a post cleaning CCTV inspection in preparation for installation of the lining system.
4. If any obstructions, joint misalignments, broken or collapsed pipe, or other conditions are identified that will prohibit proper installation of the system, notify the Engineer immediately.

**B. Installation:**

1. Install CIPP service repair according to system manufacturer's published recommendations and to the length specified in the contract documents.
2. Bypass main line flow according to the submitted bypass plan. Coordinate installation with service owner to prevent service line flows.
3. Wet-out the entire liner, including lateral and mainline portions, using vacuum impregnation.
4. Load the lining system inside or on a pressure apparatus and move into position in the mainline pipe at the service connection.
5. Align and verify the position of liner and service line via CCTV prior to initiating installation.
6. Apply air pressure to invert or expand the resin impregnated CIPP into the lateral pipe and push the main-line portion of the system against the main pipe. Maintain pressure until the curing process is complete.
7. Apply heat or UV light as required by the manufacturer to properly cure the liner.
8. If liner is heat cured, follow manufacturer's recommendations for cool-down before relieving pressure.
9. If liner is ambient cured, maintain pressure according to the manufacturer's recommendations before relieving pressure.
10. Remove frayed ends of the system.

**C. Inspection and Documentation:** Complete inspection according to Section 4060 and the following.

1. Provide Jurisdiction with video documentation of pre-installation conditions and post-installation conditions showing the repair.
2. Ensure the finished CIPP service repair is free of any leakage and visual defects including foreign inclusions, dry spots, lifts, pinholes, major wrinkles, and delamination. Repair any defects that could affect the structural integrity of the system or allow leaks.
3. Maintain a written log of installation conditions according to system manufacturer's recommendations. At a minimum, include time of wet out, time and location of insertion, time of inflation, bladder pressure requirements, required cure time, actual cure time, and cool down duration.
4. Submit documentation of results for CIPP liner material to Jurisdiction.

**3.06 PRESSURE TESTING AND GROUTING OF SEWER JOINTS****A. General:**

1. Clean, prepare, and inspect the repair point according to Section 4050, 3.01
2. Complete sewer joint and service connection testing and grouting according to the grout supplier and equipment manufacturer's published recommendations, ASTM F 2304, and ASTM F 2454.

**B. Equipment:**

1. **Joint Testing Device:** Provide a joint testing device (packer), with means for introducing air under pressure into the void area created by the expanded ends of the packer against the host pipe and a means of continuously measuring, viewing, and recording the static pressure of the test medium and grout within the void area only. Provide packer constructed in a manner to allow a limited amount of sewage to flow through at all times.
2. **Service Connection Testing Device:** Provide a service connection testing device with inflatable mainline end elements and a service line grouting plug that creates a void area extending beyond the main connection. Use a service line grouting plug sized to match the diameter of the service being grouted with an effective sealing length of at least 18 inches, unless otherwise specified in the contract documents.
3. **Pumping Equipment:**
  - a. Provide positive displacement metering grout pump and hose delivery system capable of supplying a mixed volume of grout at a minimum of 3 gallons per minute and 30 gallons of uninterrupted flow within 10 minutes.
  - b. Ensure pump system has sufficient discharge pressure (in excess of system pressure losses and groundwater) to deliver grout volume to fill void space within the gel set time of the chemical grout.
4. **Grout Tanks:** When using non-soluble additives, ensure grout tanks have mechanical mixing devices to keep additives in suspension.
5. **Measuring Equipment:** Provide means of measuring and recording the volume of mixed grout pumped for each grouted joint or service connection.

**C. Control Tests:**

1. Prior to beginning testing and grouting, perform a demonstration test in an above ground 8 inch nominal diameter test cylinder suitable to contain the full length of the packer and sustain the void test pressure. For service line testing, provide an 8 inch test cylinder with 6 inch service tee to receive the lateral bladder.
2. Equip the test cylinder with a pressure gauge to monitor internal pressure and a release valve to exercise a controlled release of pressurized air from the void area to test the packer under both sound and leaking conditions.
  - a. With the void release valve closed, inflate the packer and air test the void at 7 to 10 psi. Ensure the observed void pressure at the test cylinder pressure gauge is within  $\pm 1/2$  psi of the test monitoring equipment.
  - b. Crack open the release valve to simulate a small leak. Ensure the pressure drop of the cylinder gauge is within  $\pm 1/2$  psi of the test monitoring equipment.

**3.06 PRESSURE TESTING AND GROUTING OF SEWER JOINTS (Continued)**

2. After entering each pipeline segment, but prior to commencement of joint testing, position the packer on a section of sound and clean sewer between two consecutive pipe joints and perform a pressure test. Pressurize packer to between 7 and 10 psi and hold for a period of 15 seconds with a pressure drop of less than 1.0 psi. Deflate packer and ensure that void pressure monitoring equipment drops  $\pm 1/2$  psi of initial reading.
3. If any of the control tests are unsuccessful, clean equipment of excess grout or make necessary repairs and retest.

**D. Sewer Main Joint Pressure Testing:**

1. Test joints at a target pressure equal to  $1/2$  psi per vertical foot of pipe depth plus 2 psi (not exceeding 10 psi).
2. Position the packer within the pipe so the packer straddles the pipe joint to be tested. Verify location via CCTV monitoring.
3. Expand the packer ends to isolate the joint from the remainder of the pipe and to create a void area between the pipe joint and testing device.
4. Pump air into void space until the pressure reaches the required test pressure.
5. Stop the flow of air into the void space and observe the void pressure for 15 seconds.
6. If the pressure is maintained with a drop of less than 1 psi, the joint will be considered as having passed the test.
7. If the pressure drops more than 1 psi during the test period, the joint will be considered as having failed and sealing will be required.
8. Deflate packer and verify the void pressure monitor drops to within  $\pm 1/2$  psi of 0 psi. Clean equipment if pressure fails to return to 0 psi.

**E. Service Line Pressure Testing:**

1. Test service lines at a target pressure equal to  $1/2$  psi per vertical foot of pipe depth plus 2 psi (not exceeding 10 psi).
2. Position the testing device within the line segment to straddle the service connection. Verify location via CCTV.
3. Align the service bladder with the service connection.
4. Apply air pressure to invert or inflate the bladder from the mainline assembly into the service pipe.
5. Expand the packer ends to isolate the section of the service connection to be tested.
6. Introduce air into the void area until a pressure equal to or up to 10% greater than the required test pressure is observed.
7. Stop the flow of air into the void space and observe the void pressure for 15 seconds.
8. If the pressure is maintained, with a pressure drop of less than 2 psi, the connection will be considered as having passed the test.

**3.06 PRESSURE TESTING AND GROUTING OF SEWER JOINTS (Continued)**

9. If the pressure drops more than 2 psi during the test period, the connection will be considered as having failed and sealing will be required.
10. Deflate packer and bladder and verify the void pressure monitor drops to within  $\pm 1/2$  psi of 0 psi. Clean equipment if pressure fails to return to 0 psi.

**F. Sewer Main Joint Sealing by Injection Grouting:** Perform joint sealing according to ASTM F 2304, equipment manufacturer, grout supplier, and the following:

1. Position packer over the faulty joint and expand packer ends, isolating the joint with a tight seal.
2. Pump two-part chemical sealant material into the ratio specified by the grout supplier.
3. Continue to pump grout, in stages if necessary, until "refusal" is achieved.
  - a. Refusal indicates the grout has flowed throughout the void, into the surrounding soil, forming a cohesive seal stopping further flow of grout.
  - b. Under pumping conditions, void pressure will slowly rise as grout is forced into the surrounding soil and begins to set. When void pressure spikes an additional 8 psi or more in a short pumping period of 1 to 5 seconds, the point of refusal is achieved.
  - c. If a quantity of grout equal to 1/2 gallon per inch diameter of pipe size is pumped without reaching the point of refusal, staging may be required. Staging is accomplished by repetitive cycles of pumping and curing until refusal is achieved. Notify Engineer for approval before staging is attempted.
  - d. If joint cannot be sealed by staging, abandon sealing operations at that joint and notify Engineer.
4. Upon reaching refusal, stop grout pumps and allow grout to cure for 30 to 40 seconds.
5. Deflate packer to break away the ring of gel formed in the void and move at least one packer length away from the joint in either direction.
6. Ensure pressure gauge reads zero pressure  $\pm 1/2$  psi. If gauge does not return to zero clean equipment.
7. Reposition packer over joint and retest at a pressure equal to the initial test pressure.
8. If joint fails pressure test, repeat grouting and pressure testing procedure until the joint is sealed or Engineer determines grout consumption is too high and continued attempts to seal joint are abandoned.
9. Remove residual sealing materials that extend into the pipe or restrict the flow. Ensure sealed joint surfaces are left flush with existing pipe surface. Remove residual grout material from manhole; do not allow grout to be flushed down the sewer.

**G. Service Connection Sealing by Injection Grouting:** Perform service sealing according to ASTM F 2454, equipment manufacturer, grout supplier, and the following requirements.

1. Pump two-part chemical sealant material at the ratio specified by the grout supplier.
2. Continue to pump grout, in stages if necessary, until refusal is achieved.
  - a. Under initial pumping conditions, the void pressure will slowly rise to a range of approximately 2 to 4 psi.
  - b. Continue pumping until there is a sudden increase to over 8 psi in a few seconds, indicating refusal.

**3.06 PRESSURE TESTING AND GROUTING OF SEWER JOINTS (Continued)**

- c. If a quantity of grout equal to 1 gallon per foot of service line bladder plus 3 gallons is pumped without reaching the point of refusal, staging may be required.
  - d. Stage grouting by pumping additional grout equivalent to 1 gallon plus 0.25 gallons per foot of bladder, waiting 1 full minute and retesting. Do not exceed two stages unless approved by Engineer
3. Upon reaching refusal, stop grout pumps and allow grout to cure for 1 full minute.
  4. Deflate service packer, re-inflate, and repeat service line pressure testing.
  5. If the service connection test fails, repeat injection grouting and pressure testing procedures until service is sealed or Engineer determines grout consumption is too high and continued attempts to seal service are abandoned.
  6. Confirm flow after sealing of each service. If a grout blockage exists, immediately clear the service of the blockage.
  7. A thin film of residual grout inside the service, which does not significantly impede flow, is a normal result of sealing and is not considered a blockage.

**H. Inspection and Reporting:** Comply with ASTM F 2304 Section 12.9 as noted below.

1. **Inspection:** Complete inspection according to Section 4060 and the following.
  - a. Perform CCTV observation and recording of initial pressure testing, sealing operations (if required), and final pressure testing (if required) for each joint or service.
  - b. Perform final CCTV video inspection of sewer main rehabilitated by injection grouting after all grouting work is completed. Provide copy of video to the Jurisdiction.
2. **Reporting:** Upon completion of each pipe segment, submit a report showing the following information for each joint and service connection tested, grouted or both.
  - a. Identification of sewer pipe section tested.
  - b. Type of pipe material, diameter, and depth of pipe to surface at manholes.
  - c. Length of pipe sections between joints.
  - d. Test pressure used before and after sealing and duration of test.
  - e. Location of each joint or service connection tested and any joints or service connections not tested with and explanation for not testing.
  - f. Pass/fail results for each joint or service connection tested.
  - g. Volume of grout material used on each joint or service connection.
  - h. Grout mix record of the batches mixed including amount of grout and catalyst, additives, temperature of the grout solution in the tanks, and gel set time used.

**3.07 SPOT REPAIRS BY PIPE REPLACEMENT**

- A. Excavate trench according to [Section 3010](#).
- B. Remove existing pipe to the extent required and disconnect affected sewer services.
- C. Install replacement pipe of the same nominal size as the existing pipe.
  1. Use the materials as specified in the contract documents that comply with [Section 4010](#).
  2. Place bedding material according to [Section 3010](#).

<b>Section 6010 - Structures for Sanitary and Storm Sewers (Continued)</b>	<b>Figure No.</b>
Double Grate Intake with Manhole	6010.506
Single Open-throat Curb Intake, Small Box	6010.507
Single Open-throat Curb Intake, Large Box	6010.508
Double Open-throat Curb Intake, Small Box	6010.509
Double Open-throat Curb Intake, Large Box	6010.510
Rectangular Area Intake	6010.511
Circular Area Intake	6010.512
Open-sided Area Intake	6010.513
Boxouts for Grate Intakes	6010.514
Triple Rectangular Area Intake	6010.515
Large Well Double Grate Intake with Manhole	6010.516
Linear Trench Drain	6010.521
Open-throat Curb Intake Under Pavement	6010.541
Extension Unit for Open-throat Curb Intake Under Pavement	6010.542
Single Open-throat Curb Intake with Extended Opening	6010.545
Castings for Sanitary Sewer Manholes	6010.601
Castings for Storm Sewer Manholes	6010.602
Castings for Grate Intakes	6010.603
Castings for Area Intakes	6010.604

<b>Section 6020 - Rehabilitation of Existing Manholes</b>	<b>Page No.</b>
---	-----------------

<b>Part 1 - General</b>	
-------------------------	--

1.01	Section Includes	1
1.02	Description of Work	1
1.03	Submittals	1
1.04	Substitutions	1
1.05	Delivery, Storage, and Handling	1
1.06	Scheduling and Conflicts	1
1.07	Special Requirements	1
1.08	Measurement and Payment	1

<b>Section 6020 - Rehabilitation of Existing Manholes (Continued)</b>		<b>Page No.</b>
<b>Part 2 - Products</b>		
2.01	Infiltration Barrier	3
2.02	In-situ Manhole Replacement, Cast-in-place Concrete	3
2.03	Centrifugally Cast Cementitious Mortar Liner with Epoxy Seal	3
<b>Part 3 - Execution</b>		
3.01	Infiltration Barrier	5
3.02	In-situ Manhole Replacement, Cast-in-place Concrete	5
3.03	Centrifugally Cast Cementitious Mortar Liner with Epoxy Seal	6
3.04	Cleaning, Inspection, and Testing	6
<b>Section 6030 - Cleaning, Inspection, and Testing of Structures</b>		<b>Page No.</b>
<b>Part 1 - General</b>		
1.01	Section Includes	1
1.02	Description of Work	1
1.03	Submittals	1
1.04	Substitutions	1
1.05	Delivery, Storage, and Handling	1
1.06	Scheduling and Conflicts	1
1.07	Special Requirements	1
1.08	Measurement and Payment	1
<b>Part 2 - Products</b>		
	None.	
<b>Part 3 - Execution</b>		
3.01	Cleaning	2
3.02	Visual Inspection	2
3.03	Repair	2
3.04	Sanitary Sewer Manhole Testing	2
3.05	Test Failure	4



**2.15 CASTING ANCHOR BOLTS AND WASHERS**

- A. Material:** Stainless steel or hot-dipped galvanized.
- B. Diameter:** Provide bolts and washers 1/8 inch smaller than hole or slot in the casting frame, but no less than 1/2 inch diameter.
- C. Bolt Length:** As required to pass through adjustment rings and into manhole or intake structure to embedment depth recommended by anchor manufacturer.

**2.16 DROP CONNECTION****A. Internal:**

- 1. Receiving Bowl:** Marine grade fiberglass meeting ASTM D 790, ASTM D 638, and ASTM D 2583 with non-magnetic stainless steel anchor bolts meeting the manufacturer's recommendation.
- 2. Flexible Coupler:** Provide flexible couple matching the size of the receiving bowl and the drop pipe.
- 3. Drop Pipe and Bottom Elbow:** Provide drop pipe an equivalent diameter of the influent pipe. Limit pipe size to maintain space available for maintenance activities. Provide solid wall SDR 35 PVC pipe and elbow complying with [Section 4010, 2.01, A](#) or Schedule 40 PVC pipe and elbow complying with ASTM D 1785.
- 4. Pipe Brackets:** ASTM A 240, Type 304 or Type 316 stainless steel with stainless steel nuts and bolts.

**B. External:**

- 1. Pipe and Fittings:** Comply with [Section 4010, 2.01, G](#) for ductile iron pipe and fittings.
- 2. Concrete Encasement:** Comply with [Section 7010, 2.02](#).
- 3. Embedment Material:** Comply with [Section 3010, 2.02, A](#) or [2.06](#) for backfill material from the top of the elbow to the bottom of the sewer main.

**2.17 EXCAVATION AND BACKFILL MATERIAL**

Comply with [Section 3010](#) for bedding and backfill materials.

**PART 3 - EXECUTION****3.01 GENERAL REQUIREMENTS FOR INSTALLATION OF MANHOLES AND INTAKES**

- A. Excavation:** Excavate according to [Section 3010](#).
- B. Subgrade Preparation:**
- 1. Cut Sections (Undisturbed Soil):** Prepare subgrade to accurate elevation required to place subbase.
  - 2. Fill Sections:** Compact to 95% of maximum Standard Proctor Density and hand grade to accurate elevation required to place subbase, or install stabilization material as directed by the Engineer.
  - 3. Unstable Soil:** Install stabilization material as directed by the Engineer.
- C. Subbase:** Install 8 inch thick pad of Class I bedding material a minimum of 12 inches outside footprint of the structure.
- D. Installation of Manhole or Intake Structure:** When necessary, adjust wall height and depth of base to provide a minimum of 48 inches between form grade elevation and top of base. Form walls and construction joints for cast-in-place intakes or install precast intake boxes to ensure intake lids are set to match the longitudinal slope of the adjacent street unless otherwise specified in the contract documents.
- 1. Cast-in-place:** Comply with Section 6010, 3.02.
  - 2. Precast:** Comply with Section 6010, 3.03.
- E. Pipes:** Install and bed pipes and connect to manhole or intake. Install pipe flush with inside wall of structure. Place bedding and pipe embedment material according to [Section 3010](#).
- 1. Cast-in-place Structures:**
    - a. Storm:** Form structure walls around pipe.
    - b. Sanitary:** Form or core circular opening and install flexible, watertight gasket according to Section 6010, 2.08. Keep void between pipe and manhole section free of debris and concrete.
  - 2. Precast Storm Sewer Manholes or Intakes:** If annular space between pipe and structure is less than 2 inches, fill with non-shrink grout. If annular space is 2 inches or greater, construct a concrete collar around the pipe according to Section 6010, 3.05.
  - 3. Precast Sanitary Sewer Manholes:** Connect to structure with flexible, watertight gasket according to Section 6010, 2.08. Keep void between pipe and manhole section free of debris and concrete.
  - 4. Sanitary Sewer Manholes on Existing Pipe:** Install waterstop according to Section 6010, 2.08.
- F. Joint Sealant:**
- 1. Sanitary Sewer Manholes:**
    - a.** Install rubber O-ring or profile gasket (precast structures).
    - b.** Apply bituminous jointing material or butyl sealant wrap to exterior of all sanitary sewer manhole joints.

- ① Provide two #4 hoop bars at all pipe openings.
- ② Cast-in-place base shown. If base is precast integral with walls, the footprint of the base is not required to extend beyond the outer edge of the walls.
- ③ 12 inch minimum wall height above all pipes.
- ④ If required by casting manufacturer, provide support beam under all frame joints. Modify structure walls as required to provide pocket for beam.

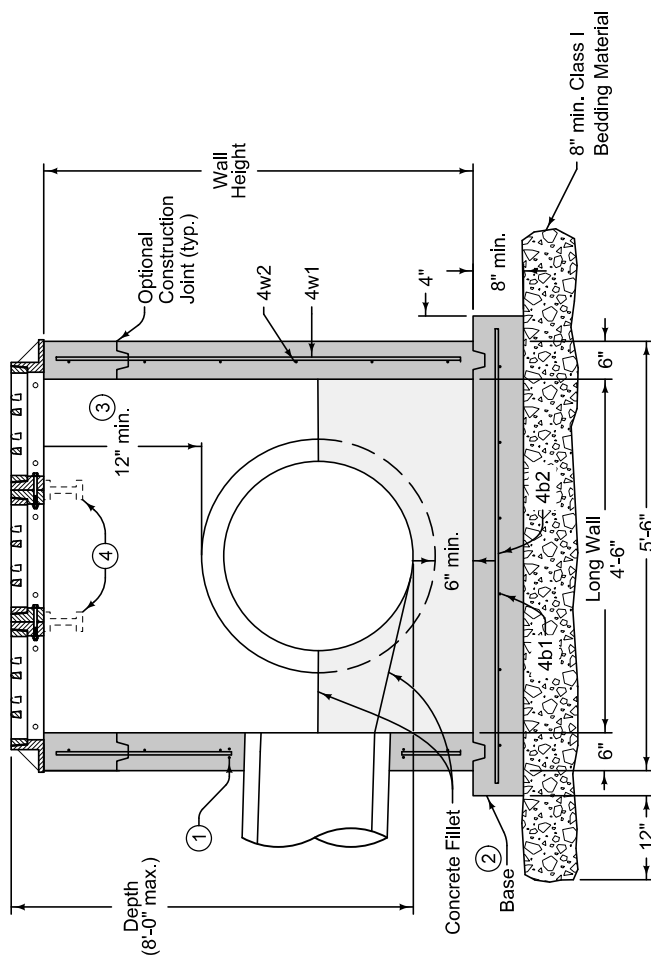

SECTION B-B

REINFORCING BAR LIST						
Mark	Size	Location	Shape	Count	Length	Spacing
4b1	4	Base	—	6	3'-6"	12"
4b2	4	Base	—	4	5'-8"	12"
4w1	4	Walls	—	20	Wall Height minus 4"	12"
4w2	4	Short Wall	—	Varies	3'-0"	12"
4w3	4	Long Wall	—	Varies	5'-2"	12"

MAXIMUM PIPE DIAMETERS		
Pipe Location	Precast Structure	Cast-in-place Structure
Short Wall	18"	21"
Long Wall	36"	42"

		REVISION New 04-21-20
		<b>SW-515</b> SHEET 2 of 2
<b>FIGURE 6010.515</b>	<b>STANDARD ROAD PLAN</b>	
REVISIONS: None.		
<i>Paul D. Weigand</i> SUDAS DIRECTOR DESIGN METHOD ENGINEER		
<b>TRIPLE RECTANGULAR AREA INTAKE</b>		



Maximum pipe diameters are set based on maximum structure depth of 6 feet-6 inches. Refer to SW-514 for boxout details.

- ① Install four #4 diagonal bars at manhole opening and at all pipe openings.
- ② Cast-in-place base shown. If base is precast integral with walls, the footprint of the base is not required to extend beyond the outer edge of the walls.

MAXIMUM PIPE DIAMETERS	
Wall	Max. Dia.
Front/Back	36"
Sides	42"

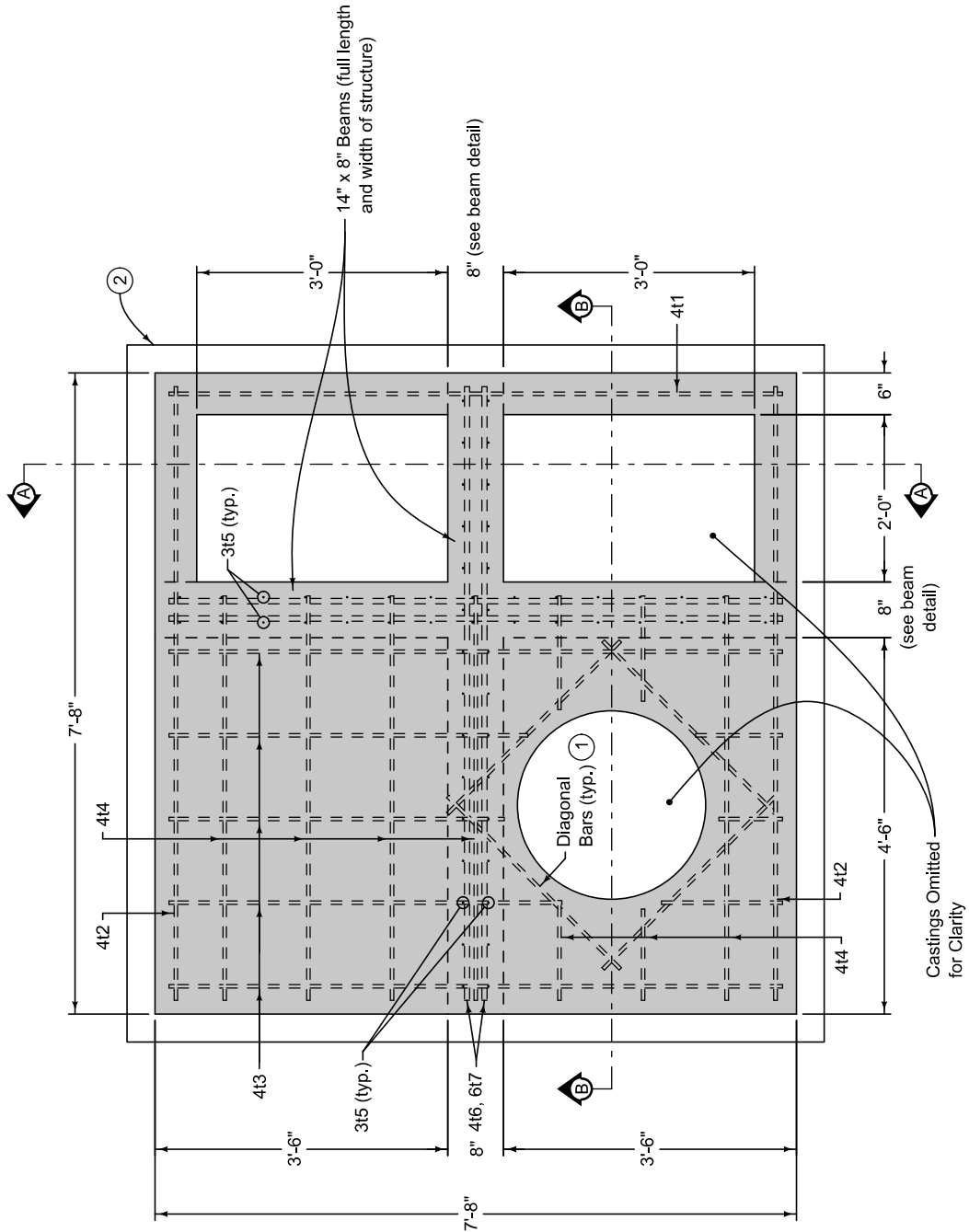

PLAN

Castings Omitted for Clarity

		REVISION New 4-16-24
		SHEET 1 of 3
FIGURE 6010.516	STANDARD ROAD PLAN	SW-516
REVISIONS: New		
DESIGN DIRECTOR		
DESIGN METHODS ENGINEER		
LARGE WELL DOUBLE GRATE INTAKE WITH MANHOLE		

- ① Install four #4 diagonal bars at manhole opening and at all pipe openings.
- ② Cast-in-place base shown. If base is precast integral with walls, the footprint of the base is not required to extend beyond the outer edge of the walls.
- ③ 12 inch minimum wall height above all pipes.
- ④ Form pockets in the wall to receive integral beams in the top.

**REINFORCING BAR LIST**

Mark	Size	Location	Shape	Count	Length	Spacing
4t1	4	Top	—	2	7'-4"	See Detail
4t2	4	Top	—	4	7'-4"	See Detail
4t3	4	Top	—	10	7'-4"	12"
4t4	4	Top	—	14	4'-2"	12"
3t5	3	Top	□	30	3'-1"	6"
4t6	4	Top	—	4	7'-4"	See Detail
6t7	6	Top	—	4	7'-4"	See Detail
4w1	4	Walls	—	Varies	7'-4"	12"
4w2	4	Walls	—	32	Wall Height minus 4"	12"
5b1	5	Base	—	9	7'-10"	12"
5b2	5	Base	—	9	7'-10"	12"

<b>SUDAS</b>	<b>IOWADOT</b>	REVISION New 4-16-24	<b>SW-516</b>
FIGURE 6010.516		REVISIONS: New	STANDARD ROAD PLAN
		SUDAS DIRECTOR	SHEET 2 of 3
		<i>Robert Miller</i> DESIGN METHODS ENGINEER	
<b>LARGE WELL DOUBLE GRATE INTAKE WITH MANHOLE</b>			

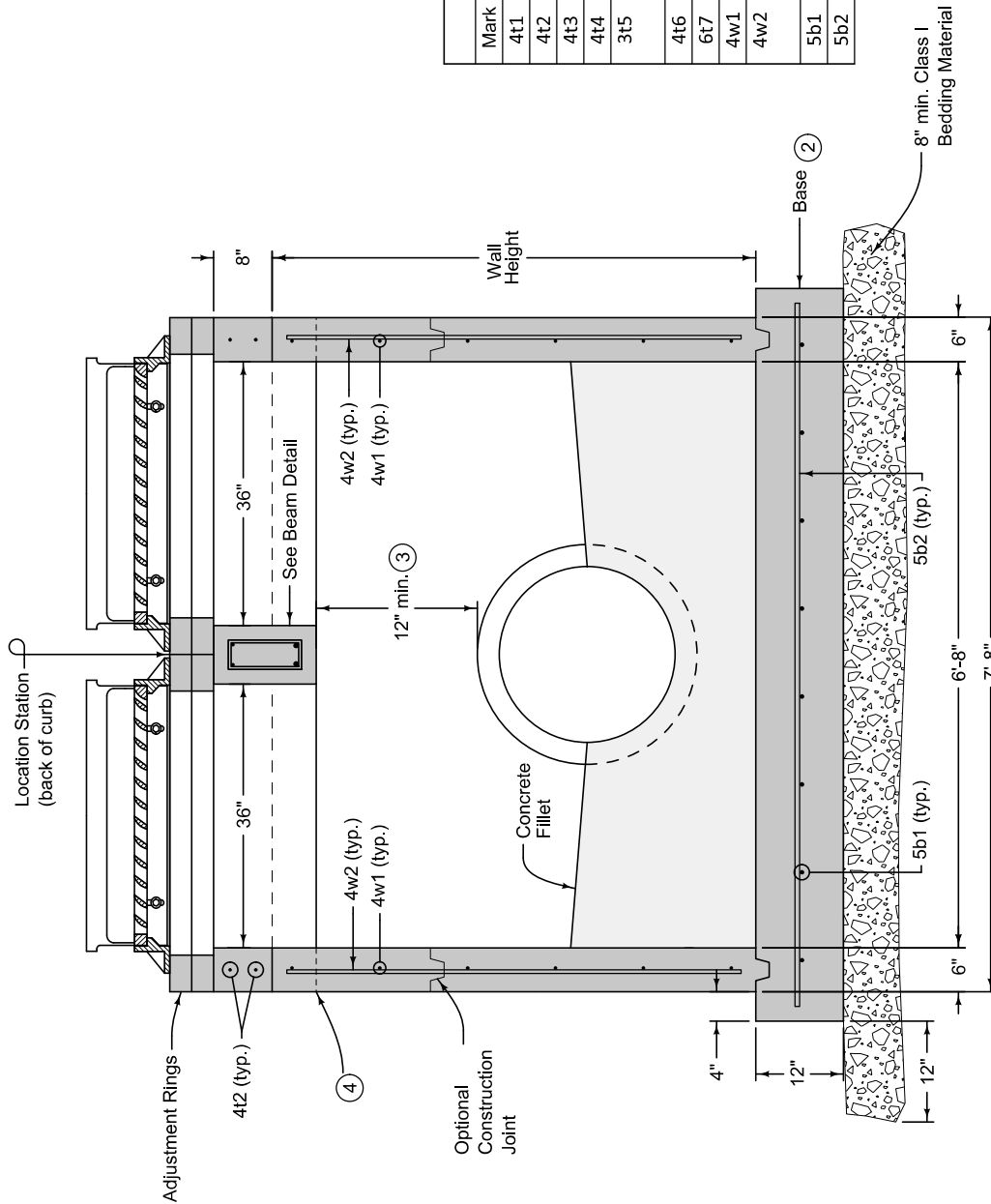

**SECTION A-A**

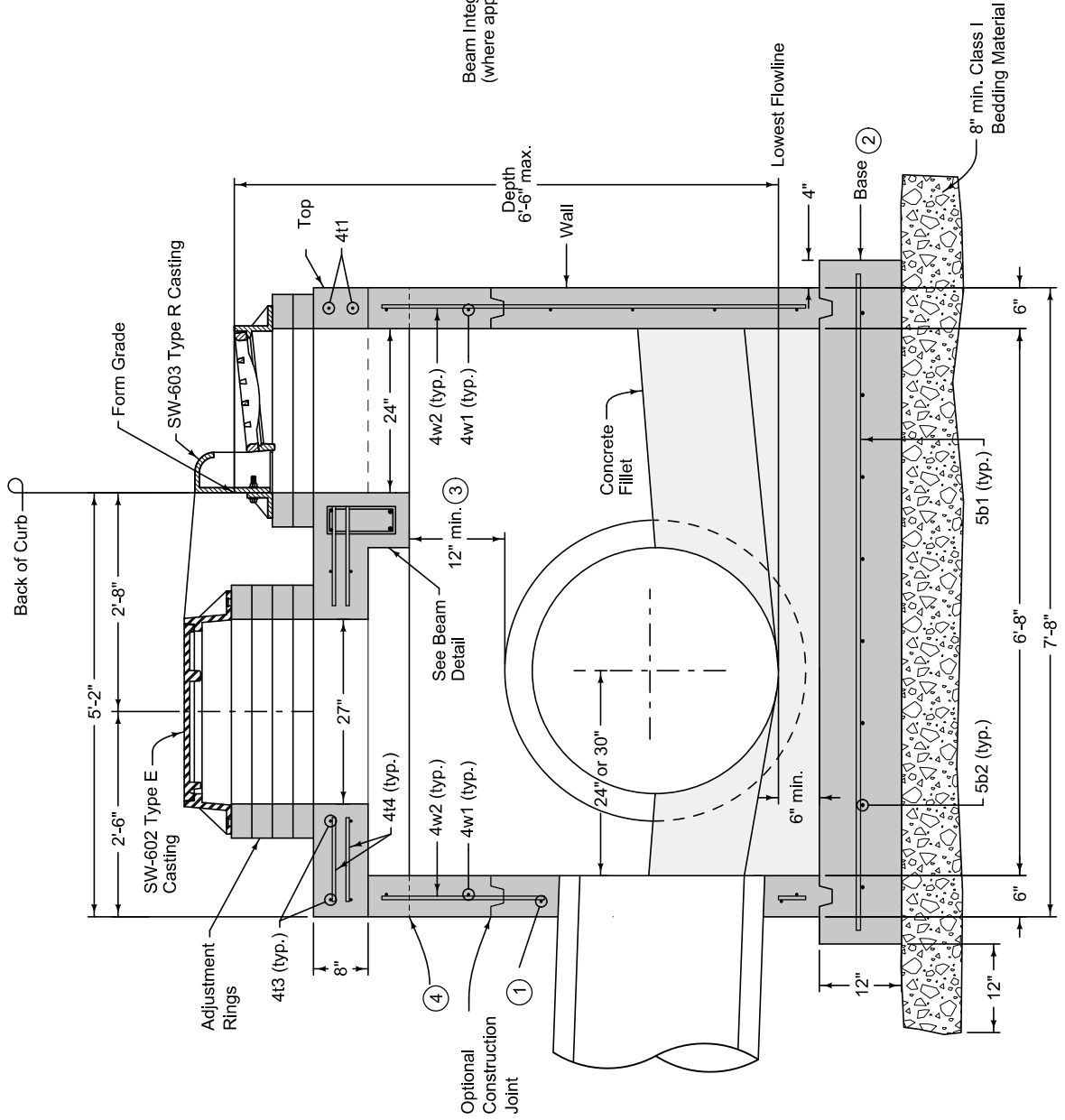

- ① Install four #4 diagonal bars at manhole opening and at all pipe openings.
- ② Cast-in-place base shown. If base is precast integral with walls, the footprint of the base is not required to extend beyond the outer edge of the walls.
- ③ 12 inch minimum wall height above all pipes.
- ④ Form pockets in the wall to receive integral beams in the top.

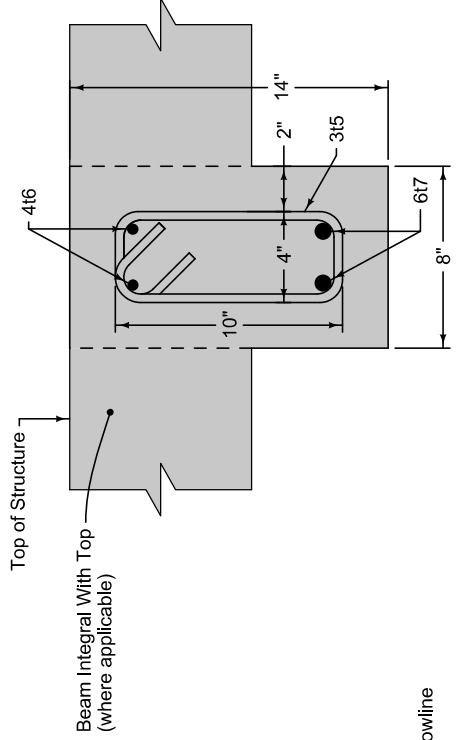

		REVISION
		New 4-16-24
		<b>SW-516</b>
		SHEET 3 of 3
REVISIONS:		
New		
<b>LARGE WELL DOUBLE GRATE INTAKE WITH MANHOLE</b>		

- ① 6 inches or same as thickness of adjacent pavement, whichever is greater.
- ② Linear Trench Drain.
- ③ For joint details, see PV-101.
- ④ Slope same as adjacent pavement.
- ⑤ Width as determined by manufacturer. Minimum 6 inches.

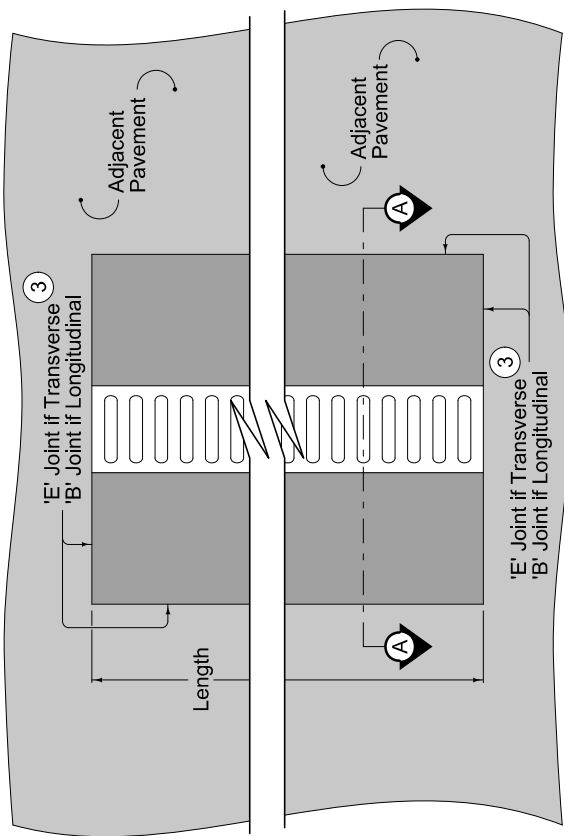

PLAN

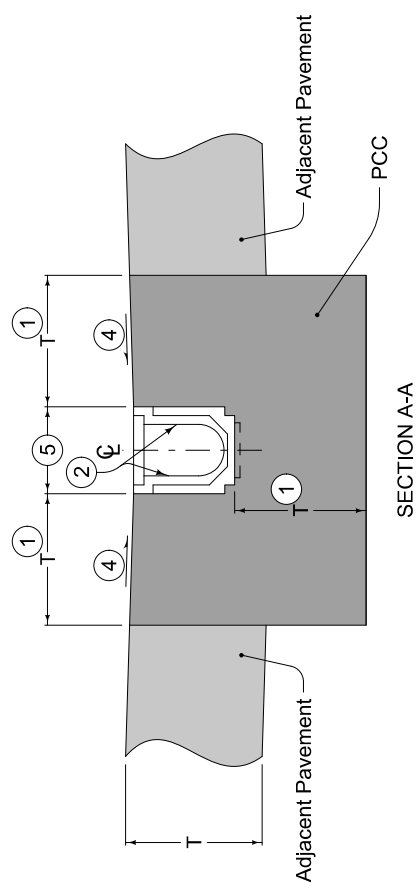

SECTION A-A

SUDAS IOWADOT	REVISION	2	04-21-20
	FIGURE 6010.521	STANDARD ROAD PLAN	
REVISIONS: Converted to joint standard. Modified circle note 1.		SHEET 1 of 2	
Brad D. Wigand SUDAS DIRECTOR		[Signature] DESIGN METHODS ENGINEER	
<b>LINEAR TRENCH DRAIN</b>			



**1.08 MEASUREMENT AND PAYMENT (Continued)****G. Concrete Median:**

1. **Measurement:** Measurement will be in square yards of concrete median. When the curb is integral with the pavement, the width will be measured from back of curb to back of curb.
2. **Payment:** Payment will be at the unit price per square yard of concrete median.
3. **Includes:** Unit price includes, but is not limited to, final subgrade/subbase preparation, bars and reinforcement, joints and sealing, surface curing and pavement protection, and boxouts for fixtures.

**H. PCC Railroad Crossing Approach:**

1. **Measurement:** Measurement will be in square yards of railroad crossing approach.
2. **Payment:** Payment will be at the unit price per square yard of railroad crossing approach.
3. **Includes:** Unit price includes, but is not limited to, excavation for modified subbase and subdrain, furnishing and installing subdrain, furnishing and installing subdrain outlet or connection to storm sewer, furnishing and installing porous backfill material, furnishing and placing modified subbase material, furnishing and installing reinforcing steel and tie bars, furnishing and placing concrete, furnishing, placing, and compacting asphalt.

**I. PCC Pavement Samples and Testing:**

1. **Measurement:** Lump sum item; no measurement will be made.
2. **Payment:** Payment will be at the lump sum price for PCC pavement samples and testing.
3. **Includes:** Lump sum price includes, but is not limited to, certified plant inspection, pavement thickness cores, pavement smoothness measurement (when required by the contract documents), and maturity testing.

**J. Granular Surfacing:** Comply with [Section 7030](#) for granular surfacing material placed at intersecting roads, driveways, and turnouts.

**K. PCC Pavement Widening:**

1. **Measurement:** Measurement will be in square yards for each different thickness of PCC pavement widening. The area of manholes, intakes, or other fixtures in the pavement will not be deducted from the measured pavement widening area.
2. **Payment:** Payment will be at the unit price per square yard for each thickness of PCC pavement widening.
3. **Includes:** Unit price includes, but is not limited to, final subgrade/subbase preparation, integral curb, bars and reinforcement, joints and sealing, surface curing and pavement protection, safety fencing, concrete for rigid headers, boxouts for fixtures, and pavement smoothness.

**L. Pavement Removal:** Comply with [Section 7040](#).

**M. Fixture Adjustment:** Comply with [Section 6010](#) for adjustment of manholes and intakes and [Section 5020](#) for adjustment of water valves and fire hydrants.

**PART 2 - PRODUCTS****2.01 MATERIALS**

**A. Cement:** Meet the requirements of [Iowa DOT Section 4101](#) and [Materials I.M. 401](#), including Type I and Type II cements and blended hydraulic cements Type 1P, Type 1S, Type 1T, and Type 1L.

**B. Supplementary Cementitious Materials (SCM):**

- Fly Ash:** Comply with [Iowa DOT Section 4108](#).
- Ground Granulated Blast Furnace Slag (GGBFS):** Comply with [Iowa DOT Section 4108](#).
- Limestone:** Comply with [Iowa DOT Materials I.M. 401](#).

**C. Fine Aggregate for Concrete:**

- Meet the requirements of [Iowa DOT Section 4110](#) and [Materials I.M. 409](#), Source Approvals for Aggregates.
- Comply with the following gradation:

Sieve Size	Percent Passing
3/8"	100
No. 4	90 to 100
No. 8	70 to 100
No. 30	10 to 60
No. 200	0 to 1.5
<a href="#">Iowa DOT Article 4109.02, Gradation No. 1 in the Aggregate Gradation Table.</a>	

- The Engineer may authorize a change in gradation, subject to materials available locally at the time of construction.

**D. Coarse Aggregate for Concrete:**

- Crushed stone particles with Class 2 durability complying with [Iowa DOT Section 4115](#) and [Materials I.M. 409](#), Source Approvals for Aggregates.
- Comply with one of the following gradations:

Sieve Size	Gradation No. 3 Percent Passing	Gradation No. 4 Percent Passing	Gradation No. 5 Percent Passing
1 1/2"	100	100	-----
1"	95 to 100	50 to 100	100
3/4"	-----	30 to 100	90 to 100
1/2"	25 to 60	20 to 75	-----
3/8"	-----	5 to 55	20 to 55
No. 4	0 to 10	0 to 10	0 to 10
No. 8	0 to 5	0 to 5	0 to 5
No. 200	0 to 1.5	0 to 1.5	0 to 1.5
<a href="#">Iowa DOT Article 4109.02, Gradation No. 3, 4, and 5 in the Aggregate Gradation Table.</a>			

- The Engineer may authorize a change in gradation, subject to materials available locally at the time of construction.

**2.02 CONCRETE MIXES (Continued)****C. Use of Fly Ash and Ground Granulated Blast Furnace Slag (GGBFS) as Supplementary Cementitious Materials:**

1. Mix proportions for the various mixes using fly ash and GGBFS are included in [Iowa DOT Materials I.M. 529](#). The maximum allowable fly ash substitution rate is 20%. Do not use a GGBFS substitution rate of more than 35% by weight (mass). The total supplementary cementitious material substitution rate is not to exceed 40%.
2. If C-SUD or CV-SUD mixes are specified, the maximum allowable Class F fly ash substitution rate is 25% and the maximum Class C fly ash substitution rate is 35%. The maximum combination rate is 20% Class C fly ash and 20% GGBFS.
3. When Type IP, IT, or IS cement is used in the concrete mixture, only fly ash substitution will be allowed. Between October 16 and March 15, use of Type IL cement with fly ash and GGBFS or Type IP, IS, or IT cement with fly ash will be allowed only when maturity method is used to determine time of opening. Transport, store, haul, and batch fly ash and GGBFS in such a manner to keep it dry.

**PART 3 - EXECUTION****3.01 EQUIPMENT****A. Batching and Mixing Equipment:****1. General:**

- a. **Weighing and Proportioning Equipment:** Comply with [Iowa DOT Article 2001.20](#).
- b. **Mixing Equipment:** Comply with [Iowa DOT Article 2001.21](#).
- c. **Material Bins:** Involves any structure in which materials are stored. Each part of any bin, including foundations and supports, must be adequate to withstand any stress to which it might be subjected to while in use.

**2. Batching:**

- a. Ensure the batching plant is Iowa DOT calibrated and approved. Provide copy of current calibrations and approvals.
- b. Coordinate the batch plant operation and batch trucks with the paving operation in order to ensure a steady supply of materials.
- c. Operate the batch plant and trucks to minimize dust, noise, or truck nuisances.

**3. Mixing:****a. Construction or Stationary Mixer:**

- 1) Ensure the concrete is uniform in composition and consistency. If this condition is not produced because of the size of the batch, the size of the batch may be reduced or the mixing time increased, or both, until this result is obtained. If non-uniform, corrective action must be taken.
- 2) Ensure the methods of delivering and handling the concrete are such that objectionable segregation or damage to the concrete will not occur, and they will facilitate placing with a minimum of handling.

**b. Ready Mixed Concrete:**

- 1) Ensure the concrete is uniform in composition and consistency. If non-uniform, concrete producers must take corrective action.
- 2) Ready mixed concrete is defined as concrete proportioned in a central plant and mixed in a stationary mixer for transportation in trucks without agitation, proportioned at a central plant, and only partially mixed in a stationary mixer for transportation and finish mixing in a transit mixer, or proportioned at a central plant, and then mixed in a transit mixer prior to or during transit.
- 3) When necessary to add additional mixing water at the site of placement, mix the batch at least an additional 30 revolutions of the drum at mixing speed.
- 4) Ensure each vehicle in which concrete will be delivered is capable of discharging concrete having a slump not over 2 inches at an overall rate for its entire load of not less than 1.25 cubic yards per minute. Ensure the concrete is delivered at a rate sufficient to maintain a sustained rate of progress of not less than 100 feet per hour for the width and depth of pavement to be placed.

- c. **All Methods:** Identify each truck load by a plant charge ticket showing plant name, contractor, project data, quantity, class, time batched, and water added at site.

**B. Concrete Delivery Equipment:****1. General:**

- a. In handling concrete from the mixer to the place of deposit, take care to avoid segregation.
- b. When concrete is deposited through a chute, slope the chute to allow concrete to flow slowly without segregation. Place the delivery point of the chute as close as possible to the point of deposit. Keep chutes and spouts clean. Thoroughly flush them with water before and after each run. Discharge the water outside the paving area in an approved concrete washout area.

**3.07 QUALITY CONTROL**

- A. Testing:** Provide the following material certifications and testing required to be performed by Supplier or Contractor.

**Table 7010.02: Material Certifications and Testing**

Material or Construction Item	Tests	Applicable Standard <sup>1</sup>	Methods of Acceptance of Sampling and Testing	Field Sampling and Testing	
				Frequency (minimum)	Responsible Party
Fine Aggregates	Gradation	<a href="#">I.M. 302, 306, 336</a>	Cert. Plant Insp. <sup>2</sup>	1/250 CY or min 1/day	Supplier/ Contractor
	Moisture	<a href="#">I.M. 308, 527</a>	Cert. Plant Insp. <sup>2</sup>	1 per 1/2 day	
	Specific Gravity	<a href="#">I.M. 307</a>	Cert. Plant Insp. <sup>2</sup>	1/250 CY or min 1/day	
	Quality	<a href="#">I.M. 209</a>	Approved Source	Prior to use	
Coarse Aggregates	Gradation	<a href="#">I.M. 302, 306, 336</a>	Cert. Plant Insp. <sup>2</sup>	1/250 CY or min 1/day	
	Moisture	<a href="#">I.M. 308, 527</a>	Cert. Plant Insp. <sup>2</sup>	1 per 1/2 day	
	Specific Gravity	<a href="#">I.M. 307</a>	Cert. Plant Insp. <sup>2</sup>	1/250 CY or min 1/day	
	Quality	<a href="#">I.M. 209</a>	Approved Source	Prior to use	
Portland Cement	Quality	<a href="#">I.M. 401</a>	Approved Source	Prior to use	
Fly Ash	Quality	<a href="#">I.M. 491.17</a>	Approved Source	Prior to use	
GGBFS	Quality	<a href="#">I.M. 491.14</a>	Approved Source	Prior to use	
Curing Compound	Quality	<a href="#">Iowa DOT Section 4105</a>	Approved Source	Prior to use	
Joint Sealer	Quality	<a href="#">I.M. 436.01</a>	Approved Source	Prior to use	
Epoxy Dowel Bars and Assemblies	Quality	<a href="#">I.M. 451.03B</a>	Approved Source	Prior to use	
Tie Bars	Quality	<a href="#">I.M. 451</a>	Approved Source	Prior to use	
Plastic Concrete	Air Content	<a href="#">I.M. 318, 327</a>	Field Test	1/200 CY or min. 1/day	Engineer
	Slump	<a href="#">I.M. 317</a>	Field Test	1/200 CY or min. 1/day	
	Cylinders	<a href="#">I.M. 315</a>	Field Test	Set of 3/500 CY or two sets/day	
	Beams	<a href="#">I.M. 316, 327, 328</a>	Field Test	Set of 3/500 CY or two sets/day	
	Thickness	-----	Field Test	1/200 CY	
Hardened Concrete	Smoothness	SUDAS 7010, 3.07	Field Test - Straightedge	Project length	Contractor
	Smoothness	SUDAS 7010, 3.07	Field Test - Inertial Profiler	Project length	
	Thickness	SUDAS 7010, 3.07	Field Test	1 core/1000 SY or 3 cores/project	
	Strength	<a href="#">I.M. 383</a>	Maturity Tests <sup>3</sup>	Prior to placement	

<sup>1</sup> Refers to the Iowa DOT Materials I.M.s, Iowa DOT Standard Specifications, or SUDAS Standard Specifications.

<sup>2</sup> Certified plant inspection per [Iowa DOT Materials I.M. 527](#).

<sup>3</sup> The Contractor is responsible for developing the maturity curve for the specified mix, taking maturity readings, and delivering a copy of the results to the Engineer.

**3.07 QUALITY CONTROL (Continued)****B. Air Content:**

1. Air content of the concrete will be evaluated according to [Iowa DOT Materials I.M. 318](#) and [327](#).
2. When a test result is outside the tolerance for the target air content, the contractor will be notified immediately. An air test will then be immediately run behind the paver to aid in identifying the limits of the non-complying air. A test result between 5% and 8% behind the paver will be considered complying. This test will represent all concrete from the back of the paver back to the last documented complying test. Make immediate adjustments to the mix production and placement process to bring the air content back within tolerance. Do not use succeeding loads below the lower target air content tolerance by more than 0.5%. Each subsequent load will be tested until air content is within tolerance for two consecutive loads. For all incorporated, non-complying concrete that is out of tolerance, the Engineer will determine if removal and replacement is required or if a price adjustment, according to Table 7010.03, will be applied.

**Table 7010.03: Concrete Air Content Price Adjustments**

Air Content Range			% Payment of Unit Price
Minimum		Maximum	
1.1*	and	below	0%
0.6	to	1.0*	50%
0.1	to	0.5*	75%
	Low air tolerance limit		100%
	Target		100%
	High air tolerance limit		100%
0.1	to	0.5**	95%
0.6	to	1.0**	85%
1.1	to	1.5**	75%
1.6	to	2.0**	60%
2.1**	and	above	0%

\*Air content deviation below the acceptable limits

\*\* Air content deviation above the acceptable limits

**C. Pavement Smoothness:** Evaluate pavement smoothness for all PCC pavement and overlay surfaces.

1. **Straightedge:** The Engineer will check PCC pavement surfaces with a 10 foot straightedge placed parallel to the centerline. Areas showing high spots of more than 1/4 of an inch in 10 feet will be marked. Complete surface corrections according to the following procedures to an elevation where the area or spot will not show surface deviations in excess of 1/8 inch when tested with a 10 foot straightedge.
  - a. Complete surface corrections by diamond grinding, placing a PCC overlay, or replacement.
  - b. Use grinding and texturing equipment complying with [Iowa DOT Section 2532](#). Use a minimum 36 inch wide cutting head, unless a 24 inch cutting head is necessary due space limitations.
  - c. Perform surface correction parallel to lane lines or edge lines as directed by the Engineer. Make each pass parallel to the previous pass. Ensure the ground surface is of a uniform texture.
  - d. Do not allow adjacent passes to overlap more than 1 inch or have a vertical difference of 1/8 inch as measured from bottom of groove to bottom of groove.

**3.07 QUALITY CONTROL (Continued)**

- e. Begin and end smoothness corrections at lines normal to the pavement lanes lines or edge lines within any one corrected area. Proceed from the centerline or lane line toward the pavement edge to maintain pavement cross slope.

Surface corrections will be completed at the direction of the Engineer with no additional cost to the Contracting Authority.

**2. Inertial Profilers:**

- a. If specified in the contract documents, comply with [Iowa DOT Section 2317](#) and [Materials I.M. 341, Appendix A](#) to measure pavement smoothness with an inertial profiler and start appropriate corrective measures, if necessary; the engineer will determine the corrective measures to be taken. No incentive for pavement smoothness will be made.
- b. Evaluate according to the smoothness requirements of Table 7010.04 and make surface corrections and/or price reductions. Surface corrections will be completed with no additional cost to the Contracting Authority. No incentive for pavement smoothness will be made.
- c. Smoothness measurements will be suspended for structures and through intersections.

**Table 7010.04: Smoothness Adjustment/Correction**

Segment Speed	Mean Roughness Index (inches per mile)	Pay Factor
Greater than 45 mph	< 200	100%
	200 to 250	-\$15.00/foot/lane or grind <sup>1</sup>
	≥ 250	Grind <sup>1</sup>
Less than or equal to 45 mph	< 250	100%
	250 to 300	-\$15.00/foot/lane or grind <sup>2</sup>
	≥ 300	Grind <sup>2</sup>

<sup>1</sup> Correct to below 200 inches per mile

<sup>2</sup> Correct to below 250 inches per mile

**D. Pavement Thickness:**

- At locations determined by the Engineer, cut samples from the pavement by drilling with a core bit that will provide samples with a 4 inch outside diameter. Restore the surface by tamping low slump concrete into the hole, finishing, and texturing. The Engineer will witness the core drilling, identify, and take possession of the cores. The Engineer will determine the core locations, measure the cores, and determine the thickness index according to [Iowa DOT Materials I.M. 346](#) and [347](#), except as modified as follows:
  - For regular or irregular shaped areas, use a lot size of 1,000 square yards. Include remnants less than 500 square yards in the last lot and remnants greater than 500 square yards in a separate lot. Take a minimum of three cores per project.
  - For any core with a deficiency greater than 0.15 inch, take two additional cores in that pavement lot and use the average of the three cores.
- If approved by the Engineer, take non-destructive measurements to determine the pavement thickness and the thickness index for each section.
  - Use Magnetic Imaging Tomography (MIT) Scan T2 or T3 gauge to perform thickness measurements.
  - Use 24 gauge commercial steel as targets that are 11.81 inches in diameter with G90 coating meeting ASTM A 653.

- c. The Engineer will determine the location of each lot, the random location of each metal target, and the random thickness measuring scheme for each section using an Iowa DOT developed spreadsheet. Immediately prior to paving, the Engineer will place the target or observe the contractor place the target. The program will randomly determine which targets to measure.
- 1) For regular or irregular areas, the section will be divided longitudinally into 1,000 square yard lots. One target will be located in each lot based on the spreadsheet selection. Beginning with the first station at +00, place a target from the edge of the pavement halfway between dowel baskets, if applicable. If the +00 station falls on a basket, move the target location ahead halfway between the dowel baskets. A minimum of 10 targets will be tested. If a target location falls on a bridge or in an approach section, it will be eliminated.
  - 2) The transverse location of the targets will be randomly determined by the spreadsheet. The random locations will be 4 feet from edge of pavement, left or right. Place targets in the center of the pavement panel to prevent interference by the steel in the joints. For ease of measuring, plates may be placed 18 inches from the edge if there is no tie steel or a work bridge is not available.
- d. Follow the manufacturer's instructions for operating the thickness gauge. It is important to avoid testing close to any steel including vehicles, equipment, steel toed shoes as well as tie bars, dowel bars and baskets, and manhole covers. When wearing steel toed shoes, always keep both toes at least 2 feet from the gauge during the test. Three repeat readings will be taken. The readings should all be within 0.15 inch of each other.
- e. Evaluate each section according to [Iowa DOT Materials I.M. 346](#).
- f. The Engineer will perform quality assurance testing at a minimum of one random test per seven plate locations, using one of the following methods.
- 1) Probe during paving operations according to [Iowa DOT Materials I.M. 396](#). Plates may be moved to 18 inches from the edge of the pavement to allow easier testing.
  - 2) Survey, to a minimum of 0.005 foot, on the plate prior to paving and on top of the pavement directly over the plate after placement to determine an accurate thickness verification.
  - 3) MIT gauge according to [Iowa DOT Materials I.M. 346](#). Use a different gauge than the one used by the contractor on the project.
- g. Include all MIT Scan measurements and quality assurance measurements for calculation of pavement thickness. The final pavement thickness will be determined by one of the following:
- 1) If all the quality assurance measurements are within  $\pm 0.25$  inch of the MIT Scan measurements, the MIT Scan measurements will be considered validated. The Engineer will determine final thickness based on the average MIT Scan measurements.
  - 2) If at any one location, the quality assurance measurements are greater than  $\pm 0.25$  inch difference from the MIT Scan measurements, core at the plate location and 2 feet away from the plate location. If the core at the plate location indicates that it has moved during placement, use the core thickness from the core taken 2 feet away as the pavement thickness. The Engineer will replace the MIT Scan thickness at the location with the core thickness taken 2 feet away along with the average MIT Scan measurements as final pavement thickness.
  - 3) If all of the quality assurance measurements are greater than  $\pm 0.25$  inch difference from the MIT Scan measurements, the Engineer will randomly select a minimum of 10 random locations, at 2 feet from the plate location, for coring by the Contractor. The Engineer will use the average core thickness, tested according to [Iowa DOT Materials I.M. 346](#), to determine final pavement thickness.



**3.07 QUALITY CONTROL (Continued)**

- h. If any measurement is deficient from T by 0.5 inch or more, the measurement should be rechecked to confirm the reading and the equipment. If the repeat measurement is also 0.5 inch or more below T, mark the location directly over the target. Drill a 4.0 inch diameter core at that location. If the core length confirms the pavement is deficient by 0.5 inch or more, drill a core 60 feet in each direction longitudinally at the same transverse location from the deficient core. Drilling will be continued at 60 feet intervals until a core is obtained that is not deficient. Interpolate between this core and the adjacent core to determine the limits of the deficient area. These additional cores are to be used to define the deficient area and will not be used in the thickness index calculation. When an obstruction, such as a bridge, intersection, previous work, etc., prevents drilling a core at the required 60 feet interval in either direction longitudinally, continue the balance of the distance on the other side of the obstruction.
3. Coring of pavement or other work for thickness determination may be waived by mutual agreement for sections of the same design thickness less than 2,500 square yards.
  4. Based on the thickness index determined by the Engineer, the pavement payment will be as shown in Tables 7010.05 and 7010.06.
  5. If the thickness index deficiency is greater than 0.51 for pavements thinner than 9 inches or 0.91 for pavements 9 inches or thicker, the Engineer will study the extent and severity of the deficiency of the pavement areas. The Engineer will require one of the following based on a review on the level of deficiency, the amount of the payment penalty, and the estimated reduction in the design life of the deficient pavement:
    - a. Removal and replacement of the deficient areas with pavement complying with the contract documents at no additional cost to the Contracting Authority.
    - b. Completion of an agreement that provides a combination of an extended guarantee period and payment penalty and allows the deficient pavement to be left in place.

**Table 7010.05: Pay Factor for PCC Pavement for Design Thickness less than 9"**

<b>Thickness Index Range</b>	<b>Percent Payment</b>
More than 0 to -0.15	100
-0.16 to -0.25	95
-0.26 to -0.50	85
-0.51 or less	As determined by the Engineer

**3.07 QUALITY CONTROL (Continued)****Table 7010.06: Pay Factor for PCC Pavement for Design Thickness 9" or Greater**

<b>Thickness Index Range</b>	<b>Percent Payment</b>
More than 0.00 to -0.15	100
-0.16 to -0.20	99
-0.21 to -0.25	98
-0.26 to -0.30	97
-0.31 to -0.35	96
-0.36 to -0.40	95
-0.41 to -0.45	94
-0.46 to -0.50	93
-0.51 to -0.55	92
-0.56 to -0.60	91
-0.61 to -0.65	90
-0.66 to -0.70	89
-0.71 to -0.75	88
-0.76 to -0.80	87
-0.81 to -0.85	86
-0.86 to -0.90	85
-0.91 or less	As determined by the Engineer

- E. Defects or Deficiencies:** Remove and replace or repair pavement containing excessive cracks, fractures, spalls, or other defects at no additional cost to the Contracting Authority. The method of replacement or repair will be determined by the Engineer.

END OF SECTION

**1.08 MEASUREMENT AND PAYMENT****A. Asphalt Pavement by Ton:**

1. **Measurement:** Measurement will be in tons for each different layer (surface, intermediate, base), aggregate size, and binder grade of asphalt pavement.
2. **Payment:** Payment will be at the unit price per ton for each different layer (surface, intermediate, base), aggregate size, and binder grade of asphalt pavement.
3. **Includes:** Unit price includes, but is not limited to, asphalt mix with asphalt binder, tack coats between layers, construction zone protection, and quality control.

**B. Asphalt Pavement by Square Yards:**

1. **Measurement:** Measurement will be in square yards for each different thickness and binder grade of asphalt pavement. The area of manholes, intakes, or other fixtures in the pavement will not be deducted from the measured pavement area.
2. **Payment:** Payment will be at the unit price per square yard for each different thickness and binder grade of asphalt pavement.
3. **Includes:** Unit price includes, but is not limited to, asphalt mix with asphalt binder, tack coats between layers, construction zone protection, and quality control.

**C. Asphalt Base Widening by Ton:**

1. **Measurement:** Measurement will be in tons for each different layer (surface, intermediate, base), aggregate size, and binder grade of asphalt base widening.
2. **Payment:** Payment will be at the unit price per ton for each different layer (surface, intermediate, base), aggregate size, and binder grade of asphalt base widening.
3. **Includes:** Unit price includes, but is not limited to, asphalt mix with asphalt binder, tack coat between layers, construction zone protection, and quality control.

**D. Asphalt Base Widening by Square Yard:**

1. **Measurement:** Measurement will be in square yards for each different thickness and binder grade of asphalt base widening. The area of manholes, intakes, or other fixtures in the pavement will not be deducted from the measured base widening area.
2. **Payment:** Payment will be at the unit price per square yard for each different thickness and binder grade of asphalt base widening.
3. **Includes:** Unit price includes, but is not limited to, asphalt mix with asphalt binder, tack coat between layers, construction zone protection, and quality control.

---

**1.08 MEASUREMENT AND PAYMENT (Continued)****E. Asphalt Railroad Crossing Approach:**

1. **Measurement:** Measurement will be in square yards of railroad crossing approach.
2. **Payment:** Payment will be at the unit price per square yard of railroad crossing approach.
3. **Includes:** Unit price includes but is not limited to excavation for modified subbase and subdrain, furnishing and installing subdrain, furnishing and installing subdrain outlet, furnishing and installing porous backfill material, furnishing and placing modified subbase material, furnishing and applying tack coat, furnishing, placing, and compacting asphalt.

**F. Density Deficiency:**

1. **Measurement:** Measurement will be in square yards for each different density of asphalt pavement subject to a unit price reduction for density deficiency according to Section 7020, 3.04.
2. **Payment:** Payment will be at the reduced unit price according to Table 7020.02 for each density of asphalt pavement. If there is a density deficiency on a privately contracted roadway project, the Jurisdiction ultimately accepting ownership of the roadway will receive the penalty payment prior to acceptance of the work.

**G. Asphalt Pavement Thickness Deficiency:**

1. **Measurement:** Measurement will be in square yards for each different thickness of asphalt pavement that has deficient pavement thickness as determined in Section 7020, 3.04.
2. **Payment:** Payment will be at the percentage of the unit price indicated in Table 7020.03 for each different thickness of asphalt pavement. If there is a pavement thickness deficiency on a privately contracted roadway project, the Jurisdiction ultimately accepting ownership of the roadway will receive the penalty payment prior to acceptance of the work.

**H. Asphalt Pavement Smoothness Deficiency:**

1. **Measurement:** Measurement will be in square yards for each different segment of asphalt pavement subject to a unit price reduction for pavement smoothness according to Section 7020, 3.05.
2. **Payment:** Payment will be at the reduced unit price according to Table 7020.04 for each segment of asphalt pavement. If there is a pavement smoothness deficiency on a privately contracted roadway project, the Jurisdiction ultimately accepting ownership of the roadway will receive the penalty payment prior to acceptance of the work.

**I. Asphalt Pavement Samples and Testing:**

1. **Measurement:** Lump sum item; no measurement will be made.
2. **Payment:** Payment will be at the lump sum price for asphalt pavement samples and testing.
3. **Includes:** Lump sum price includes, but is not limited to, certified plant inspection, pavement thickness cores, density analysis, pavement smoothness measurement (when required by the contract documents), and air void testing.

**3.05 PAVEMENT SMOOTHNESS**

**A. Straightedge:** The Engineer will check asphalt pavement surfaces with a 10 foot straightedge placed parallel to the centerline. Areas showing high spots of more than 1/4 of an inch in 10 feet will be marked. Complete surface corrections according to the following procedures to an elevation where the area or spot will not show surface deviations in excess of 1/8 inch when tested with a 10 foot straightedge.

1. Complete surface corrections by diamond grinding, placing an asphalt overlay per [Section 7021](#), replacing the area per [Section 7040](#), or inlaying the area.
2. For diamond grinding, perform the same work and use the same equipment as specified in [Section 7010, 3.07, C](#). After diamond grinding, cover the surface with a slurry seal complying with [Section 7070](#).
3. If the surface is corrected by overlay, replacement, or inlay, begin and end the surface correction with a transverse saw cut normal to the pavement lane lines or edge lines within any one area. Ensure the profile of the surface is smooth with no bumps or dips at the beginning or end of the correction. Correction must be a minimum of the entire lane width.

Surface corrections will be completed at the direction of the Engineer with no additional cost to the Contracting Authority.

**B. Inertial Profilers:**

1. If specified in the contract documents, comply with [Iowa DOT Section 2317](#) and [Materials I.M. 341, Appendix A](#) to measure pavement smoothness with an inertial profiler and start appropriate corrective measures, if necessary; the engineer will determine the corrective measures to be taken. No incentive for pavement smoothness will be made.
2. Evaluate according to the smoothness requirements of Table 7020.04 and make surface corrections and/or price reductions. Surface corrections will be completed with no additional cost to the Contracting Authority. No incentive for pavement smoothness will be made.
3. Smoothness measurements will be suspended for structures and through intersections.

**Table 7020.04: Smoothness Adjustment/Correction**

Segment Speed	Mean Roughness Index (inches per mile)	Pay Factor
Greater than 45 mph	< 200	100%
	200 to 250	-\$15.00/foot/lane or correct <sup>1</sup>
	≥ 250	Correct <sup>1</sup>
Less than or equal to 45 mph	< 250	100%
	250 to 300	-\$15.00/foot/lane or correct <sup>2</sup>
	≥ 300	Correct <sup>2</sup>

<sup>1</sup> Correct to below 200 inches per mile

<sup>2</sup> Correct to below 250 inches per mile

**3.06 QUALITY CONTROL**

- A. Provide Quality Management - Asphalt (QM-A) for bid items with asphalt quantities exceeding 1,000 tons. On locally let projects, all testing normally conducted by the Iowa DOT may be performed by the Jurisdiction or an independent testing laboratory hired by the Jurisdiction.
1. General: Follow the procedures and meet the criteria established in [Iowa DOT Article 2303.03, B; Section 2521](#); and [Materials I.M. 510](#) and [511](#). Percent within Limits (PWL) stipulations in these documents is not required.
  2. Mix Design - Job Mix Formula (JMF):
    - a. The Contractor is responsible for the JMF for each mixture.
    - b. Submit a completed JMF for approval to the materials lab designated by the Contracting Authority. Submit supporting documentation demonstrating the design process was followed and how the recommended JMF was determined. Include an economic evaluation when required according to [Iowa DOT Section 2303](#). Include trial and final proposed aggregate proportions and corresponding gyratory data. In addition, submit sufficient loose mixture and individual material samples for approval of the design if requested by the Engineer.
    - c. The person preparing the JMF must be Iowa DOT certified in bituminous mix design.
    - d. If the JMF is not satisfactory, submit another JMF for review. An approved JMF will be required prior to beginning plant production.
  3. Plant Production:
    - a. General:
      - 1) Perform sampling and testing to provide the quality control of the mixture during plant production. Certified Plant Inspection according to [Iowa DOT Section 2521](#) is required.
      - 2) Ensure personnel performing production quality control testing is Iowa DOT certified for the duties performed.
      - 3) Provide easy and safe access to the location in the plant where samples are taken.
      - 4) A "significant mix change" is defined as a single occurrence of an aggregate interchange of greater than 5%, a single occurrence of an asphalt content change greater than 0.2%, or any deletion or introduction of a new material into the mix.
    - b. Sampling and Testing:
      - 1) Sample and test asphalt binder to verify the quality of the binder grade. Take asphalt binder samples at random times as directed and witnessed by the Engineer according to [Iowa DOT Materials I.M. 204](#).
      - 2) Use cold feed or ignition oven gradation for aggregate gradation control to assure materials are being proportioned according to the specifications. Take aggregate samples at random times as directed and witnessed by the Engineer according to [Iowa DOT Materials I.M. 204](#). The Engineer will secure the samples according to [Iowa DOT Materials I.M. 205, Appendix A](#).
      - 3) Sample the hot asphalt mixture at random locations as directed and witnessed by the Engineer according to [Iowa DOT Materials I.M. 322](#). Secure the samples according to [Iowa DOT Materials I.M. 205, Appendix A](#).
      - 4) Assist the Engineer with material sampling for verification testing. When the Engineer provides notification that a sample is to be taken, obtain sample within 15 minutes.
      - 5) Each day's production of a mix design will be considered a lot.
        - a) When the anticipated quantity for the day is 2,000 tons or more, divide that day's production into four sublots, with the first subplot being the first 500 tons produced. The Engineer will divide the remaining anticipated quantity for the day into three equally sized sublots.

**3.06 QUALITY CONTROL (Continued)**

- b) When the anticipated quantity for the day is less than 2,000 tons, use the first 500 tons produced for the first daily subplot. The Engineer will establish 750 ton daily sublots for mix production exceeding the first 500 tons.
- 6) No more than four paired hot asphalt mixture samples will be required for acceptance of a lot.
- 7) Do not take paired samples from the first 100 tons of mix produced each day or the first 100 tons of mix following a significant mix change. When paving operations are staged so each day of placement is less than 100 tons for the entire production of a bid item, establish a sampling plan with the Engineer that includes a minimum of one sample per 2,500 tons.
- 8) Test the quality control sample of each production paired sample as follows:
  - a) Prepare and compact two gyratory specimens according to [Iowa DOT Materials I.M. 325G](#).
  - b) Determine the density for each specimen according to [Iowa DOT Materials I.M. 321](#). Average the results to determine sample density.
  - c) Use the field quality control laboratory compaction for field density control. The laboratory density for field control will be the bulk specific gravity of compacted mixture (Gmb) at Ndesign. Bulk specific gravity at Ndesign will be determined by compacting specimens to Nmax and back calculating the bulk specific gravity at Ndesign.
  - d) Determine the Theoretical Maximum Specific Gravity of the uncompacted mixture according to [Iowa DOT Materials I.M. 350](#) or other test methods recognized by AASHTO or ASTM.
  - e) Determine laboratory air voids for each sample according to [Iowa DOT Materials I.M. 501](#).
- 9) When liquid anti-strip additives are used, satisfy one of the following methods to regulate the quantity of additive:
  - a) Present certification that the equipment used to measure and blend the liquid anti-strip additive:
    - Meets the anti-strip supplier's recommended practice,
    - Is directly tied to the asphalt binder supply system, and
    - Has been calibrated to the equipment manufacturer's guidelines.
  - b) Test the binder to measure the quantity of liquid anti-strip additive in the binder for every 5,000 tons of asphalt production. Obtain the Engineer's approval for the supplier's test method prior to use of the test.
  - c) Run the test method in [Iowa DOT Materials I.M. 319](#) during production. If unable to certify or test for the presence and quality, run the test method in [Iowa DOT Materials I.M. 319](#) each 10,000 tons of production to measure the effectiveness of the additive. Ensure test results satisfy the minimum requirements of [Iowa DOT Article 2303.02, E](#).
- c. Production Control:
  - 1) After the JMF is established, the combined aggregate furnished for the project, the quantity of asphalt binder, and the laboratory air voids should consistently comply with the JMF, as target values. Control them within the production tolerance given in Table 7020.05.

**3.06 QUALITY CONTROL (Continued)****Table 7020.05 Production Tolerances**

Measured Characteristic	Target Value (%)	Specifications Tolerance (%) <sup>1</sup>
Cold feed gradation No. 4 (4.75 mm) and larger sieves	by JMF	± 7.0
Cold feed gradation No. 8 (2.36 mm)	by JMF	± 5.0
Cold feed gradation No. 30 (600 µm)	by JMF	± 4.0
Cold feed gradation No. 200 (75 µm)	by JMF	± 2.0 <sup>2</sup>
Daily asphalt binder content	by JMF	± 0.3
Field laboratory air voids - absolute deviation from target	0.0 <sup>3</sup>	<1.0 <sup>4</sup>

<sup>1</sup> Based on single test unless otherwise specified.

<sup>2</sup> Maintain the filler/bitumen ratio of the plant produced mixture between 0.6 and 1.4.

<sup>3</sup> Unless otherwise specified.

<sup>4</sup> Based on the moving average of four test values.

- 2) Control plant production so that the plant produced asphalt mixture will meet mixture design criteria (within the test tolerances given in Table 7020.05) for Air Voids at Ndesign gyrations of the gyratory compactor. Monitor the slope of the gyratory compaction curve of plant produced material. Slope variations in excess of ±0.40 of the mixture design gyratory compaction curve slope may indicate potential problems with uniformity of the mixture.
- 3) The gyratory mix design gradation control points for the size mixture designated in the project plans will not apply to plant production control.
- 4) Strive for the target value of the percent air void and asphalt binder by adjusting gradation and asphalt binder content.
- 5) Produce a uniform composition mixture complying with the JMF.
- 6) Adjustments to the JMF target gradation and asphalt binder content values may be made.
  - a) Determine from quality control testing that adjustments are necessary to achieve the specified properties.
  - b) Consult with the Engineer regarding adjustments to the JMF.
  - c) The Contractor's adjustment recommendations prevail, provided all specifications and established mix criteria are being met for plant production.
- 7) Measure estimated film thickness and voids in the mineral aggregate (VMA) for specifications compliance every day of asphalt production.
- 8) Prepare quality control charts according to [Iowa DOT Materials I.M. 511](#). Keep the charts current and available showing both individual sample results and moving average values. Base moving average values on four consecutive sample results. Moving averages may restart only in the event of a mandatory plant shutdown for failure to maintain the average within the production tolerance. Include the target value and specifications tolerances on control charts.
- 9) Calculate laboratory voids for individual samples according to [Iowa DOT Materials I.M. 501](#). Use the individual density and individual maximum specific gravity determined for each sample. To determine the moving average of laboratory voids, use the average of the last four individual sample laboratory voids.
- 10) Monitor the test results and make mix adjustments, when appropriate, to keep the mixture near the target values. Notify the Engineer whenever the process approaches a specification tolerance limit. Cease operations when the moving average point for laboratory air voids is outside the specification tolerance limit. Assume responsibility to cease operations, including not incorporating material which has not been placed. Do not start the process again until notifying the Engineer of the corrective action proposed.



**3.06 QUALITY CONTROL (Continued)**

- B. Provide quality control for bid items with asphalt quantities of 1,000 tons or less as follows:
1. **Mix Design:** Prepare the job mix formula. Prior to asphalt production, obtain the Engineer's approval for the job mix formula. Comply with [Iowa DOT Article 2303.02](#) and [Iowa DOT Materials I.M. 510](#). Submit for approval.
  2. **Plant Production:** Use a current calibration of the asphalt production plant for the job mix formula no more than 12 months old. Maintain an asphalt binder log to track when the binder was delivered. Identify the job mix formula on the asphalt delivery ticket. Use certified asphalt binder and approved aggregate sources meeting the job mix formula. Monitor the quality control test results and make adjustments to keep the mixture near the target job mix formula values.
  3. **Construction:** Take density measurements of the compacted mixture. Use the field quality control laboratory compaction for field density control as specified in Section 7020, 3.04. The Engineer may accept the density of the compacted layer based on cores or density gauge. The Engineer may waive density measurement provided the compaction has been thorough and effective. Take density measurements of the compacted mixture no later than the next working day following placement and compaction. For small quantities, a lot is the entire quantity of each asphalt mixture bid item. The quality index for density will not apply to small quantities.
  4. **Sampling and Testing:** Material sampling and testing is for production quality control only. Acceptance of mixture is based on Contractor certification. Perform a minimum of one aggregate cold-feed and one loose asphalt test per lot. Sampling and testing of loose asphalt is only required for mechanically placed mixture. All sampling and testing procedures will follow the Iowa DOT Specifications and Materials I.M.s using certified technicians and qualified testing equipment. The Engineer may approve alternative sampling procedures, or may approve sampling of uncompacted mix and gradation if Contractor can provide plant reports for other recent projects(s) demonstrating the job mix formula has been produced according to the specifications. Take the sample between the first 100 to 200 tons of production. No split samples for agency correlation testing are required. Asphalt binder will be accepted based on the asphalt supplier's shipment certification. No binder sampling or testing is required. No material sampling or testing is required for daily asphalt production of less than 100 tons on any project.
  5. **Certification:** Provide a certification for the production of any mixture in which the requirements in this section for small quantities are applied. Place the test results and certification statement on the Iowa DOT Daily Plant Report. The Daily Plant Report for certified asphalt may be submitted at the end of the project for all certified asphalt quantities, or submitted at intervals for portions of the certified quantity. Use the following certification statement:

"The certified asphalt was produced in compliance with the provisions of Section 7020, of the SUDAS Standard Specifications. The certified asphalt was produced with certified asphalt binder and approved aggregates as specified in the approved mix design."

**3.07 REMOVAL OF PAVEMENT**

Comply with [Section 7040](#).

END OF SECTION



**2.05 HIGH PERFORMANCE THIN LIFT (CONTINUED)****C. Gradation:**

<b>Sieve Size</b>	<b>Minimum Percent Passing</b>	<b>Maximum Percent Passing</b>
1 1/2"		
1"		
3/8"	91	100
No. 4		90
No. 8	27	63
No. 16		
No. 30		
No. 50		
No. 100		
No. 200	2	10

**2.06 NOMINAL AGGREGATE SIZE FOR ASPHALT OVERLAYS**

Nominal aggregate size dictates lift thickness. Minimum lift thickness should be at least 3 times the nominal maximum aggregate size to ensure aggregate can be aligned during compaction to achieve required density. Therefore, desired lift thickness can direct the decision on nominal aggregate size to use.

**PART 3 - EXECUTION****3.01 ASPHALT OVERLAY**

Comply with [Section 7020](#), [Iowa DOT Section 2303](#), [Section 7040](#), and the following:

**A. Preparation of Existing Pavement:**

1. Remove pavement by milling as required by the contract documents. Mill to the depth, cross-section, or profile specified.
2. Sweep existing pavement with approved broom. Provide dust control during brooming.
3. If milling is not required, correct irregularities in existing pavement cross slope with partial patching, full-depth patching, and leveling base coat prior to placing the overlay. Use base or intermediate course mixes to correct irregularities. Surface course thickness per plan.

**B. Special Requirements for Thin Lift Overlays and Asphalt Interlayer:**

1. Apply tack coat prior to placement of thin lift overlay and asphalt interlayer. Comply with [Section 7020](#).
2. Keep the production temperature of asphalt mixtures between 225°F and 335°F until placed on the grade.
3. Compact with static steel wheel roller.
4. Do not open to traffic until the entire mat has cooled below 150°F.

**3.02 PROTECTION FROM TRAFFIC**

Comply with [Section 7020, 3.03](#).

**3.03 DEFECTS OR DEFICIENCIES**

Comply with [Section 7020, 3.04](#).

**3.04 PAVEMENT SMOOTHNESS**

Comply with [Section 7020, 3.05](#).

**3.05 QUALITY CONTROL**

**A. General:** Comply with [Section 7020, 3.06](#).

**B. Special Requirements for Thin Lift Overlays and Asphalt Interlayer:**

1. Complete field voids for Class II compaction as defined in [Iowa DOT Section 2303](#).
2. Sample and test from windrow or hopper. Apply [Iowa DOT Article 2303.05, A, 3](#) for AAD acceptance. Air void target is based on approved JMF.
3. Take at least one cold feed each day for gradation control.

**3.06 REMOVAL OF PAVEMENT**

Comply with [Section 7040](#).

END OF SECTION

**3.06 CRACK AND JOINT CLEANING AND FILLING, HOT POUR (Continued)**

2. Heat, handle, and apply joint filler material to the proper level as specified in the contract documents and as recommended by the manufacturer.
  - a. PCC Pavement: Do not overfill joint or crack with filler material. Immediately remove filler material placed on the pavement surface.
  - b. Asphalt Pavement: Slightly overfill the entire crack reservoir with filler material. Smooth with a narrow V-shaped squeegee immediately after placement of the filler material to within 1/2 inch on each side of the crack edge.
3. Place joint filler material when the pavement and ambient air temperatures are 40°F or higher. When near this minimum, additional air blasting or drying time, or both, may be necessary to ensure a satisfactory bond to the joint surfaces.
4. Lanes may be opened to traffic only after the filler material has set sufficiently so it will not pick up under traffic. Blotting material may be applied to the filler material, but only after the surface has set to avoid penetration of the blotting material into the filler material.

**3.07 CRACK CLEANING AND FILLING, EMULSION**

Use emulsified asphalt for filling cracks in asphalt surfaces only. Do not use on PCC pavements.

**A. General:**

1. Clean cracks with either high pressure air or water equipment. Do not use water when freezing temperatures exist or are forecasted.
2. Ensure vegetation is removed from cracks. Alternative cleaning methods may be necessary to remove vegetation.
3. When specified in the contract documents, apply a soil sterilant in crack prior to placing the filler material.
4. For filling cracks, use a hand operated wand or pouring pot, capable of placing the filler material into the crack and filling to the adjacent surface. Use a spout or nozzle small enough to place the filler material into the crack without soiling the adjacent surface.
5. Immediately after placement of the filler material, tightly spread the emulsion using a 2 inch, or less, V-shaped rubber-edged squeegee. Take proper measures to hold the filler in place and prevent runout at edge of pavement or at low areas.

**B. Cracks Wider Than 1 inch:**

1. Clean the cracks of loose and spalled material, sand, and other foreign debris to a depth of 3 inches using high pressure water.
2. When specified in the contract documents, utilize additional methods to clean cracks of old crack filler.
3. Blow the cleaned cracks free of water with high pressure air.
4. Lightly apply a tack coat to the crack surfaces.

**3.07 CRACK CLEANING AND FILLING, EMULSION (Continued)**

5. Fill the cracks with asphalt.
  - a. Ensure mix is warm and pliable when placed.
  - b. Rod and tamp the mix into place level with the adjacent surface.
  - c. Place mixture prior to filling cracks with emulsion.
6. Place a thin application of emulsion over the asphalt and tightly spread with a squeegee.

**C. Cracks 1/4 inch to 1 inch in Width:**

1. Clean the cracks of loose and spalled material, sand, and other foreign debris with high pressure air or high pressure water. Clean crack down to sound material, but a depth greater than 3 inches will not be required.
2. When specified in the contract documents, utilize additional methods to clean cracks of old crack filler.
3. Fill cracks with emulsion filler material.

**D. Cracks Less Than 1/4 inch in Width:**

1. Clean sufficiently to remove sand and other foreign debris.
2. Fill cracks with emulsion filler material.

**E. Map-cracked (Alligator) Areas:**

1. Cover area with emulsion filler material.
2. Spread emulsion over area with squeegee, working emulsion into cracks. Provide a thin, smooth application.
3. Promptly cover the filler material with a light application of blotter material.

**3.08 PAVEMENT REMOVAL**

- A. Saw full depth at pavement removal limits.
- B. Extend pavement removal limits to existing joint lines as directed by the Engineer.
- C. Protect existing pavement, beyond removal limits, from damage. Remove to a new saw line and replace, at no additional cost to the Contracting Authority, all concrete broken or damaged beyond the removal limits designated by the Engineer.

**3.09 CURB AND GUTTER REMOVAL**

- A. Saw longitudinally along the existing gutter joint or at a location directed by Engineer. Saw transversely at the curb and gutter removal limits.
- B. Remove existing curb and gutter without damaging the existing pavement to remain.

**FULL DEPTH RECLAMATION****PART 1 - GENERAL****1.01 SECTION INCLUDES**

Full depth reclamation of asphalt roadways

**1.02 DESCRIPTION OF WORK**

Includes pulverizing and mixing of existing asphalt and underlying materials; addition of stabilizing agents and additives if required; compaction of the reclaimed materials and curing of the compacted street.

**1.03 SUBMITTALS**

Comply with Division 1 - General Provisions and Covenants as well as the following:

- A. Prepare and submit the job mix formula to the Engineer for approval prior to initiating full reclaiming operations.
- B. Provide quality control test results.

**1.04 SUBSTITUTIONS**

Comply with Division 1 - General Provisions and Covenants.

**1.05 DELIVERY, STORAGE, AND HANDLING**

Comply with Division 1 - General Provisions and Covenants.

**1.06 SCHEDULING AND CONFLICTS**

Comply with Division 1 - General Provisions and Covenants.

**1.07 SPECIAL REQUIREMENTS**

None.

**1.08 MEASUREMENT AND PAYMENT****A. Full Depth Reclamation:**

1. **Measurement:** Measurement will be in square yards for the area of roadway reclaimed.
2. **Payment:** Payment will be at the unit price per square yard of roadway reclaimed.
3. **Includes:** Unit price includes, but is not limited to, pulverizing and sizing of existing asphalt layers; incorporating and mixing of existing underlying materials; protecting street fixtures; development of a job mix formula; adding and mixing stabilizing agents and additives, if required; compacting the reclaimed mix; shaping of the mix; removing any loose or excess material; curing; and final clean up.

**1.08 MEASUREMENT AND PAYMENT (Continued)****B. Mechanical Stabilization Agents:**

1. **Measurement:** Measurement will be in tons of aggregate.
2. **Payment:** Payment will be at the unit price per ton of aggregate.
3. **Includes:** Unit price includes, but is not limited to, furnishing and placing of aggregate and blending of the aggregates.

**C. Bituminous Stabilization Agents:**

1. **Measurement:** Measurement will be in gallons of asphalt emulsion or foamed asphalt furnished and incorporated.
2. **Payment:** Payment will be at the unit price per gallon of asphalt emulsion or foamed asphalt furnished and incorporated.
3. **Includes:** Unit price includes, but is not limited to, furnishing and placing of materials and mixing the agent into the reclaimed mix.

**D. Chemical Stabilization Agents:**

1. **Measurement:** Measurement will be in tons of chemical stabilization agents.
2. **Payment:** Payment will be at the unit price per ton of chemical stabilization agents.
3. **Includes:** Unit price includes, but is not limited to, furnishing and placing of materials and mixing the agent into the reclaimed mix.

**E. Microcracking**

1. **Measurement:** Measurement will be in square yards for the area of roadway microcracked.
2. **Payment:** Payment will be at the unit price per square yard of roadway microcracked.
3. **Includes:** Unit price includes, but is not limited to, furnishing equipment, protecting street fixtures, completing microcracking, and curing.

**F. Interlayer for Cement Stabilized Base**

1. **Measurement:** Measurement will be in square yards for each type and thickness of interlayer.
2. **Payment:** Payment will be at the unit price per square yard for each type and thickness of interlayer.
3. **Includes:** Unit price includes, but is not limited to, surface cleaning, furnishing, and placing of the interlayer.

**G. Fixture Adjustment:** Comply with [Section 6010](#) for adjustment of manholes and intakes and [Section 5020](#) for adjustment of water valves and fire hydrants.



**PART 2 - PRODUCTS****2.01 MATERIALS**

- A. Mechanical Stabilizing Agents:** Use virgin crushed aggregates, RAP, or crushed PCC in the gradation called for in the job mix formula.
- B. Bituminous Stabilizing Agent:** Use asphalt emulsion (HFMS-2s) meeting the requirements of [Iowa DOT Section 4140](#), or foamed asphalt using PG 52-34S asphalt binder meeting the requirements of [Iowa DOT Section 4137](#).
- C. Chemical Stabilizing Agent:**
1. Cement complying with [Iowa DOT Article 4101.01](#).
  2. Class C or Class F Fly Ash complying with [Iowa DOT Section 4108](#).
  3. Hydrated Lime complying with AASHTO M 216.
  4. Calcium Chloride complying with [Iowa DOT Section 4194](#).
  5. If approved by the Engineer, use proprietary products according to the manufacturer's requirements.
- D. Fog Seal Cure:** Comply with [Iowa DOT Section 2306](#).
- E. Water:** Comply with [Iowa DOT Section 4102](#). Potable water obtained from an approved supply does not need to be tested.
- F. Interlayer**
1. Class A crushed stone complying with [Iowa DOT Article 4120.04](#).
  2. HMA interlayer complying with [Section 7021, 2.04, B](#).

**2.02 JOB MIX FORMULA**

Compile a job mix formula using an analysis of the existing asphalt pavement layers and the subbase/subgrade and the required strength of the reclaimed pavement section as specified in the contract documents. The job mix formula will identify the stabilizing agent and any additives; the rates for the stabilizing agent and additive, if needed; and the rate of water to reach the optimum moisture content. Allowable tolerances should be included to allow the Contractor to adjust the mixture so that it is placed successfully.

**PART 3 - EXECUTION****3.01 EQUIPMENT****A. General:**

1. Perform full depth reclamation between April 1 and November 1.
2. Perform reclaiming operations when weather conditions are such that proper mixing, shaping, and compacting the reclaimed mix can be accomplished.

**B. Equipment:**

1. Furnish a self-propelled machine capable of reclaiming the existing paving material to the width and depth specified in the contract documents. Ensure the equipment meets the following:
  - a. Equipped with automatic depth control to maintain a constant depth and width.
  - b. Capable of pulverizing the existing roadway to the required gradation.
  - c. Accurately controls the rate of flow and total delivery of the stabilizing agent and additives, if needed, into the reclaimed mixture in relation to the speed and quantity of the material being recycled.
  - d. Capable of mixing the reclaimed material and any stabilizing agent and additive required by the job mix formula into a homogeneous mixture.
2. If specified in the contract documents, use an asphalt foaming system that accurately and uniformly adds the required percent of water to the hot asphalt binder. Use equipment fitted with a test nozzle to provide field samples of the foamed asphalt. Equip tankers supplying the hot asphalt binder with a thermometer to continuously monitor the temperature of the asphalt in the bottom third of the tank.
3. Have the following rollers available for use:
  - a. Sheepsfoot roller
  - b. Double drum steel roller (static and vibratory)
  - c. Pneumatic tire roller (25 ton or greater)
4. Provide a motor grader with grade and cross-slope control.

**3.02 PREPARATION**

Prior to initiating the reclaiming process, undertake the following tasks:

- A. Identify and protect all affected utilities.
- B. Remove excess dirt, vegetation, raised pavement markings, standing water, and any other objectionable materials.

**3.03 UTILITIES**

All utilities within the project limits should be protected prior to the pulverization. Locate and lower manholes, water valve boxes, and other fixtures a minimum of 4 inches below the bottom of the reclaimed section. Re-set manhole castings, water valves, and other fixtures to the proper elevations following completion of the compaction of the reclaimed mixture. If lowering of fixtures is not practical, excavate material from around the fixture to a location where it can be pulverized by the reclaimer. Move the pulverized material back around the fixture after mixing and compact with smaller compaction equipment to the required densities. Protect stormwater intakes by preventing reclaimed material from entering the drainage system.

**PART 2 - PRODUCTS****2.01 UNDERGROUND****A. Handhole:****1. General:**

- a. **Cable Hooks:** Unless otherwise specified, provide four galvanized steel cable hooks with a minimum diameter of 3/8 inch and a minimum length of 5 inches.
- b. **Granular Base:** Comply with the following gradations; however, the Engineer may authorize a change in gradation, subject to materials available locally at the time of construction.

Sieve	Percent Passing
2"	100
1 1/2"	80 to 90
1"	15 to 20
3/4"	0 to 0.5

- c. **Cover:** Include "TRAFFIC SIGNAL" as a message on the cover. Alternate messages may be required as specified in the contract documents.

**2. Precast Concrete Handhole:**

- a. **Pipe:** Comply with ASTM C 76. Minimum Class III, Wall B (Iowa DOT Class 2000D). Four, 8 inch knockouts (conduit entrance points) equally spaced around the handhole.
- b. **Casting:** Gray cast iron and certified according to requirements of AASHTO M 306 for a 16,000 pound proof-load (HS-20).

**3. Composite Handhole and Cover:** Composed of mortar consisting of sand, gravel, and polyester resin reinforced by a woven glass fiber mat or of resin mortar and fiberglass. Ensure the handhole and cover has a minimum ANSI/SCTE 77 2017 Tier 15 rating. Provide a skid resistant surface on the cover. Provide two 3/8-16 UNC stainless steel hex head bolts with washers.**4. HDPE Handhole and Cover:**

- a. **Size:** Provide handhole and cover with a minimum inside diameter of 24 inches and a minimum of 24 inches in depth. Handhole to be conical in shape with the taper from bottom to top.
- b. **Loading:** Ensure handhole, any extensions, and cover comply as a complete unit with ANSI 77 with a minimum Tier 15 rating.
- c. **Resin:** HDPE resin to comply with ASTM D 790 for minimum flexural modulus of 142,000 psi and ASTM D 638 for minimum yield strength of 3,100 psi when using a Type IV specimen, 2 inch per minute test speed, and 0.075 inch thick molded sample.
- d. **Cover:** Ensure cover has a skid resistant surface meeting PROWAG requirements with stainless steel bolts meeting manufacturer's requirements. Ensure cover fits handhole to meet PROWAG vertical surface discontinuity requirements when placed in pedestrian walkways.

**B. Conduit:****1. General:**

- a. Furnish weatherproof fittings of identical or compatible material to the conduit. Use standard factory elbows, couplings, and other fittings.
- b. Use a manufactured conduit sealing compound that is readily workable material at temperatures as low as 30°F and will not melt or run at temperatures as high as 300°F.

**2.01 UNDERGROUND (Continued)**

- c. Furnish flat polyester pull tape with a minimum pulling strength of 1,250 pounds and permanent sequential footage markings.
- 2. Steel Conduit and Fittings:**
    - a. Comply with ANSI C80.1.
    - b. Use weatherproof expansion fittings with galvanized, malleable iron, fixed and expansion heads jointed by rigid steel conduit sleeves. As an option, the fixed head may be integral with the sleeve, forming a one piece body of galvanized malleable iron.
    - c. Provide steel bushings.
  - 3. Plastic Conduit and Fittings:**
    - a. PVC:**
      - 1) PVC Schedule 40 plastic conduit and fittings complying with NEMA TC-2 (pipe), NEMA TC-3 (fittings), and UL 651 for Schedule 80.
      - 2) Solvent welded, socket type fittings, except where otherwise specified in the contract documents.
      - 3) Threaded adaptors for jointing plastic conduit to rigid metal ducts.
      - 4) Provide bell end fittings or bushings.
    - b. HDPE:**
      - 1) Comply with ASTM F 2160 (conduit) and ASTM D 3350 (HDPE material), SDR 13.5.
      - 2) Use the color specified in the latest NEC or approved by the owner.
      - 3) Continuous reel or straight pieces to minimize splicing.
      - 4) For dissimilar conduit connections, provide an adhesive compatible with both materials.
- C. Wiring and Cable:** Provide wire that is plainly marked on the outside of the sheath with the manufacturer's name and identification of the type of the cable.
- 1. Power Cable:** Comply with [Iowa DOT Article 4185.11](#).
  - 2. Signal Cable:** Comply with IMSA Specifications 19-1 (PVC jacket) or 20-1 (polyethylene jacket) for polyethylene insulated, 600 volt, solid, multi-conductor copper wire, #14 American Wire Gauge (AWG).
  - 3. Tracer Wire:** Comply with #10 AWG, single conductor, stranded copper, type thermoplastic heat and water resistant, nylon-coated (THWN), with UL approval, and an orange colored jacket.
  - 4. Ethernet Cable:** Provide outdoor use rated cable. Provide either Category 5E (CAT5e) or Category 6 (CAT6) cable.
  - 5. Fiber Optic Cable and Accessories:**
    - a. Furnish fiber optic cable of the mode type, size, and number of fibers specified in the contract documents, and all associated accessories.
    - b. Meet the latest applicable standard specifications by ANSI, Electronics Industries Association (EIA), International Telecommunication Unit (ITU), and Telecommunications Industries Association (TIA).
    - c. Multimode Fiber:
      - Core Diameter:  $62.5 \mu\text{m} \pm 1.0 \mu\text{m}$
      - Cladding Diameter:  $125.0 \mu\text{m} \pm 2.0 \mu\text{m}$
      - Core Concentricity:  $\pm 1\%$
      - Max. Attenuation: 3.50 dB/km @ 850  $\mu\text{m}$

**1.08 MEASUREMENT AND PAYMENT (Continued)****P. Dust Control:****1. Water for Dust Control:**

- a. Measurement:** Measurement will be by metering of water applied to haul roads and other areas to control dust. If metering is not available, measurement will be by counting the loads from a transporting tank of known volume and gauging the contents of the transporting truck for partial loads.
- b. Payment:** Payment will be at the unit price per 1,000 gallons of water used.
- c. Includes:** Unit price includes, but is not limited to, furnishing, transporting, and distributing water to the haul road.

**2. Dust Control Product:**

- a. Measurement:** Measurement will be in square yards of the treated area.
- b. Payment:** Payment will be at the unit price per square yard of product applied.
- c. Includes:** Unit price include, but is not limited to, furnishing and incorporating the dust control product.

**Q. Erosion Control Mulching:****1. Conventional Mulching:**

- a. Measurement:** Measurement will be in acres of conventional mulch.
- b. Payment:** Payment will be at the unit price per acre of conventional mulch.
- c. Includes:** Unit price includes, but is not limited to, furnishing and incorporating mulch in the area designated in the contract documents.

**2. Hydromulching:**

- a. Measurement:** Measurement will be in acres for each type of hydromulch.
- b. Payment:** Payment will be at the unit price per acre for each type of hydromulch.
- c. Includes:** Unit price includes, but is not limited to, furnishing mulch and tackifier (if applicable), providing equipment specific to hydromulching, and applying the mulch to the specified area.

**R. Turf Reinforcement Mats (TRM):**

- 1. Measurement:** Measurement will be in squares for each type of turf reinforcement mat, each square containing 100 square feet.
- 2. Payment:** Payment will be at the unit price per square for each type of turf reinforcement mat.
- 3. Includes:** Unit price includes, but is not limited to, excavation, staples, anchoring devices, and material for anchoring slots.

**S. Surface Roughening:**

- 1. Measurement:** Measurement will be in square feet of surface roughening, including directional tracking or grooving/furrowing.
- 2. Payment:** Payment will be at the unit price per square foot of surface roughening.
- 3. Includes:** Unit price includes, but is not limited to, providing equipment to complete directional tracking or grooving/furrowing and completing surface roughening of slopes specified in the contract documents.

**1.08 MEASUREMENT AND PAYMENT (Continued)****T. Inlet Protection Device:****1. Installation:**

- a. Measurement:** Each type of inlet protection device will be counted.
- b. Payment:** Payment will be at the unit price for each inlet protection device.
- c. Includes:** Unit price includes, but is not limited to, removal of the device upon completion of the project.

**2. Maintenance:**

- a. Measurement:** Each inlet protection device maintenance occurrence will be counted.
- b. Payment:** Payment will be at the unit price for each inlet protection device maintenance occurrence.
- c. Includes:** Unit price includes, but is not limited to, removal and off-site disposal of accumulated sediment.

**U. Flow Transition Mat:**

- 1. Measurement:** Measurement will be in square feet of flow transition mat.
- 2. Payment:** Payment will be at the unit price per square foot of flow transition mat.
- 3. Includes:** Unit price includes, but is not limited to, anchoring devices.

**V. End of Season Temporary Erosion Control:**

- 1. Measurement:** Measurement will be in acres of end of season temporary erosion control applied.
- 2. Payment:** Payment will be at the unit price per acre for end of season temporary erosion control.
- 3. Includes:** Unit price includes, but is not limited to, furnishing, placing, and maintaining the end of season temporary erosion control throughout the winter season.

---

**CHAIN LINK FENCE****PART 1 - GENERAL****1.01 SECTION INCLUDES**

- A. Chain Link Fence
- B. Removal and Reinstallation of Existing Fence
- C. Temporary Fence

**1.02 DESCRIPTION OF WORK**

- A. Installation of chain link fence.
- B. Removal and reinstallation of existing fences.
- C. Installation and removal of temporary fence.

**1.03 SUBMITTALS**

Comply with Division 1 - General Provisions and Covenants, as well as the following:

- A. Materials and color samples for vinyl-coated fence fabric.
- B. Upon request, submit certification that products supplied comply with identified specifications.

**1.04 SUBSTITUTIONS**

Comply with Division 1 - General Provisions and Covenants.

**1.05 DELIVERY, STORAGE, AND HANDLING**

Comply with Division 1 - General Provisions and Covenants.

**1.06 SCHEDULING AND CONFLICTS**

Comply with Division 1 - General Provisions and Covenants.

**1.07 SPECIAL REQUIREMENTS**

Provide chain link fencing and gates as completed units, constructed by a single source, including necessary erection accessories, fittings, and fastenings.

**1.08 MEASUREMENT AND PAYMENT****A. Chain Link Fence:****1. Residential:**

- a. **Measurement:** Measurement will be in linear feet for each type and height of fence, measured along the bottom of the fence fabric, excluding the length of gates.
- b. **Payment:** Payment will be at the unit price per linear foot for each type and height of fence installed.
- c. **Includes:** Unit price includes, but is not limited to, posts, fabric, rails, fittings, ties, PVC coating (if specified in the contract documents), excavation of post holes, and concrete encasement of posts.

**1.08 MEASUREMENT AND PAYMENT (Continued)****2. Commercial:**

- a. **Measurement:** Measurement will be in linear feet for each type and height of fence, measured along the bottom of the fence fabric, excluding the length of gates.
- b. **Payment:** Payment will be at the unit price per linear foot for each type and height of fence installed.
- c. **Includes:** Unit price includes, but is not limited to, posts, fabric, rails, braces, truss rods, ties, tension wire, tension bands, tension bars, grounds, fittings, PVC coating (if specified in the contract documents), excavation of post holes, and concrete encasement of posts.

**B. Gates:**

1. **Measurement:** Each type, height, and span of gate will be counted.
2. **Payment:** Payment will be at the unit price for each type, height, and span of gate.
3. **Includes:** Unit price includes, but is not limited to, gate rails, fabric, stretcher bars, braces, vertical stay, hinges, latches, keepers, drop bar lock, center gate stop, and barbed wire (if specified in the contract documents).

**C. Barbed Wire:**

1. **Measurement:** Measurement will be in linear feet for the length of fence to which barbed wire is applied, measured along the top of fence.
2. **Payment:** Payment will be at the unit price per linear foot of barbed wire.
3. **Includes:** Unit price includes, but is not limited to, furnishing and installing all necessary strands of barbed wire, anchors, and barbed wire supporting arms.

**D. Removal and Reinstallation of Existing Fence:**

1. **Measurement:** Measurement will be in linear feet for each type and size of fence removed and reinstalled, measured along the bottom of the fence fabric, including length of gates.
2. **Payment:** Payment will be at the unit price per linear foot for each size and type of fence removed and reinstalled.
3. **Includes:** Unit price includes, but is not limited to, removing vegetation; removing all fence fabric, appurtenances, posts, and gates; removal of concrete encasement from posts; storage of the removed fencing materials to prevent damage; reinstallation of the posts, gates, and fabric, including all appurtenances; and replacement of any fence parts that are not able to be salvaged and reinstalled. Replace items damaged from Contractor's operations with new materials, at no additional cost to the Contracting Authority.

**E. Removal of Fence:**

1. **Measurement:** Measurement will be in linear feet of fence removed, measured along the bottom of fence fabric, including length of gates.
2. **Payment:** Payment will be at the unit price per linear foot of fence removed.
3. **Includes:** Unit price includes, but is not limited to, off-site disposal of fence (including posts, concrete encasement of posts, gates, grounds, and barbed wire) and placing and compacting backfill material in post holes.



**1.08 MEASUREMENT AND PAYMENT (Continued)****F. Temporary Fence:**

1. **Measurement:** Measurement will be in linear feet for each type and height of temporary fence, measured along the bottom of the fence fabric, excluding the length of gates.
2. **Payment:** Payment will be at the unit price per linear foot for each type and height of temporary fence.
3. **Includes:** Unit price includes, but is not limited to, furnishing, installing, and removing posts, fabric, ties, and fittings.

**PART 2 - PRODUCTS****2.01 FABRIC**

- A. General:** Provide fence fabric manufactured from wire meeting the requirements of ASTM A 817. Use No. 9 gauge wire woven in a 2 inch mesh. Construct knuckled selvedge at the top and bottom of the fabric.
- B. Zinc-coated Fabric:** Comply with ASTM A 392.
1. **Wire Coated Prior to Weaving:** Use Type II, Class 5 zinc coating per ASTM A 817.
  2. **Fabric Coated After Weaving:** Use Class 2 coating per ASTM A 392.
- C Aluminum-coated Fabric:** Meet the requirements of ASTM A 491. Coat wire prior to weaving fabric per ASTM A 817, Type I coating.
- D. PVC-coated Fabric:** Comply with ASTM F 668, Class 2b.
1. Apply PVC coating to zinc or aluminum-coated wire prior to weaving fabric.
  2. PVC coating color as specified in the contract documents, complying with ASTM F 934.

**2.02 POSTS, RAILS, AND BRACES**

- A.** Standard weight (Schedule 40) pipe complying with ASTM F 1083.
1. Galvanize pipe inside and out.
  2. Unless otherwise specified in the contract documents, provide the following nominal sizes for the respective uses:

Post Use	Fence Height		
	48" and under (nominal diameter)	48" to 96" (nominal diameter)	Greater than 96" (nominal diameter)
Line Post	2"	2 1/2"	3"
Terminal Post*	2 1/2"	3"	4"
Top/intermediate Rail Braces	1 1/4"	1 1/4"	1 1/4"
Gate Post	Refer to contract documents and ASTM F 900		

\*Includes corner, angle, end, and pull posts.

- B.** Pipe meeting the requirements of ASTM F 1043, Group 1A (Type A coating) or Group 1C (Type B coating). Use nominal sizes specified in ASTM F 1043.
- C.** When PVC-coated fence is specified in the contract documents, coat all posts, rails, and braces with a PVC-coated finish according to ASTM F 1043.
1. Zinc-coated post per ASTM F 1083 prior to application of PVC coating.
  2. Color as specified in the contract documents, complying with ASTM F 934.
- D.** Ensure all posts, rails, and braces provided for a given section of fence have similar coatings and shapes.
- E.** Provide caps for all posts. Comply with ASTM F 626.

**2.03 FITTINGS**

- A. Comply with ASTM F 626.
- B. Provide attachments to connect braces to posts by fittings that will hold both post and brace rigidly.
- C. Provide 3/8 inch diameter round steel diagonal tension rods with an appropriate commercial means for tightening. Provide a locknut or other device to hold the tightening device in place.
- D. Provide a suitable sleeve or coupling device, recommended by the manufacturer, to connect sections of top rail and provide for expansion and contraction.
- E. Use stretcher (tension) bars of the size specified in ASTM F 626 with suitable bands for attaching fabric to corner, end, or gate posts.

**2.04 TIE WIRE AND TENSION WIRE**

- A. **Tie Wire:** Provide tie wires for chain link fence that are the size and type the manufacturer recommends, but no smaller than No. 9 diameter for post ties or No. 12 diameter for rail and brace ties. Comply with ASTM F 626.
- B. **Tension Wire:** Comply with ASTM A 824, with Type I or Type II (Class 3) coating per ASTM A 817.

**2.05 BARBED WIRE SUPPORTING ARMS**

- A. Comply with ASTM F 626 for type of arm configuration specified in the contract documents, as listed below:
  - 1. Type I: Single slanted arm for three barbed wire strands.
  - 2. Type II: Single vertical arm for three barbed wire strands.
  - 3. Type III: V-shaped arm for six barbed wire strands.
  - 4. Type IV: A-shaped arm for five barbed wire strands.
- B. Anchor arms to line, end, corner, and pull posts

**2.06 BARBED WIRE**

Comply with ASTM A 121, design number 12-4-5-14R, Type A or Type Z (Class 3) coating.

**2.07 GATES**

- A. Provide the type, height, and width of gates as specified in the contract documents.
- B. Comply with ASTM F 900.
- C. Provide coating on gate, gate posts, and fabric as required for adjacent fence.

**2.08 CONCRETE**

Provide concrete materials complying with [Section 6010](#).

**2.09 ELECTRICAL GROUND**

- A. **Ground Rod:** 5/8 inch diameter, 8 foot long copper-clad rod.
- B. **Ground Wire:** No. 6 AWG bare copper wire.

---

**PART 3 - EXECUTION****3.01 CHAIN LINK FENCE INSTALLATION**

**A. General:** Comply with ASTM F 567. Construct fence at the location and height specified in the contract documents.

**B. Posts:****1. Post Location:**

- a. Place posts in the line of the fence with equal spacing not to exceed 10 feet on center.
- b. Set terminal (end, corner, and gate) posts at the beginning and end of each continuous length of fence and at abrupt changes in vertical and horizontal alignments. Place pull posts so that no more than 300 linear feet of fence is constructed with only line posts.

**2. Post Setting:**

- a. Dig or drill post holes to the dimensions specified in the contract documents.
- b. Set posts in concrete. Ensure all posts are set plumb in a vertical position.
- c. Form top of concrete footing so it extends 1 inch above grade and is sloped to direct water away from the post. To prevent frost heave, ensure footing is a uniform size to full depth without flare at the top of grade.
- d. Install posts no less than 24 hours prior to installation of fabric.
- e. Set terminal, corner, angle, pull, and gate posts with the required brace-post assembly as specified in the contract documents.

**C. Rails:**

- 1. Top Rail:** Pass the top rail through the base of the line post caps to form a continuous brace from end to end of each stretch of fence. Join rail sections with sleeve or coupling device to allow for expansion and contraction. Securely fasten the top rail to the terminal posts with pressed steel connectors.
- 2. Intermediate Rail:** Securely fasten the intermediate rail between all line posts and terminal posts with pressed steel fasteners. Intermediate rail is required only on fences 8 feet tall and taller.

**D. Braces:**

1. Securely fasten braces to the post by means of malleable iron or pressed steel connections; then truss from the line post back to the end, gate, or corner post.
2. Tighten the diagonal tension rod (truss rod) to produce proper tension.

**E. Fabric:**

1. Install fabric on the outside of the posts from the area being fenced or on the roadway side of the posts.
2. Secure one end of the fabric by a stretcher bar inserted in the final link of the fabric. Pull fabric taut with bottom selvedge, 2 inches above grade, before making attachment elsewhere.
3. Tighten and secure each end of each run of chain link fabric by a stretcher bar inserted in the final link of the fabric. Secure stretcher bar to the end post by tension bands equally spaced no more than 15 inches apart.
4. Attach fence fabric securely to the braces, top rail, tension wire, and all intermediate posts with wire ties or bands at intervals of no more than 12 inches.

**3.01 CHAIN LINK FENCE INSTALLATION (Continued)****F. Bottom Tension Wire:**

1. Install bottom tension wire on fence 5 feet high and taller.
2. Stretch bottom tension wire taut from terminal post to terminal post and securely fasten to each intermediate post within the bottom 6 inches of fabric.

**G. Barbed Wire (When Specified):**

1. Install 3 parallel wires on each barbed wire supporting arm on the outside of the area being secured, unless otherwise specified in the contract documents.
2. Pull wires taut, without kinks or twists, for tension.

**H. Gates:** Install gates as specified in the contract documents.**I. Electrical Grounds:**

1. Install electrical grounds as specified in the contract documents at the following locations:
  - a) Where a primary electrical transmission line (not a secondary feeder line for individual service) passes over the fence. Also install the ground on the fence at a distance of 25 to 50 feet in each direction from the crossing.
  - b) Where the fence is adjacent to and within 50 feet of a primary electrical transmission line, install the ground at 500 foot maximum intervals.
  - c) In at least one location on each applicable straight section of fence.
2. Drive ground rod vertically until the top is 6 inches below the ground surface.
3. Clamp ground wire to the rod and to the fence in such a manner that each element of the fence is grounded.

**3.02 REMOVAL OF EXISTING FENCE**

Remove all fences, including posts and footings, within work areas unless otherwise specified in the contract documents. Remove fence to first line post beyond construction limits. Replace items damaged from Contractor's operations with new materials, at no additional cost to the Contracting Authority.

**3.03 TEMPORARY FENCE**

- A. Furnish and install chain link fence fabric, posts, ties, and other materials for the height specified in the contract documents.
- B. Install according to permanent fence installation specifications, with the following exceptions:
  1. Drive posts into the ground. Do not set posts in concrete except at corner or temporary gate posts.
  2. Top rail, tension wire, and bracing will not be required.
- C. Remove temporary fence and materials when no longer necessary. Place suitable backfill material in post holes. Fence materials will remain the property of the Contractor and removed from the site.

END OF SECTION



*This page was intentionally left blank*

Place fence fabric on roadway side of post. For certain curves, stream crossings, or other locations, the Contractor has the option to place fabric on the side of the post away from the roadway.

Residential chain link fence does not include braces, truss rod assembly, tension wire, tension bar, tension band, or grounds

- ① Fabric width as specified in the contract documents.
- ② For fence heights greater than 8 feet, the depth of the fence post footing is 3 feet plus 3 inches for each 1 foot in height over 8 feet.
- ③ Install the fence on the roadway side of the right-of-way when specified in the contract documents.

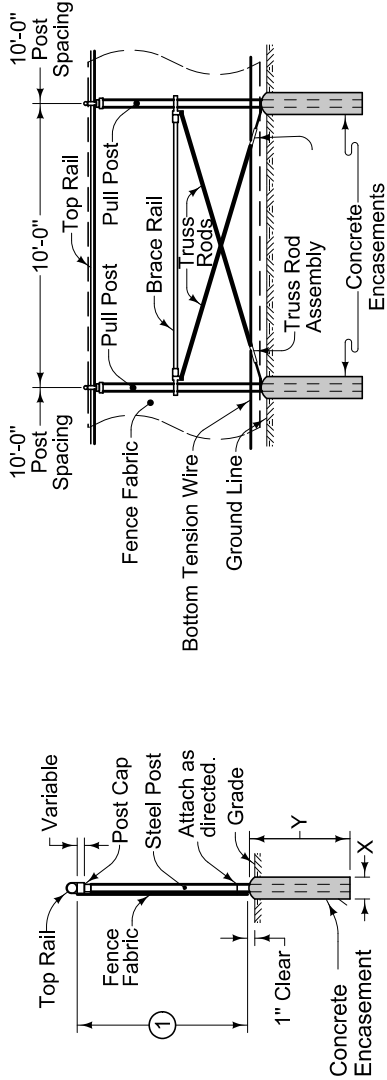

**POST INSTALLATION**

**PULL POST INSTALLATION**

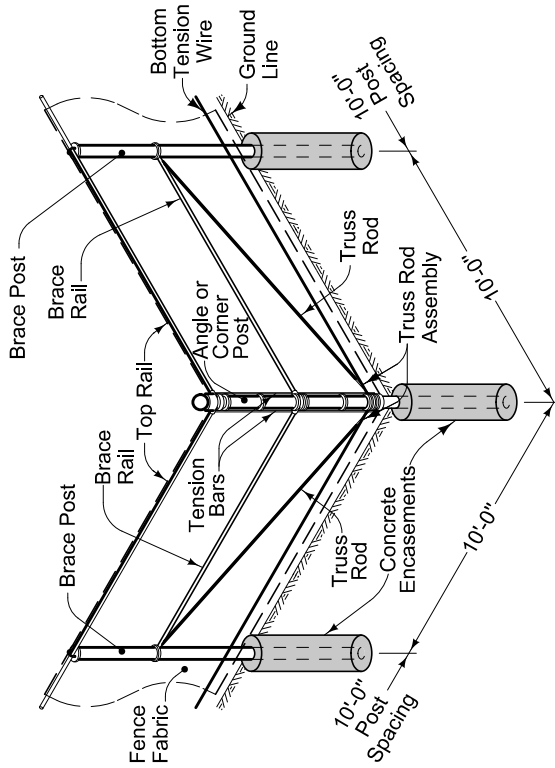

**ANGLE OR CORNER POST INSTALLATION**

**FENCE POST FOOTING DEPTH AND DIAMETER**

USE IN FENCE	FENCE HEIGHT			
	4'-0" and less	Over 4'-0" to 8'-0"	Over 8'-0"	
Line and Brace Posts	X	Y	X	Y
Terminal Post*	0'-8"	3'-0"	0'-10"	3'-0"
	0'-10"	3'-0"	1'-0"	3'-0"

\*Includes corner, angle, end, and pull posts.

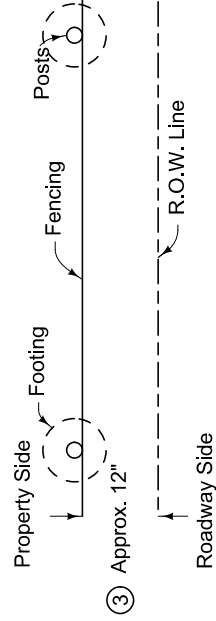

**PLAN OF FENCE**

**SUDAS**

REVISION  
1 2024  
**9060.101**  
SHEET 1 of 2

SUDAS Standard Specifications

CHAIN LINK FENCE



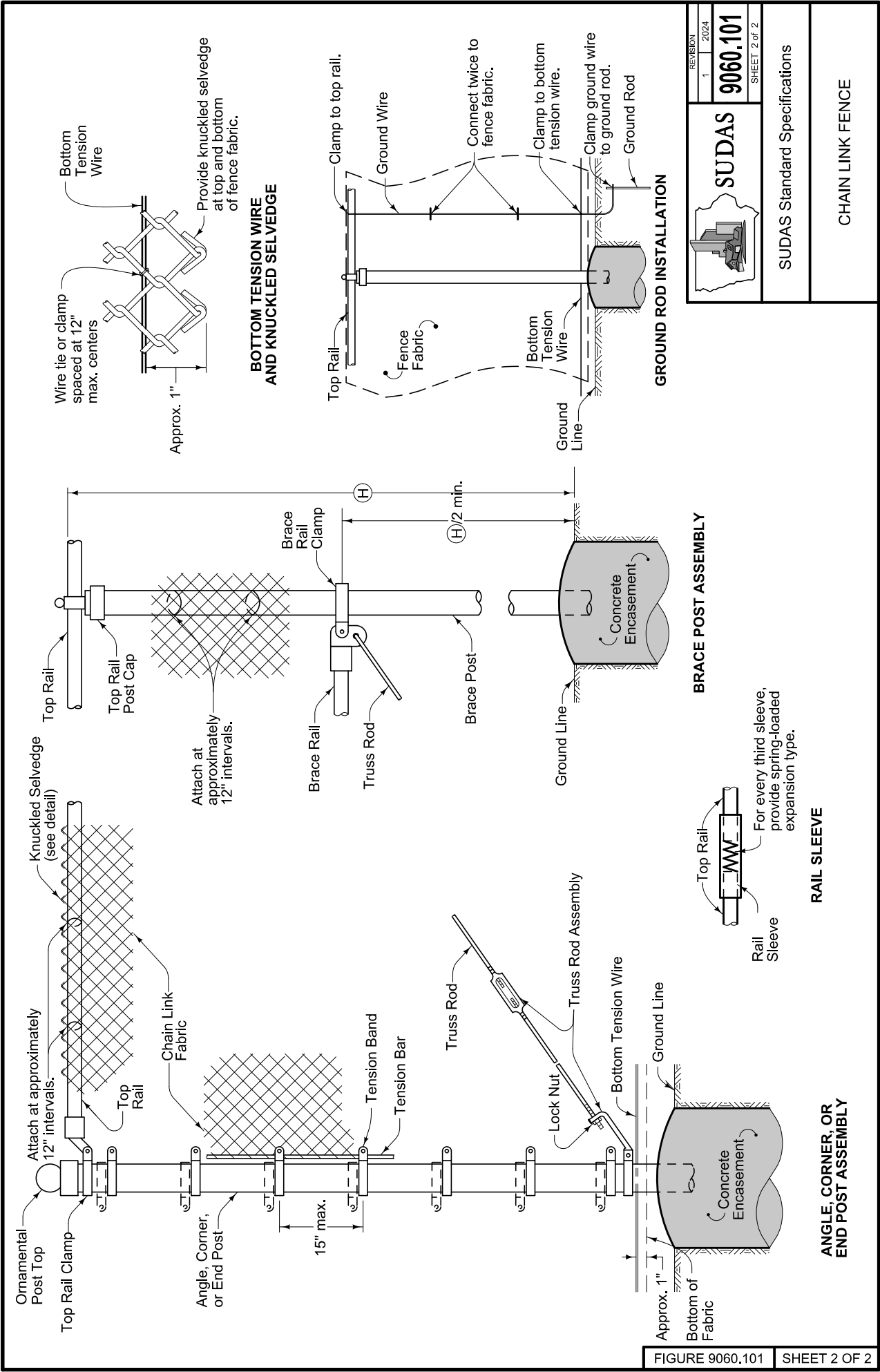

	REVISION 1 2024
	<b>9060.101</b> SHEET 2 of 2

SUDAS Standard Specifications

CHAIN LINK FENCE



**CONCRETE STEPS, HANDRAILS, AND SAFETY RAIL****PART 1 - GENERAL****1.01 SECTION INCLUDES**

- A. Concrete Steps
- B. Handrails
- C. Safety Rail

**1.02 DESCRIPTION OF WORK**

- A. Construction of concrete steps.
- B. Furnishing and installation of handrails.
- C. Furnishing and installation of safety rail.

**1.03 SUBMITTALS**

Comply with Division 1 - General Provisions and Covenants, as well as the following:

- A. Submit color samples and product literature for primer, paint, and powder coating to be used on handrails and safety rail.
- B. Submit shop drawings for handrails and safety rail.

**1.04 SUBSTITUTIONS**

Comply with Division 1 - General Provisions and Covenants.

**1.05 DELIVERY, STORAGE, AND HANDLING**

Comply with Division 1 - General Provisions and Covenants.

**1.06 SCHEDULING AND CONFLICTS**

Comply with Division 1 - General Provisions and Covenants.

**1.07 SPECIAL REQUIREMENTS**

- A. Provide 1 gallon of color matched exterior grade polyurethane paint for each color specified, for the Contracting Authority's maintenance use.
- B. Label each container with the manufacturer's name, product number, and color number.

**1.08 MEASUREMENT AND PAYMENT****A. Concrete Steps:**

1. **Measurement:** Measurement will be the area of concrete steps in square feet for each type of concrete step. The length will be the horizontal length between expansion joints, and the width will include curbs.
2. **Payment:** Payment will be at the unit price per square foot of concrete steps.
3. **Includes:** Unit price includes, but is not limited to, reinforcement, expansion joint material, and preparation of subgrade.

**B. Handrail:**

1. **Measurement:** Measurement will be in linear feet for each type of handrail, measured along the top of the handrail from end of rail to end of rail.
2. **Payment:** Payment will be at the unit price per linear foot for each type of handrail.
3. **Includes:** Unit price includes, but is not limited to, posts, mounting hardware or concrete grout, and finishing (painted, galvanized, or powder coated).

**C. Safety Rail:**

1. **Measurement:** Measurement will be in linear feet for safety rail, measured along the top of the safety rail from end post to end post.
2. **Payment:** Payment will be at the unit price per linear foot of safety rail.
3. **Includes:** Unit price includes, but is not limited to, posts, concrete for ground mounting, pickets, mounting hardware, epoxy grout, and finishing (painted, galvanized, or powder coated).