

Table of Contents

Section 6010 - Structures for Sanitary and Storm Sewers		Page No.
Part 1 - General		
1.01	Section Includes	1
1.02	Description of Work	1
1.03	Submittals	1
1.04	Substitutions	1
1.05	Delivery, Storage, and Handling	2
1.06	Scheduling and Conflicts	2
1.07	Special Requirements	2
1.08	Measurement and Payment	2
Part 2 - Products		
2.01	Manhole and Intake Types	5
2.02	Precast	5
2.03	Cast-in-Place	5
2.04	Non-shrink Grout	6
2.05	Precast Riser Joints	6
2.06	Manhole or Intake Top	6
2.07	Base	6
2.08	Pipe Connections	7
2.09	Manhole or Intake Adjustment Rings (Grade Rings)	7
2.10	Castings (Ring, Cover, Grate, and Extensions)	7
2.11	Additional Materials for Sanitary Sewer Manholes	9
2.12	Concrete Fillet	10
2.13	Steps	10
2.14	Precast Concrete Tee	10
2.15	Casting Anchor Bolts and Washers	11
2.16	Drop Connection	11
2.17	Excavation and Backfill Material	11

Section 6010 - Structures for Sanitary and Storm Sewers (Continued)**Page No.****Part 3 - Execution**

3.01	General Requirements for Installation of Manholes and Intakes	12
3.02	Additional Requirements for Cast-in-place Concrete Structures	14
3.03	Additional Requirements for Precast Concrete Structures	16
3.04	Adjustment of Existing Manhole or Intake	16
3.05	Connection to Existing Manhole or Intake	17
3.06	Drop Connection to Sanitary Sewer Manhole	18
3.07	Removal of Manhole or Intake	19
3.08	Cleaning, Inspection, and Testing	19

Figures**Figure No.**

Circular Sanitary Sewer Manhole	6010.301
Rectangular Sanitary Sewer Manhole	6010.302
Sanitary Sewer Manhole Over Existing Sewer	6010.303
Rectangular Base/Circular Top Sanitary Sewer Manhole	6010.304
Tee-section Sanitary Sewer Manhole	6010.305
<i>RESERVED FOR FUTURE USE</i>	6010.306
External Drop Connection for Sanitary Sewer Manhole	6010.307
Internal Drop Connection for Sanitary Sewer Manhole	6010.308
Circular Storm Sewer Manhole	6010.401
Rectangular Storm Sewer Manhole	6010.402
Deep Well Rectangular Storm Sewer Manhole	6010.403
Rectangular Base/Circular Top Storm Sewer Manhole	6010.404
Tee-section Storm Sewer Manhole	6010.405
Shallow Rectangular Storm Sewer Manhole	6010.406
Single Grate Intake	6010.501
Circular Single Grate Intake	6010.502
Single Grate Intake with Manhole	6010.503
Single Grate Intake with Flush-top Manhole	6010.504
Double Grate Intake	6010.505

Section 6010 - Structures for Sanitary and Storm Sewers (Continued)	Figure No.
Double Grate Intake with Manhole	6010.506
Single Open-throat Curb Intake, Small Box	6010.507
Single Open-throat Curb Intake, Large Box	6010.508
Double Open-throat Curb Intake, Small Box	6010.509
Double Open-throat Curb Intake, Large Box	6010.510
Rectangular Area Intake	6010.511
Circular Area Intake	6010.512
Open-sided Area Intake	6010.513
Boxouts for Grate Intakes	6010.514
Triple Rectangular Area Intake	6010.515
Large Well Double Grate Intake with Manhole	6010.516
Linear Trench Drain	6010.521
Open-throat Curb Intake Under Pavement	6010.541
Extension Unit for Open-throat Curb Intake Under Pavement	6010.542
Single Open-throat Curb Intake with Extended Opening	6010.545
Castings for Sanitary Sewer Manholes	6010.601
Castings for Storm Sewer Manholes	6010.602
Castings for Grate Intakes	6010.603
Castings for Area Intakes	6010.604

Section 6020 - Rehabilitation of Existing Manholes	Page No.
---	-----------------

Part 1 - General	
-------------------------	--

1.01	Section Includes	1
1.02	Description of Work	1
1.03	Submittals	1
1.04	Substitutions	1
1.05	Delivery, Storage, and Handling	1
1.06	Scheduling and Conflicts	1
1.07	Special Requirements	1
1.08	Measurement and Payment	1

Section 6020 - Rehabilitation of Existing Manholes (Continued)		Page No.
Part 2 - Products		
2.01	Infiltration Barrier	3
2.02	In-situ Manhole Replacement, Cast-in-place Concrete	3
2.03	Centrifugally Cast Cementitious Mortar Liner with Epoxy Seal	3
Part 3 - Execution		
3.01	Infiltration Barrier	5
3.02	In-situ Manhole Replacement, Cast-in-place Concrete	5
3.03	Centrifugally Cast Cementitious Mortar Liner with Epoxy Seal	6
3.04	Cleaning, Inspection, and Testing	6
Section 6030 - Cleaning, Inspection, and Testing of Structures		Page No.
Part 1 - General		
1.01	Section Includes	1
1.02	Description of Work	1
1.03	Submittals	1
1.04	Substitutions	1
1.05	Delivery, Storage, and Handling	1
1.06	Scheduling and Conflicts	1
1.07	Special Requirements	1
1.08	Measurement and Payment	1
Part 2 - Products		
	None.	
Part 3 - Execution		
3.01	Cleaning	2
3.02	Visual Inspection	2
3.03	Repair	2
3.04	Sanitary Sewer Manhole Testing	2
3.05	Test Failure	4

STRUCTURES FOR SANITARY AND STORM SEWERS**PART 1 - GENERAL****1.01 SECTION INCLUDES**

- A. Manholes and Intakes for Storm Sewers
- B. Manholes for Sanitary Sewers
- C. Adjustment of Existing Manholes and Intakes
- D. Connection to Existing Manholes and Intakes
- E. Removal of Manholes and Intakes
- F. Special Structures for Storm Sewers
- G. Excavation and Backfill of Structures

1.02 DESCRIPTION OF WORK

- A. Construct sanitary and storm sewer manholes to provide access to sewer systems for maintenance and cleaning purposes.
- B. Construct storm sewer intakes for collection of surface water and conveyance to the storm sewer system.
- C. Modify existing manholes and intakes as necessitated by other improvements adjacent to the manholes or intakes.

1.03 SUBMITTALS

Comply with Division 1 - General Provisions and Covenants, as well as the following:

- A. Shop drawings of steel reinforcement, showing sizes, lengths, bends, and counts, if required.
- B. Concrete mix design, if required by Engineer.
- C. Shop drawing schedule of new manholes and/or intakes showing total depth, relative elevations of all connecting sanitary or storm sewer lines, all drops, and orientation of connecting lines.
- D. Results of required testing.
- E. Catalog cuts of iron castings and sewer line connection gaskets.
- F. Gradation and soil classification reports for structure bedding and backfill materials.
- G. Dewatering plan.

1.04 SUBSTITUTIONS

Comply with Division 1 - General Provisions and Covenants.

1.05 DELIVERY, STORAGE, AND HANDLING

Comply with Division 1 - General Provisions and Covenants, as well as the following:

- A. Store reinforcing steel only on pallets or lagging.
- B. Follow the aggregate storage and concrete transport requirements in [Iowa DOT Article 2301.02, C.](#)

1.06 SCHEDULING AND CONFLICTS

Comply with Division 1 - General Provisions and Covenants.

1.07 SPECIAL REQUIREMENTS

- A. Do not place concrete when stormy or inclement weather will prevent good quality work.
- B. Cold weather placement is restricted per [Iowa DOT Article 2403.03, F.](#)

1.08 MEASUREMENT AND PAYMENT**A. Manhole:**

- 1. **Measurement:** Each type and size of manhole will be counted.
- 2. **Payment:** Payment will be at the unit price for each type and size of manhole.
- 3. **Includes:** Unit price includes, but is not limited to, excavation; furnishing and installing pipe; lining (if specified); furnishing, placing, and compacting bedding and backfill material; base; structural concrete; reinforcing steel; precast units (if used); concrete fillets; pipe connections; infiltration barriers (sanitary sewer manholes only); castings; and adjustment rings.

B. Intake:

- 1. **Measurement:** Each type and size of intake will be counted.
- 2. **Payment:** Payment will be at the unit price for each type and size of intake.
- 3. **Includes:** Unit price includes, but is not limited to, excavation; furnishing and installing pipe; furnishing, placing, and compacting bedding and backfill material; base; structural concrete; reinforcing steel; precast units (if used); concrete fillets; pipe connections; castings; and adjustment rings.

C. Drop Connection:**1. Internal Drop Connection:**

- a. **Measurement:** Each size of internal drop connection will be counted.
- b. **Payment:** Payment will be at the unit price for each size of internal drop connection.
- c. **Includes:** Unit price includes, but is not limited to, cutting the hole and installing a flexible watertight connector, providing and installing the receiving bowl, flexible coupler between the bowl and the drop pipe, the PVC drop pipe, pipe brackets and bolts, the bottom elbow, repair of fillet if required, and a splash guard if required.

2. External Drop Connection:

- a. **Measurement:** Each size of external drop connection will be counted.
- b. **Payment:** Payment will be at the unit price for each size of external drop connection.
- c. **Includes:** Unit price includes, but is not limited to, the connection to the manhole and all pipe; fittings; concrete encasement; and furnishing, placing, and compacting bedding and backfill material.

1.08 MEASUREMENT AND PAYMENT (Continued)**D. Casting Extension Rings:**

1. **Measurement:** Each casting extension ring will be counted.
2. **Payment:** Payment will be at the unit price for each casting extension ring.
3. **Includes:** Unit price includes, but is not limited to, furnishing and installing each casting extension ring and reinstalling the casting lid.

E. Manhole or Intake Adjustment, Minor:**1. Manhole Adjustment, Minor:**

- a. **Measurement:** Each existing manhole adjusted to finished grade by addition or removal of adjustment rings or adjustment of adjustable casting will be counted.
- b. **Payment:** Payment will be made at the unit price for each minor manhole adjustment.
- c. **Includes:** Unit price includes, but is not limited to, removing existing casting and existing adjustment rings, furnishing and installing adjustment rings, furnishing and installing new casting, and installing new infiltration barrier (sanitary sewer manholes only).

2. Intake Adjustment, Minor:

- a. **Measurement:** Each existing intake adjusted to finished grade by addition or removal of adjustment rings or adjustment of adjustable casting will be counted.
- b. **Payment:** Payment will be made at the unit price for each minor intake adjustment.
- c. **Includes:** Unit price includes, but is not limited to, removing existing casting and existing adjustment rings, furnishing and installing adjustment rings, and furnishing and installing new casting.

F. Manhole or Intake Adjustment, Major:**1. Manhole Adjustment, Major:**

- a. **Measurement:** Each existing manhole adjusted to grade by addition or removal of riser, cone or flat top sections, or the exchange of existing riser sections with sections having different vertical dimensions will be counted.
- b. **Payment:** Payment will be at the unit price for each major adjustment.
- c. **Includes:** Unit price includes, but is not limited to, removal of existing casting, adjustment rings, top sections, and risers; excavation; concrete and reinforcing steel or precast sections; furnishing and installing new casting; installing new infiltration barrier (sanitary sewer manholes only); placing backfill material; and compaction.

2. Intake Adjustment, Major:

- a. **Measurement:** Each existing intake adjusted to grade by addition or removal of riser, cone or flat top sections, or the exchange of existing riser sections with sections having different vertical dimensions will be counted.
- b. **Payment:** Payment will be at the unit price for each major adjustment.
- c. **Includes:** Unit price includes, but is not limited to, removal of existing casting, adjustment rings, top sections, and risers; excavation; concrete and reinforcing steel or precast sections; furnishing and installing new casting; placing backfill material; and compaction.

1.08 MEASUREMENT AND PAYMENT (Continued)**G. Connection to Existing Manhole or Intake:****1. Connection to Existing Manhole:**

- a. **Measurement:** Each connection made to an existing manhole will be counted.
- b. **Payment:** Payment will be made at the unit price for each sewer connection.
- c. **Includes:** Unit price includes, but is not limited to, coring or cutting into the existing manhole or intake, removal of existing fillet, pipe connections, replacement of fillet, grout, and waterstop (when required).

2. Connection to Existing Intake:

- a. **Measurement:** Each connection made to an existing intake will be counted.
- b. **Payment:** Payment will be made at the unit price for each sewer connection.
- c. **Includes:** Unit price includes, but is not limited to, coring or cutting into the existing manhole or intake, removal of existing fillet, pipe connections, replacement of fillet, grout, and waterstop (when required).

H. Remove Manhole or Intake:**1. Remove Manhole:**

- a. **Measurement:** Each manhole removed will be counted.
- b. **Payment:** Payment will be made at the unit price for each manhole.
- c. **Includes:** Unit price includes, but is not limited to, removal of casting, concrete, and reinforcement; plugging pipes; filling remaining structure with flowable mortar; and placing compacted fill over structure to finished grade.

2. Remove Intake:

- a. **Measurement:** Each intake removed will be counted.
- b. **Payment:** Payment will be made at the unit price for each intake.
- c. **Includes:** Unit price includes, but is not limited to, removal of casting, concrete, and reinforcement; plugging pipes; filling remaining structure with flowable mortar; and placing compacted fill over structure to finished grade.

PART 2 - PRODUCTS**2.01 MANHOLE AND INTAKE TYPES****Table 6010.01: Manhole and Intake Types**

	Figure No.	Type	Description
Sanitary Sewer Manholes	6010.301	SW-301	Circular Sanitary Sewer Manhole
	6010.302	SW-302	Rectangular Sanitary Sewer Manhole
	6010.303	SW-303	Sanitary Sewer Manhole Over Existing Sewer
	6010.304	SW-304	Rectangular Base/Circular Top Sanitary Sewer Manhole
	6010.305	SW-305	Tee-section Sanitary Sewer Manhole
Storm Sewer Manholes	6010.401	SW-401	Circular Storm Sewer Manhole
	6010.402	SW-402	Rectangular Storm Sewer Manhole
	6010.403	SW-403	Deep Well Rectangular Storm Sewer Manhole
	6010.404	SW-404	Rectangular Base/Circular Top Storm Sewer Manhole
	6010.405	SW-405	Tee-section Storm Sewer Manhole
	6010.406	SW-406	Shallow Rectangular Storm Sewer Manhole
Intakes	6010.501	SW-501	Single Grate Intake
	6010.502	SW-502	Circular Single Grate Intake
	6010.503	SW-503	Single Grate Intake with Manhole
	6010.504	SW-504	Single Grate Intake with Flush-top Manhole
	6010.505	SW-505	Double Grate Intake
	6010.506	SW-506	Double Grate Intake with Manhole
	6010.507	SW-507	Single Open-throat Intake, Small Box
	6010.508	SW-508	Single Open-throat Intake, Large Box
	6010.509	SW-509	Double Open-throat Intake, Small Box
	6010.510	SW-510	Double Open-throat Intake, Large Box
	6010.511	SW-511	Rectangular Area Intake
	6010.512	SW-512	Circular Area Intake
	6010.513	SW-513	Open-sided Area Intake
	6010.515	SW-515	Triple Rectangular Area Intake
	6010.541	SW-541	Open-Throat Curb Intake Under Pavement
6010.542	SW-542	Extension Unit for Open-Throat Curb Intake Under Pavement	
6010.545	SW-545	Single Open-Throat Curb Intake with Extended Opening	

2.02 PRECAST

Comply with ASTM C 478 (circular) and ASTM C 913 (rectangular).

2.03 CAST-IN-PLACE

A. Concrete: Use Class C concrete. Comply with the following Iowa DOT Specifications and Materials I.M.s.

1. Iowa DOT Specifications Sections:

- a. [2403](#) – Structural Concrete
- b. [4101](#) – Portland Cement
- c. [4102](#) – Water for Concrete and Mortar
- d. [4103](#) – Liquid Admixtures for Portland Cement Concrete
- e. [4104](#) – Burlap for Curing Concrete
- f. [4106](#) – Plastic Film and Insulating Covers for Curing Concrete
- g. [4108](#) – Supplementary Cementitious Materials
- h. [4109](#) – Aggregate Gradations
- i. [4110](#) – Fine Aggregate for Portland Cement Concrete
- j. [4115](#) – Coarse Aggregate for Portland Cement Concrete

2.03 CAST-IN-PLACE (Continued)**2. Iowa DOT Materials I.M.s:**

- a. [316](#) – Flexural Strength of Concrete
- b. [318](#) – Air Content of Freshly Mixed Concrete by Pressure
- c. [403](#) – Chemical Admixtures for Concrete
- d. [528](#) – Structural Concrete Plant Inspection
- e. [529](#) – Portland Cement Concrete Proportions
- f. [534](#) – Mobile Mixture Inspection

B. Reinforcement: Comply with [Iowa DOT Section 4151](#) for epoxy coated reinforcement.

2.04 NON-SHRINK GROUT

Comply with [Iowa DOT Materials I.M. 491.13](#).

2.05 PRECAST RISER JOINTS**A. Joint Ends:**

1. Use tongue and groove ends.
2. If cast-in-place base is used, provide bottom riser with square bottom edge.

B. Joint Sealant:**1. Sanitary Sewers:**

- a. **Rubber O-ring or Profile Gasket:** Flexible joint, complying with ASTM C 443.
- b. **Bituminous Jointing Material:** Use a cold-applied mastic sewer joint sealing compound recommended by the manufacturer for the intended use and approved by the Engineer. Comply with ASTM C 990.
- c. **Butyl Sealant Wrap:** Comply with ASTM C 877.

2. Storm Sewers: All joint sealants used on sanitary sewers may also be used for storm sewers. The following may also be used.

- a. **Rubber Rope Gasket Jointing Material:** Comply with ASTM C 990.
- b. **Engineering Fabric Wrap:** If specified in the contract documents, supply engineering fabric wrap complying with [Iowa DOT Article 4196.01, B](#).

2.06 MANHOLE OR INTAKE TOP

- A. Capable of supporting HS-20 loading.
- B. Use eccentric cone on sanitary sewer manholes unless otherwise specified or allowed.

2.07 BASE**A. Sanitary Sewer Manhole:**

1. **Circular Manhole:** Integral base and lower riser section according to ASTM C 478.
2. **All Other Manholes:** Use precast or cast-in-place concrete base.

B. Storm Sewer Manhole: Use precast or cast-in-place concrete base.

C. Intake: Use precast or cast-in-place concrete base.

2.08 PIPE CONNECTIONS

- A. Flexible, Watertight Gasket:** Comply with ASTM C 923.
- B. Non-Shrink Grout:** Comply with Section 6010, 2.04.
- C. Waterstop:** Provide elastomeric gasket that surrounds pipe and attaches with stainless steel bands and is designed to stop the movement of water along the interface between a pipe and a surrounding concrete collar.
- D. Concrete Collar:** Comply with Section 6010, 2.02 and 2.03.

2.09 MANHOLE OR INTAKE ADJUSTMENT RINGS (Grade Rings)

- A. Use one of the following materials for grade adjustments of manhole or intake frame and cover assemblies:
 1. Reinforced Concrete Adjustment Rings: Comply with ASTM C 478. Provide rings free from cracks, voids, and other defects.
 2. High Density Polyethylene Adjustment Rings: Comply with ASTM D 1248 for recycled plastic.
 - a. Test and certify material properties by the methods in the following table.

Table 6010.02: Test Methods

Property	Test Method	Acceptable Value
Melt Flow Index	ASTM D 1238	0.30 to 30 g/10 min.
Density	ASTM D 792	0.94 to 0.98 g/cm ³
Tensile Strength	ASTM D 638	2,000 to 5,000 lb/in ²

- a. Do not use polyethylene grade adjustment rings when they are exposed to heat shrink infiltration barriers.
 - b. When used in a single configuration, provide tapered adjustment ring with thickness that varies from 1/2 inch to 3 inches.
 - c. Install adjustment rings on clean, flat surfaces according to the manufacturer's recommendations. Comply with ASTM D 36 with minimum 350°F softening point for butyl rubber sealant.
3. Expanded Polypropylene Adjustment Rings: Comply with ASTM D 4819 for expanded polypropylene when tested according to ASTM D 3575.
 - a. Use adhesive meeting ASTM C 920, Type S, Grade N5, Class 25.
 - b. Provide finish rings with grooves on the lower surface and flat upper surface.
 - c. Do not use when heat shrinkable infiltration barrier is used.
- B. Ensure the inside diameter of the adjustment ring is not less than the inside diameter of the manhole frame or not less than the inside dimension of the intake grate opening.

2.10 CASTINGS (Ring, Cover, Grate, and Extensions)

- A. Gray Cast Iron:** AASHTO M 306.
- B. Ductile Iron:** ASTM A 536, Grade 80-55-06 or 70-50-05.

2.10 CASTINGS (Ring, Cover, Grate, and Extensions) (Continued)**C. Composite:** AASHTO M 306.

1. **Hardware:** Attach lid to frame with 316 stainless steel hardware.
2. **Slip Resistance:** Greater than 0.6 when tested according to ASTM C 1028.
3. **Ultraviolet Resistance:** Meet ASTM G 154 Cycle 1 for a minimum of 1,000 hours.
4. **Detection:** Must be detectable using standard detection equipment.

D. Load Capacity: Standard duty unless otherwise shown on the casting figures.

1. **Standard Duty:** Casting certified for 40,000 pound proof-load according to AASHTO M 306.
2. **Light Duty:** Casting certified according to requirements of AASHTO M 306 for a 16,000 pound proof-load (HS-20). 40,000 pound proof-load is not required.

E. Casting Types:

1. **Manholes:** The following table lists the manhole casting types.

Table 6010.03: Manhole Casting Types

	Figure No.	Casting Type	Number of Pieces	Ring/Cover	Bolted Frame	Bolted Cover (Floodable)	Gasket
Sanitary Sewer	6010.601	SW-601, A	2	Fixed	Yes	No	Yes ¹
	6010.601	SW-601, B	3	Adjustable	No	No	Yes ¹
	6010.601	SW-601, C	2	Fixed	Yes	Yes	Yes ¹
	6010.601	SW-601, D	3	Adjustable	No	Yes	Yes ¹
Storm Sewer	6010.602	SW-602, E²	2	Fixed	Yes	No	No
	6010.602	SW-602, F²	3	Adjustable	No	No	No
	6010.602	SW-602, G²	2	Fixed	No	No	No

¹ Machine bearing surfaces required.² Storm sewer casting may include environmental symbols and/or messages such as "DUMP NO WASTE, DRAINS TO RIVER."**2. Intakes:**

- a. Comply with [Figures 6010.602](#), [6010.603](#), [6010.604](#), and the contract documents.
- b. Castings may include environmental symbols and/or messages such as "DUMP NO WASTE, DRAINS TO RIVER."

3. Manhole Casting Extension Ring:

- a. Match the dimensions of the existing ring and cover with an allowable diameter tolerance of -1/4 inch for the frame ridge and +1/4 inch for the cover recess.
- b. Provide extension ring with height as required to raise the top of the casting to make it level or no more than 1/4 inch below the finished pavement surface. Maximum ring height is 3 inches.

2.11 ADDITIONAL MATERIALS FOR SANITARY SEWER MANHOLES**A. Infiltration Barrier:****1. External Chimney Seal:****a. Rubber Sleeve and Extension:**

- 1) Corrugated; minimum thickness of 3/16 inches, according to ASTM C 923.
- 2) Minimum allowable vertical expansion of at least 2 inches.

b. Compression Bands:

- 1) One-piece band assembly to compress sleeve or extension against manhole and casting surfaces.
- 2) 16 gauge ASTM C 923, Type 304 stainless steel, minimum 1 inch width, minimum adjustment range of 4 inches more than the manhole outside diameter.
- 3) For standard two-piece castings, shape top band to lock sleeve to manhole frame's base flange. For three-piece adjustable castings, shape top band to lock sleeve to upper piece of adjustable frame.
- 4) Stainless steel fasteners complying with ASTM F 593 and 594, Type 304.

2. Internal Chimney Seal:**a. Rubber Sleeve and Extension:**

- 1) Double pleated, minimum thickness 1/8 inch thick, according to ASTM C 923.
- 2) Minimum allowable vertical expansion of at least 2 inches.
- 3) Integrally formed expansion band recess top and bottom with multiple sealing fins.

b. Expansion Bands:

- 1) One-piece band assembly to compress sleeve or extension against manhole and casting surfaces to make a watertight seal.
- 2) 16 gauge ASTM C 923, Type 304 stainless steel, minimum 1 inch width, minimum adjustment range of 2 inches more than the manhole inside diameter.
- 3) Positive stainless steel locking mechanism permanently securing the band in its expanded position after tightening.

3. Molded Shield:**a. Barrier Shield:**

- 1) Medium density polyethylene, according to ASTM D 1248.
- 2) Certified for 40,000 pound proof-load according to AASHTO M 306.
- 3) Diameter to match cone section and internal dimension of casting.

b. Sealant: Butyl material meeting ASTM C 990.**4. Heat Shrink Sleeve:** Heat-shrinkable wrap around sleeve designed for protection of buried and exposed sanitary sewer manholes. Do not use with polypropylene or polyethylene adjustment rings.**a. Primer:** Compatible with concrete, ductile and cast iron, and sleeve material.**b. Sleeve and Backing:**

Property	Standard	Value
Water Absorption	ASTM D 570	0.05% maximum
Low Temperature Flexibility	ASTM D 2671	-40° F
Tensile Strength	ASTM D 638	2,900 psi minimum
Elongation	ASTM D 638	600% minimum
Hardness	ASTM D 2240	Shore D: 46
Shrink Factor	---	40% minimum
Thickness	---	0.1 inch minimum

c. Adhesive: Softening point of 212° F maximum meeting ASTM E 28.

2.11 ADDITIONAL MATERIALS FOR SANITARY SEWER MANHOLES (Continued)**B. Riser Section Coating:**

1. **Exterior:** When exterior waterproof coating is specified, provide bituminous or coal tar coating.
2. **Interior:** When interior manhole lining is specified, provide lining according to [Section 4010, 2.01](#) (lined, reinforced concrete pipe).

2.12 CONCRETE FILLET

A. Cast-in-place Base: Provide a cast-in-place concrete fillet with concrete complying with the requirements of Section 6010, 2.03.

B. Precast Base Section:

1. For sanitary sewers, provide a precast concrete fillet, unless otherwise allowed by the Engineer. Comply with Section 6010, 3.01.
2. For storm sewers, provide a cast-in-place concrete fillet with concrete complying with the requirements of Section 6010, 2.03.

2.13 STEPS**A. Depths:**

1. For manholes and intakes less than 20 feet deep, do not install steps unless otherwise specified in the contract documents.
2. For manholes and intakes deeper than 20 feet, install steps to meet OSHA regulations.

B. Requirements:

1. ASTM C 478.
2. Manufacture using polypropylene encased steel.
3. Uniformly space steps at 12 to 16 inches.
4. Align with vertical side of eccentric top section.
5. Place first step no more than 36 inches from top of casting.

2.14 PRECAST CONCRETE TEE

A. Tee and Eccentric Reducers: ASTM C 478.

B. Composite Tee: Comply with [Figure 6010.305](#). May be substituted for pipe diameters less than 48 inches.

2.15 CASTING ANCHOR BOLTS AND WASHERS

- A. Material:** Stainless steel or hot-dipped galvanized.
- B. Diameter:** Provide bolts and washers 1/8 inch smaller than hole or slot in the casting frame, but no less than 1/2 inch diameter.
- C. Bolt Length:** As required to pass through adjustment rings and into manhole or intake structure to embedment depth recommended by anchor manufacturer.

2.16 DROP CONNECTION**A. Internal:**

- 1. Receiving Bowl:** Marine grade fiberglass meeting ASTM D 790, ASTM D 638, and ASTM D 2583 with non-magnetic stainless steel anchor bolts meeting the manufacturer's recommendation.
- 2. Flexible Coupler:** Provide flexible couple matching the size of the receiving bowl and the drop pipe.
- 3. Drop Pipe and Bottom Elbow:** Provide drop pipe an equivalent diameter of the influent pipe. Limit pipe size to maintain space available for maintenance activities. Provide solid wall SDR 35 PVC pipe and elbow complying with [Section 4010, 2.01, A](#) or Schedule 40 PVC pipe and elbow complying with ASTM D 1785.
- 4. Pipe Brackets:** ASTM A 240, Type 304 or Type 316 stainless steel with stainless steel nuts and bolts.

B. External:

- 1. Pipe and Fittings:** Comply with [Section 4010, 2.01, G](#) for ductile iron pipe and fittings.
- 2. Concrete Encasement:** Comply with [Section 7010, 2.02](#).
- 3. Embedment Material:** Comply with [Section 3010, 2.02, A](#) or [2.06](#) for backfill material from the top of the elbow to the bottom of the sewer main.

2.17 EXCAVATION AND BACKFILL MATERIAL

Comply with [Section 3010](#) for bedding and backfill materials.

PART 3 - EXECUTION**3.01 GENERAL REQUIREMENTS FOR INSTALLATION OF MANHOLES AND INTAKES**

- A. Excavation:** Excavate according to [Section 3010](#).
- B. Subgrade Preparation:**
- 1. Cut Sections (Undisturbed Soil):** Prepare subgrade to accurate elevation required to place subbase.
 - 2. Fill Sections:** Compact to 95% of maximum Standard Proctor Density and hand grade to accurate elevation required to place subbase, or install stabilization material as directed by the Engineer.
 - 3. Unstable Soil:** Install stabilization material as directed by the Engineer.
- C. Subbase:** Install 8 inch thick pad of Class I bedding material a minimum of 12 inches outside footprint of the structure.
- D. Installation of Manhole or Intake Structure:** When necessary, adjust wall height and depth of base to provide a minimum of 48 inches between form grade elevation and top of base. Form walls and construction joints for cast-in-place intakes or install precast intake boxes to ensure intake lids are set to match the longitudinal slope of the adjacent street unless otherwise specified in the contract documents.
- 1. Cast-in-place:** Comply with Section 6010, 3.02.
 - 2. Precast:** Comply with Section 6010, 3.03.
- E. Pipes:** Install and bed pipes and connect to manhole or intake. Install pipe flush with inside wall of structure. Place bedding and pipe embedment material according to [Section 3010](#).
- 1. Cast-in-place Structures:**
 - a. Storm:** Form structure walls around pipe.
 - b. Sanitary:** Form or core circular opening and install flexible, watertight gasket according to Section 6010, 2.08. Keep void between pipe and manhole section free of debris and concrete.
 - 2. Precast Storm Sewer Manholes or Intakes:** If annular space between pipe and structure is less than 2 inches, fill with non-shrink grout. If annular space is 2 inches or greater, construct a concrete collar around the pipe according to Section 6010, 3.05.
 - 3. Precast Sanitary Sewer Manholes:** Connect to structure with flexible, watertight gasket according to Section 6010, 2.08. Keep void between pipe and manhole section free of debris and concrete.
 - 4. Sanitary Sewer Manholes on Existing Pipe:** Install waterstop according to Section 6010, 2.08.
- F. Joint Sealant:**
- 1. Sanitary Sewer Manholes:**
 - a.** Install rubber O-ring or profile gasket (precast structures).
 - b.** Apply bituminous jointing material or butyl sealant wrap to exterior of all sanitary sewer manhole joints.

**3.01 GENERAL REQUIREMENTS FOR INSTALLATION OF MANHOLES AND INTAKES
(Continued)****2. Storm Sewer Manhole and Intakes:**

- a. Apply bituminous jointing material or install rubber rope gasket.
- b. If indicated in the contract documents, apply engineering fabric wrap to joints.

G. Fillet:

1. Construct manhole or intake fillet up to one-half of pipe diameter to produce a smooth half-pipe shape between pipe inverts.
2. Slope fillet top toward pipe 1/2 inch per foot perpendicular to flow line.
3. For sanitary sewer, keep void between pipe and structure wall free of debris and concrete.
4. For precast fillets, remove any projections and repair any voids to provide a hydraulically smooth channel between ends of pipes.

H. Top Sections: Install manhole eccentric cone or flat top section or install intake top.**I. Adjustment Ring(s):**

1. Bed each concrete ring with bituminous jointing material in trowelable or rope form.
2. Bed each polyethylene or expanded polypropylene ring with manufacturer's approved product and according to manufacturer's recommended installation procedure.
3. Construct manholes and intakes with the following adjustment ring stack heights:
 - a. Minimum: 4 inches for new manholes and intakes. No minimum for rehabilitation projects.
 - b. Maximum: 12 inches for new manholes and intakes; 16 inches for existing manholes and intakes.
4. For greater adjustment, modify lower riser section(s).

J. Casting:

1. Install the type of casting specified in the contract documents and adjust to proper grade.
2. Where a manhole or intake is to be in a paved area, adjust the casting to match the slope of the finished surface.
3. Three-piece Castings:
 - a. Attach the frame to the structure with four anchor bolts.
 - b. Set initial position of movable portion of the casting in the center of the adjustment range.
 - c. Remove height-adjustment bolts or mechanism after the paving is completed.

**3.01 GENERAL REQUIREMENTS FOR INSTALLATION OF MANHOLES AND INTAKES
(Continued)****K. Infiltration Barrier:** Install on sanitary sewer manholes.**1. Internal or External Chimney Seal:**

- a. Do not use external chimney seal if seal will be permanently exposed to sunlight.
- b. Extend seal 3 inches below the lowest adjustment ring.
- c. Extend seal to 2 inches above the flange of the casting for a standard two-piece casting, or 2 inches above the top of the base section of the casting for an adjustable three-piece casting.
- d. Use multiple seals, if necessary.
- e. Install compression bands (external chimney seal) or expansion bands (internal chimney seal) to lock the rubber sleeve or extension into place and to provide a positive watertight seal. Once tightened, lock the bands into place. Use only manufacturer recommended installation tools and sealants.

2. Molded Shield:

- a. Clean surface of structure cone section.
- b. Apply sealant to the top surface of the cone section. Use sufficient sealant to accommodate flaws in the surface of the cone section.
- c. Cut molded shield to height by adding the dimensions of the adjustment rings and casting height. Be sure not to interfere with seating of the lid into the casting frame.
- d. Seat the molded shield against the sealant on the cone section.
- e. Add adjustment rings and casting to meet final grade.

3. Heat Shrink Sleeve:

- a. Ensure all surfaces are clean, dry, and free of foreign objects and sharp edges.
- b. Warm the surface to drive off any moisture.
- c. Cut sleeve to required length per manufacturer's requirements.
- d. Apply primer to manhole and casting surface.
- e. Place sleeve according to manufacturer's requirements.
- f. Apply heat to the sleeve, smooth out wrinkles, and remove trapped air.
- g. Cut the sleeve at the casting gussets. Reheat to place the sleeve onto the casting.
- h. Trim off any excess material.

L. Backfill and Compaction:

1. Place suitable backfill material after concrete in structure has reached at least 3,000 psi compressive strength or 550 psi flexural strength. If concrete strength is not determined, place backfill at least 14 calendar days after initial concrete placement.
2. Place backfill material simultaneously on all sides of walls and structures so the fill is kept at approximately the same elevation at all times.
3. Compact the 3 feet closest to all walls using pneumatic or hand tampers only. Ensure proper and uniform compaction of backfill around structure.

3.02 ADDITIONAL REQUIREMENTS FOR CAST-IN-PLACE CONCRETE STRUCTURES**A. Forms:**

1. Comply with [Iowa DOT Article 2403.03, B](#).
2. Form all cast-in-place manholes and intakes on both the inside and the outside face above the base. Do not form against excavated earthen surface.

**3.02 ADDITIONAL REQUIREMENTS FOR CAST-IN-PLACE CONCRETE STRUCTURES
(Continued)****B. Reinforcing Steel:**

1. Comply with [Iowa DOT Section 2404](#).
2. Lap bars a minimum of 36 diameters, unless otherwise specified in the contract documents.
3. Provide a minimum of 3 inches of clearance for structure bases and 2 inches of clearance for walls and tops.

C. Concrete Mixing:

1. Comply with [Iowa DOT Article 2403.02, D](#).
2. When using ready-mixed concrete, comply with ASTM C 94.

D. Concrete Placing:

1. Comply with [Iowa DOT Article 2403.03, C](#).
2. Do not place concrete when the air temperature is less than 40°F without the approval of the Engineer. When placement of concrete below 40°F is allowed, comply with [Iowa DOT Article 2403.03, F](#).
3. Place concrete continuously in each section until complete. Do not allow more than 30 minutes to elapse between depositing adjacent layers of concrete within each section.
4. Comply with [Iowa DOT Article 2403.03, D](#) for concrete vibration.
5. Form 1 1/2 inch by 3 inch keyed construction joints at locations shown in the contract documents.
6. Provide a broom finish on portions of structure that are to become part of exposed pavement.

E. Stripping and Cleaning:

1. Remove forms for manhole and intake walls and tops according to [Iowa DOT Article 2403.03, M](#). References to culverts include all sanitary and storm structures. When allowed by the Engineer, compressive strengths at six times the stated flexural strengths may be used in determining concrete strength of structure tops.
2. Finish surfaces according to [Iowa DOT Article 2403.03, P](#). Give exposed surfaces a Class 2 finish.

F. Curing:

1. Comply with [Iowa DOT Article 2403.03, E](#).
2. For surfaces visible to the public, use only curing compounds complying with ASTM C 309, Type 1-D or Type 2.

**3.02 ADDITIONAL REQUIREMENTS FOR CAST-IN-PLACE CONCRETE STRUCTURES
(Continued)****G. Exterior Loading:**

1. Restrict exterior loads on concrete according to [Iowa DOT Article 2403.03, N.](#)
2. When allowed by the Engineer, compressive strengths at six times the stated flexural strengths may be used.

H. Repairs: After visual inspection of the completed manhole or intake, repair honeycomb areas, visible leaks, tie holes, or other damaged areas. Remove concrete webs or protrusions.

I. Concrete Testing: The Engineer will conduct testing.

3.03 ADDITIONAL REQUIREMENTS FOR PRECAST CONCRETE STRUCTURES

A. Substitutions: If approved by the Engineer, precast structures may be substituted for designated cast-in-place structures. Comply with the requirements of Section 6010, 3.02 or [Iowa DOT Materials I.M. 445.](#)

B. Cast-in-place Base:

1. Comply with Section 6010, 3.02 for placement of concrete.
2. Ensure proper vertical and horizontal alignment of base riser section.

C. Precast Base or Base with Integral Riser Section: Place base or base with integral riser section and ensure proper vertical and horizontal alignment.

D. Additional Riser Sections: Install additional riser sections as required.

E. Lift Holes: Install rubber plug in lift holes. Cover plug and hole with non-shrink grout.

3.04 ADJUSTMENT OF EXISTING MANHOLE OR INTAKE**A. Casting Extension Rings:**

1. Install casting extension rings only when specified in the contract documents, and only in conjunction with pavement overlays.
2. Install according to the manufacturer's recommendation and adjust for proper alignment.

B. Minor Adjustment (Adding or Removing Adjustment Rings):

1. Remove casting.
2. Modify adjustment ring stack height by one of the following methods:
 - a. Add adjustment rings as necessary to adjust existing manhole or intake to finished pavement grade or finished topsoil grade, to a maximum ring stack height of 16 inches. Bed each concrete ring with bituminous jointing material. Bed each polyethylene ring with manufacturer's approved product.
 - b. Remove one or more adjustment rings, as appropriate, to reduce casting elevation.
3. Install new casting on modified adjustment ring stack. Existing casting may be reinstalled when specified in the contract documents.

3.04 ADJUSTMENT OF EXISTING MANHOLE OR INTAKE (Continued)

4. Replace infiltration barrier for sanitary sewer manhole using only new materials.

C. Major Adjustment (Adding, Removing, or Modifying Riser or Cone Section): When adjustment is greater than can be accomplished through adding or removing adjustment rings, a major adjustment will be required.

1. Remove casting.
2. Remove top.
3. Remove and replace or modify existing riser section and/or top section according to the method approved by the Engineer.
4. Install new frame and cover or grate. Existing casting may be reinstalled when specified in the contract documents.
5. Replace infiltration barrier for sanitary sewer manhole using only new materials.

3.05 CONNECTION TO EXISTING MANHOLE OR INTAKE**A. General:**

1. Remove existing fillet as necessary to install pipe at required elevation and develop hydraulic channel.
2. Insert pipe into structure and trim end flush with inside wall of structure.
3. Install replacement fillet as necessary.
4. Place backfill material according to [Section 3010](#).

B. Concrete Collar:

1. For new pipes 12 inches or smaller, install two number 4 steel reinforcing hoops in collar around pipe. Pour concrete collar around pipe/structure junction to a minimum thickness and width of 6 inches, providing a minimum of 4 inches of concrete extending beyond the pipe opening.
2. For new pipes larger than 12 inches, install two number 4 steel reinforcing hoops in collar around pipe. Pour concrete collar around pipe/structure junction to minimum thickness and width of 9 inches, providing a minimum of 4 inches of concrete extending beyond the pipe opening.

C. Sanitary Sewer:**1. General:**

- a. Core new openings in existing manholes unless otherwise specified in the contract documents.
- b. Divert flow as necessary. Obtain approval of the diversion plan from the Engineer. Maintain sanitary sewer service at all times unless otherwise specified in the contract documents.

2. Cored Opening:

- a. Insert flexible watertight connector into new opening.
- b. Install and tighten internal expansion sleeve to hold flexible connector in place.
- c. Insert pipe through flexible connector and tighten external compression ring.
- d. Do not install grout or concrete collar for cored opening with flexible connector.

3.05 CONNECTION TO EXISTING MANHOLE OR INTAKE (Continued)

- 3. Cut and Chipped Opening (Knock-out):** Use only when specified or allowed.
 - a. Saw opening to approximate dimensions with a masonry saw. Saw to depth sufficient to sever reinforcing steel.
 - b. Remove concrete and expand opening to a diameter at least 6 inches larger than the outside diameter of the new pipe.
 - c. Cut off all reinforcing steel protruding from the structure wall.
 - d. Install waterstop around new pipe centered within structure wall.
 - e. Fill opening between structure and pipe with non-shrink grout.
 - f. Construct concrete collar around pipe and exterior manhole opening.
 - g. Provide pipe joint, non-shear coupling, or other approved flexible coupling within 2 feet of structure wall to allow for differential settlement between the new sewer and the structure.

D. Storm Sewer:

- 1. Cut and Chipped Opening:**
 - a. Use for pipe sizes 12 inches in diameter or larger.
 - b. Saw opening to approximate dimensions with a masonry saw. Saw to depth sufficient to sever reinforcing steel.
 - c. Remove concrete and expand opening to a diameter at no more than 4 inches larger than the outside diameter of the new pipe.
 - d. Leave a minimum of 6 inches of manhole or intake wall above and on the sides of the pipe.
 - e. Cut off all reinforcing steel protruding from the structure wall.
- 2. Cored Opening:**
 - a. Core new openings in existing manholes or intakes for all pipes less than 12 inches in diameter.
 - b. Opening to be no greater than 2 inches larger than the outside diameter of the pipe.
 - c. Leave a minimum of 6 inches of manhole or intake wall above and on the sides of the pipe.
- 3. Fill Opening:** Fill opening between manhole or intake wall and outside of pipe with non-shrink grout or construct a concrete collar around the pipe according to Section 6010, 3.05, B.

3.06 DROP CONNECTION TO SANITARY SEWER MANHOLE**A. Internal:**

1. Core opening in existing manhole wall and install flexible watertight connector.
2. Cut incoming pipe so a maximum of 2 inches extends into the manhole.
3. Allow 1 inch clearance between bottom of incoming pipe and top of the receiving bowl. Connect receiving bowl to manhole with stainless steel anchor bolts as recommended by the manufacturer.
4. Install flexible coupler connecting the receiving bowl and the drop pipe.
5. Mount drop pipe on the side of the manhole with stainless steel brackets spaced a maximum of 4 feet apart. Provide a minimum of two brackets per pipe segment.
6. Remove existing concrete fillet as required to accommodate bottom elbow.

3.06 DROP CONNECTION TO SANITARY SEWER MANHOLE (Continued)

7. Install elbow at bottom of drop pipe to match concrete fillet and create a smooth flow transition. Align elbow so discharge is directed at outlet pipe or at 45 degrees to manhole flow.
8. Repair fillet according to Section 6010, 3.01, G.
9. Comply with [Figure 6010.308](#).

B. External:

1. Core opening in existing manhole wall and install flexible watertight connector, if required.
2. Install ductile iron pipe and fittings according to [Section 5010, 3.01](#) and [3.02](#).
3. Place concrete from the base of the manhole to the top of the elbow.
4. Comply with [Section 3010, 3.05](#) for bedding and backfill of the external drop piping.
5. Comply with [Figure 6010.307](#).

3.07 REMOVAL OF MANHOLE OR INTAKE

- A. Unless otherwise specified, remove the entire structure to a minimum of 10 feet below top of subgrade in paved areas or 10 feet below finished grade in other areas.
- B. Pipes:
 1. Contact the Engineer to verify the sewer line is not in use.
 2. Construct sewer plug by completely filling the end of the pipe with concrete. Force concrete into the end of the pipe for a distance of 16 inches, or one-half the pipe diameter, whichever is greater.
 3. If specified in the contract documents, fill the line to be abandoned with flowable mortar or CLSM (comply with [Section 3010](#)) by gravity flow or pumping.
- C. Fill remaining structure using flowable mortar.
- D. Place compacted backfill over remaining structure as required for embankment or compacted backfill.

3.08 CLEANING, INSPECTION, AND TESTING

Clean, inspect, and test structures according to [Section 6030](#).

END OF SECTION

If manhole depth exceeds 20 feet, install steps.

Install infiltration barrier.

- ① For additional configurations, maintain a minimum of 12 inches of concrete between vertical edges of pipe openings.
- ② 12 inch minimum riser height above all pipe openings.
- ③ When specified, provide an eccentric flat top In Lieu of eccentric cone section.

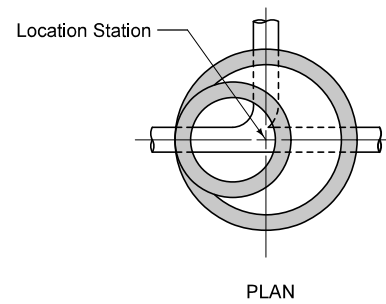
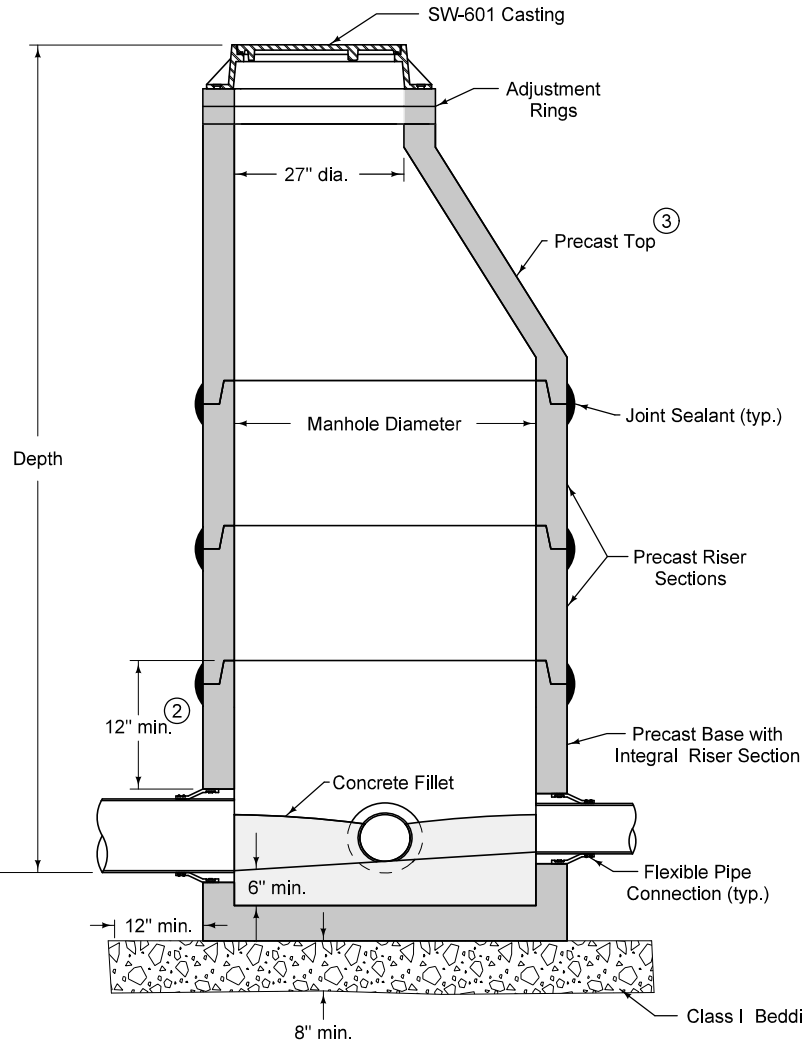

Manhole Diameter (inches)	Maximum Pipe Diameter (inches) for 2 Pipes ①	
	At 180° Separation	At 90° Separation
48	24	18
60	36	24
72	42	30
84	48	36
96	60	42

TYPICAL SECTION

SUDAS	IOWADOT	REVISION
		5 10-18-22
FIGURE 6010.301	STANDARD ROAD PLAN	SW-301
		SHEET 1 of 1
REVISIONS: Added circle note 3.		
Paul D. Wigand SUDAS DIRECTOR		Stuart Miller DESIGN METHODS ENGINEER
CIRCULAR SANITARY SEWER MANHOLE		

FIGURE 6010.301 SHEET 1 OF 1

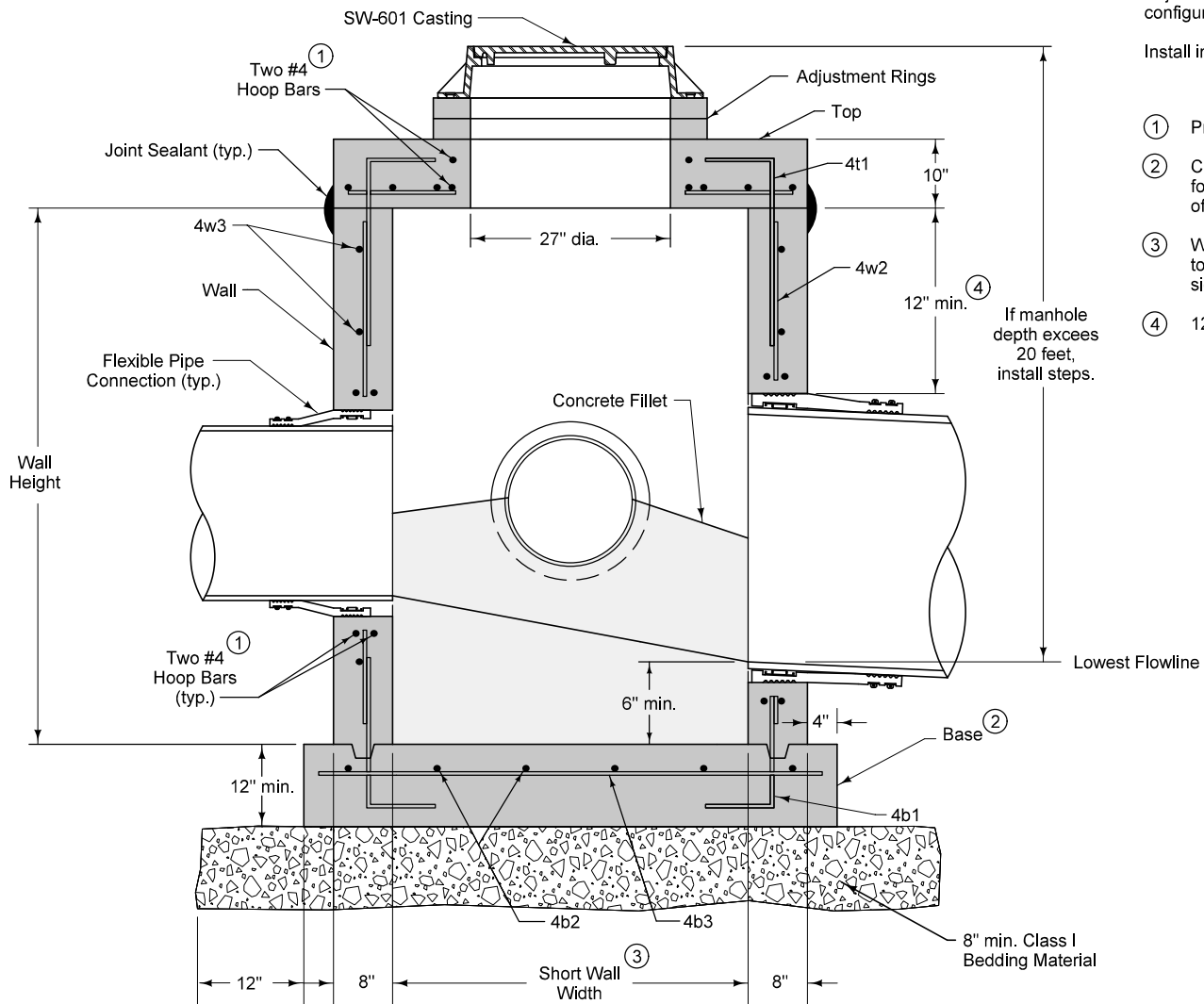

TYPICAL SECTION

Adjacent walls may have different widths based upon pipe configuration, but structure must be rectangular.

Install infiltration barrier.

- ① Provide two #4 hoop bars at top opening and at all pipe openings.
- ② Cast-in-place base shown. If base is precast integral with walls, the footprint of the base is not required to extend beyond the outer edge of the walls.
- ③ Wall widths vary with pipe diameter and range from 4 feet minimum to 9 feet maximum. Provide 12 inches of wall width (minimum) each side of pipe opening.
- ④ 12 inch minimum wall height above all pipe openings.

If manhole depth exceeds 20 feet, install steps.

FIGURE 6010.302 SHEET 1 OF 2

SUDAS	IOWADOT	REVISION
		3 04-20-21
FIGURE 6010.302	STANDARD ROAD PLAN	SW-302
REVISIONS: Added infiltration barrier note.		SHEET 1 of 2
Paul D. Wigand SUDAS DIRECTOR		Stuart Miller DESIGN METHODS ENGINEER
RECTANGULAR SANITARY SEWER MANHOLE		

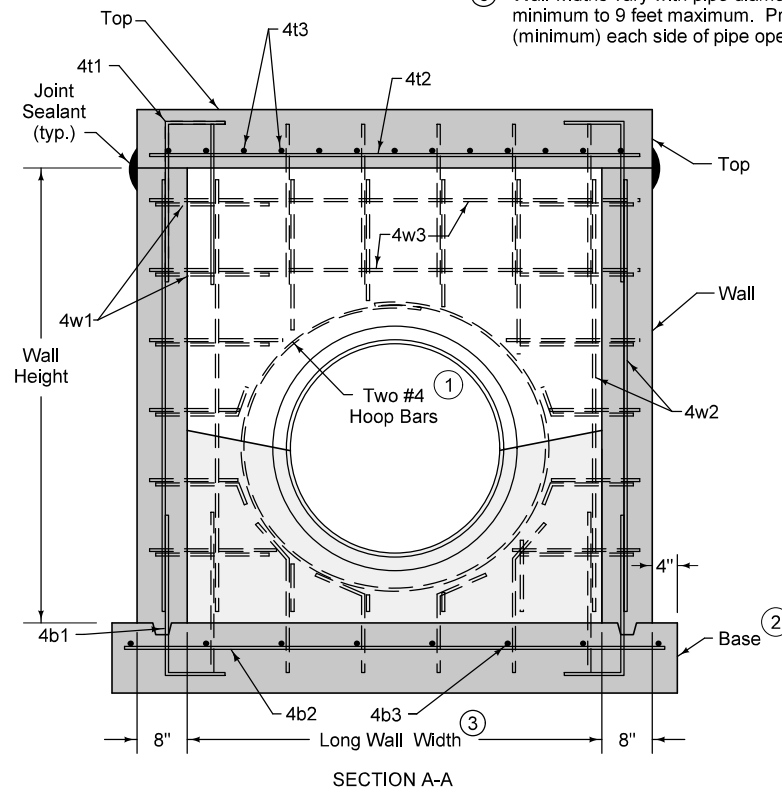
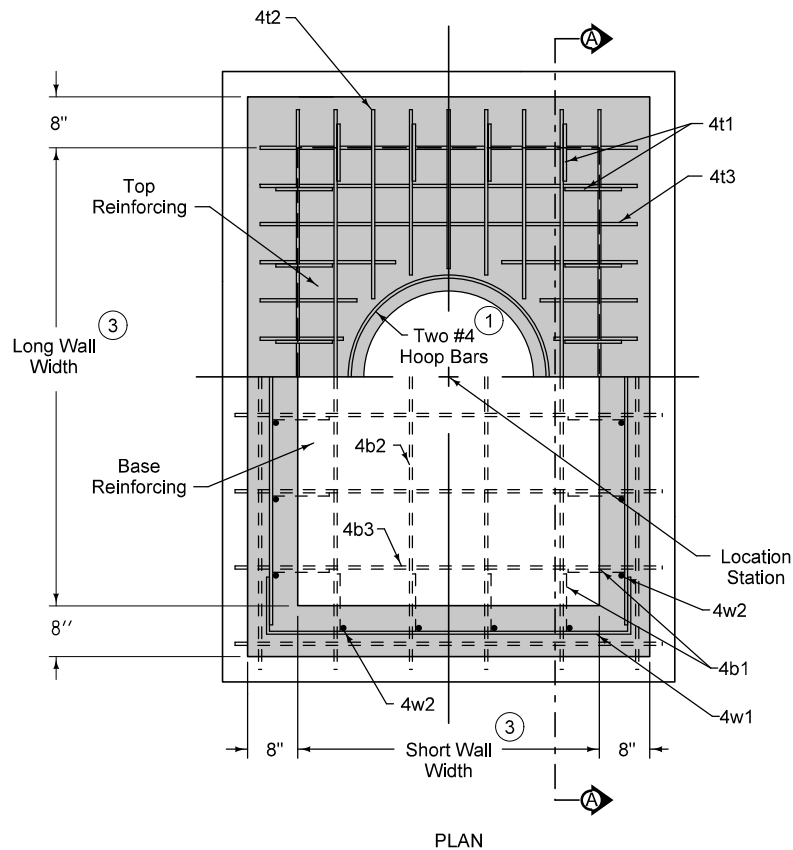

- ① Provide two #4 hoop bars at top opening and at all pipe openings.
- ② Cast-in-place base shown. If base is precast integral with walls, the footprint of the base is not required to extend beyond the outer edge of the walls.
- ③ Wall widths vary with pipe diameter and range from 4 feet minimum to 9 feet maximum. Provide 12 inches of wall width (minimum) each side of pipe opening.

PLAN

SECTION A-A

REINFORCING BAR LIST

Mark	Size	Location	Shape	Length	Spacing
4b1	4	Base	└	36"	12"
4b2	4	Base	—	Long Wall plus 18"	12"
4b3	4	Base	—	Short Wall plus 18"	12"
4t1	4	Top	┌	36"	12"
4t2	4	Top	—	Long Wall plus 12"	6"
4t3	4	Top	—	Short Wall plus 12"	6"
4w1	4	Wall	┌└	Short Wall plus 48"	12"
4w2	4	Wall	—	Wall Height minus 4"	12"
4w3	4	Wall	—	Long Wall plus 12"	12"

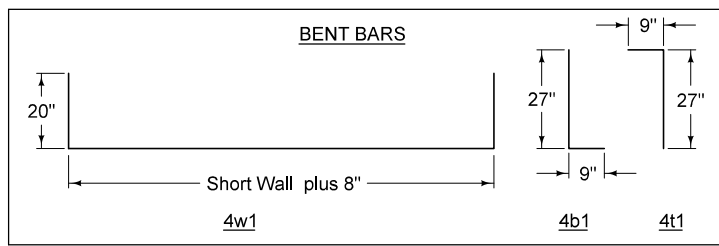
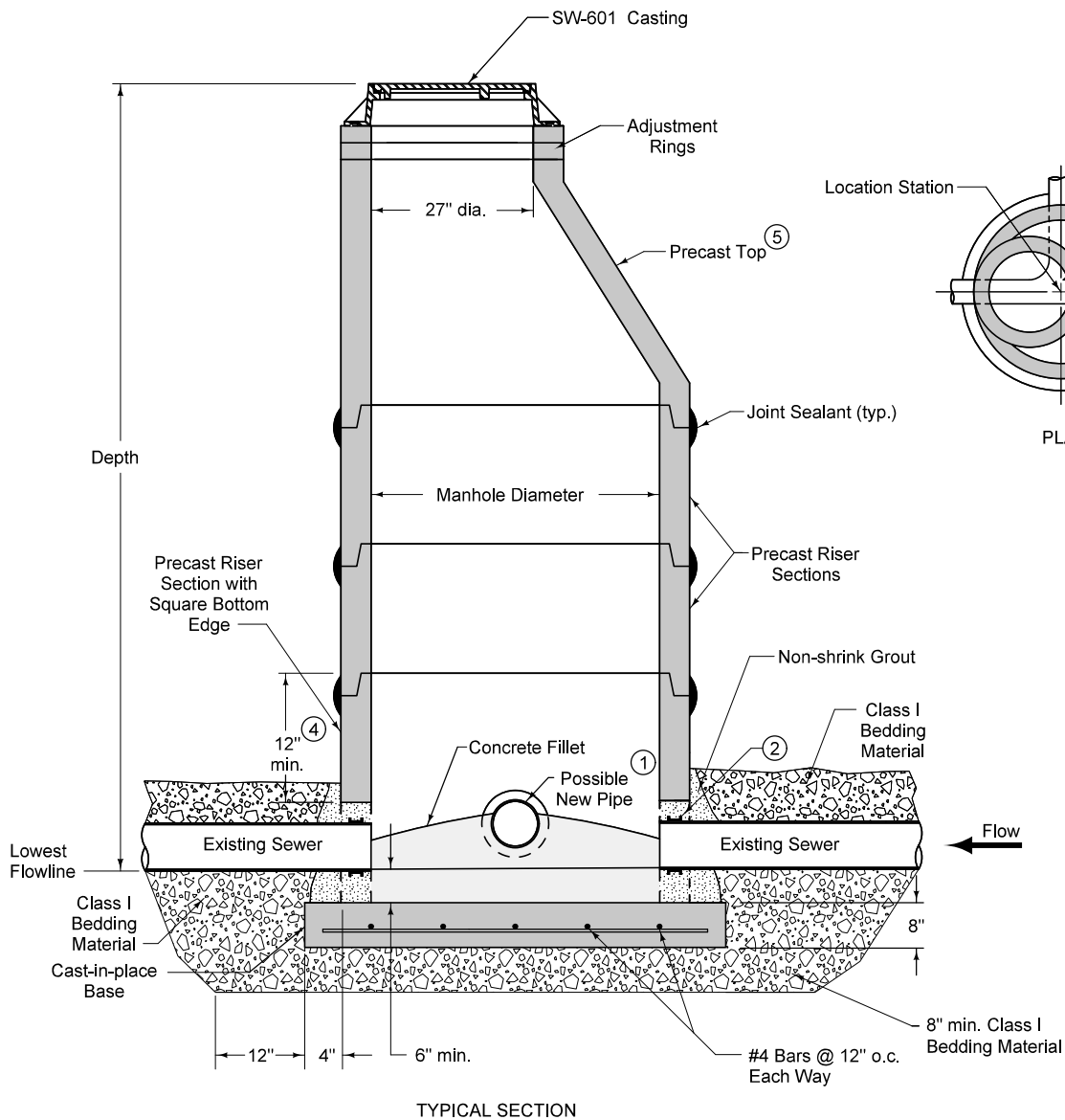

FIGURE 6010.302 SHEET 2 OF 2

SUDAS IOWADOT	REVISION 3 04-20-21
	FIGURE 6010.302 STANDARD ROAD PLAN SW-302 SHEET 2 of 2
REVISIONS: Added infiltration barrier note.	
Paul D. Wigand SUDAS DIRECTOR Stuart M. Nadeau DESIGN METHODS ENGINEER	
RECTANGULAR SANITARY SEWER MANHOLE	



If manhole depth exceeds 20 feet, install steps.
 Install infiltration barrier.

- ① For new pipe connections, provide cored opening with flexible pipe connector.
- ② For existing pipe connections, provide an arched opening with a diameter up to 6 inches larger than outside diameter of pipe. Install waterstop around existing pipe. Fill void between pipe and opening with non-shrink grout.
- ③ For additional configurations, maintain a minimum of 12 inches of concrete between vertical edges of pipe openings.
- ④ 12 inch minimum riser height above all pipe openings.
- ⑤ When specified, provide an eccentric flat to In Lieu of eccentric cone section.

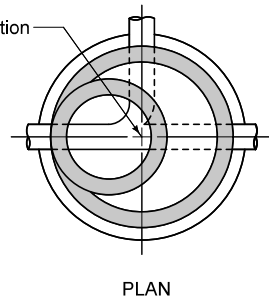

Manhole Diameter (inches)	Maximum Pipe Diameter (inches) for 2 Pipes ③	
	At 180° Separation	At 90° Separation
48	24	18
60	36	24
72	42	30
84	48	36
96	60	42

FIGURE 6010.303 SHEET 1 OF 1

		REVISION
		5 10-18-22
FIGURE 6010.303	STANDARD ROAD PLAN	SW-303
REVISIONS: Added circle note 5.		SHEET 1 of 1
 SUDAS DIRECTOR		 DESIGN METHODS ENGINEER
SANITARY SEWER MANHOLE OVER EXISTING SEWER		

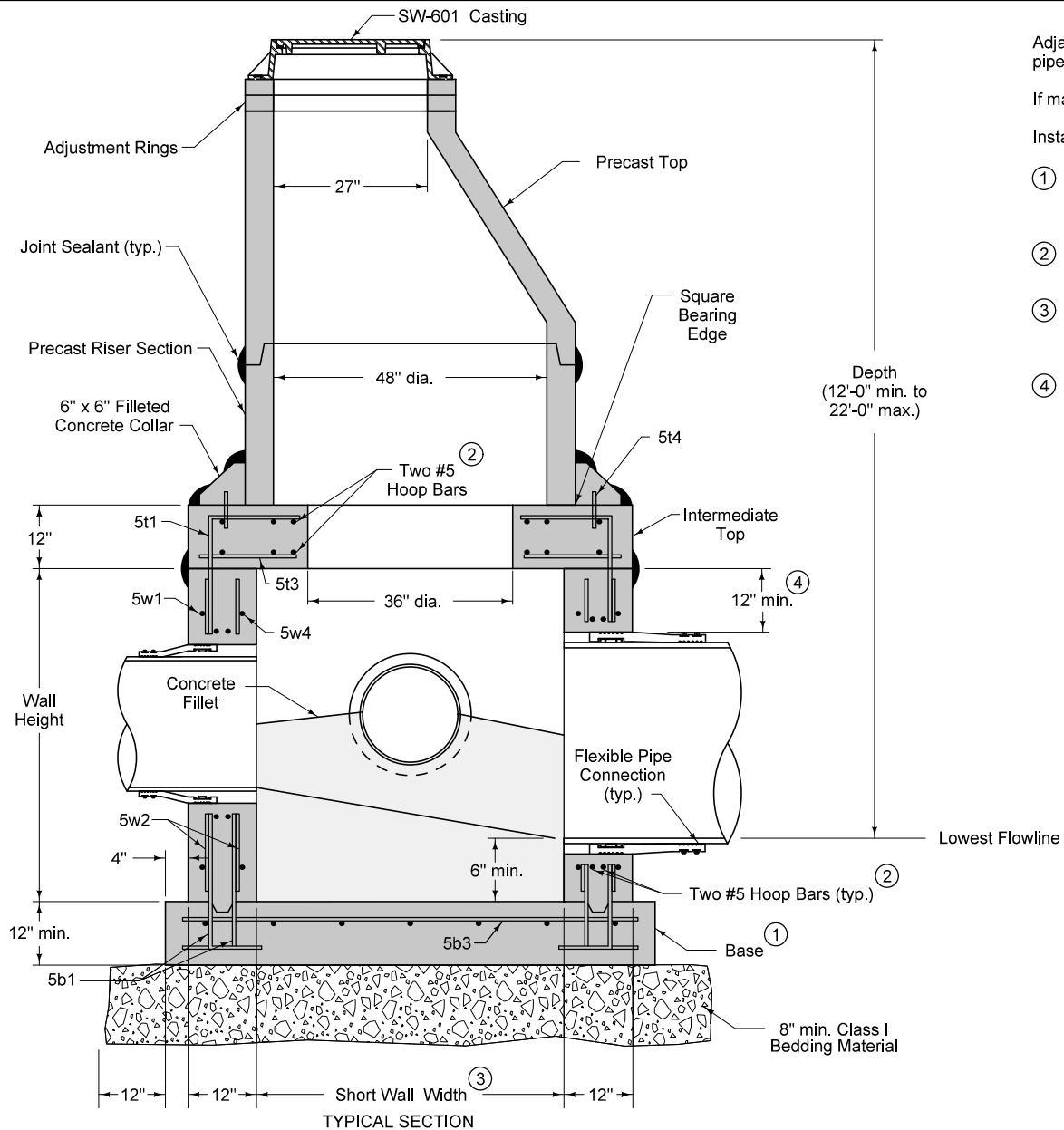

Adjacent walls may have different widths based upon pipe configuration, but structure must be rectangular.

If manhole depth exceeds 20 feet, install steps.

Install infiltration barrier.

- ① Cast-in-place base shown. If base is precast integral with walls, the footprint of the base is not required to extend beyond the outer edge of the walls.
- ② Provide two #5 hoop bars at intermediate top opening and at all pipe openings.
- ③ Wall widths vary with pipe diameter and range from 4 feet minimum to 12 feet maximum. Provide 12 inches of wall width (minimum) each side of pipe opening.
- ④ 12 inch minimum wall height above all pipe openings.

FIGURE 6010.304 SHEET 1 OF 2

SUDAS IOWADOT	REVISION	4	04-20-21
	FIGURE 6010.304	STANDARD ROAD PLAN	SW-304
REVISIONS: Added manhole depth note and infiltration barrier note.		SHEET 1 of 2	
Paul D. Wigand SUDAS DIRECTOR		Shawn Miller DESIGN METHODS ENGINEER	
RECTANGULAR BASE/ CIRCULAR TOP SANITARY SEWER MANHOLE			

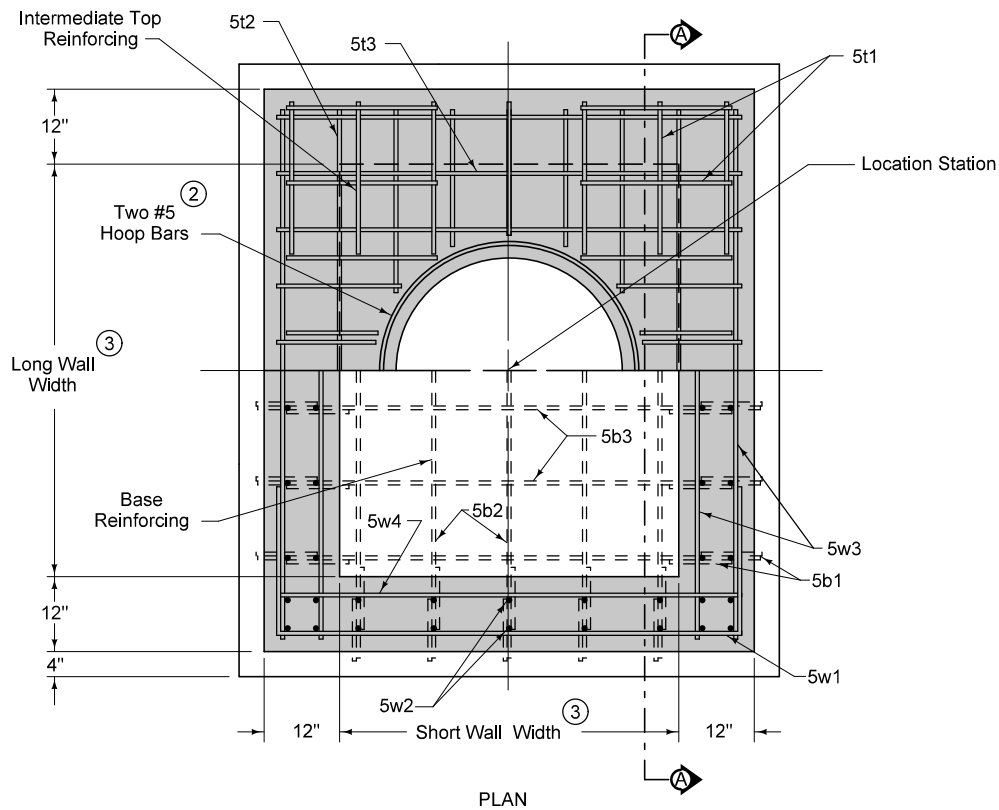

- ② Provide two #5 hoop bars at intermediate top opening and at all pipe openings.
- ③ Wall widths vary with pipe diameter and range from 4 feet minimum to 12 feet maximum. Provide 12 inches of wall opening (minimum) each side of pipe opening.

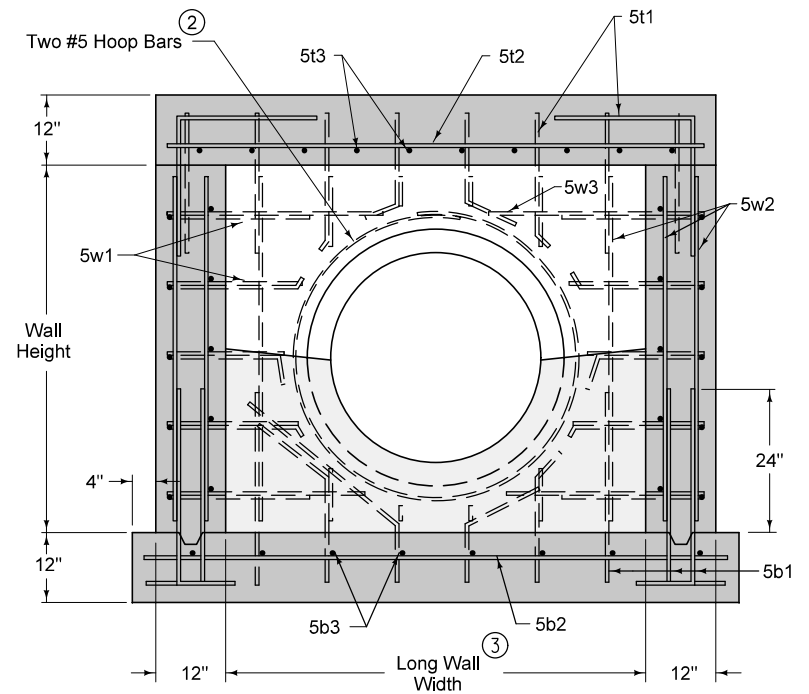

REINFORCING BAR LIST					
Mark	Size	Location	Shape	Length	Spacing
5t1	5	Top	L	48"	12"
5t2	5	Top	—	Long Wall plus 20"	9"
5t3	5	Top	—	Short Wall plus 20"	9"
5t4	5	Top	—	8"	12"
5b1	5	Base	L	43"	12"
5b2	5	Base	—	Long Wall plus 26"	12"
5b3	5	Base	—	Short Wall plus 26"	12"
5w1	5	Top	U	Short Wall plus 68"	12"
5w2	5	Top	—	Wall Height minus 4"	12"
5w3	5	Top	—	Long Wall plus 20"	12"
5w4	5	Top	—	Short Wall plus 20"	12"

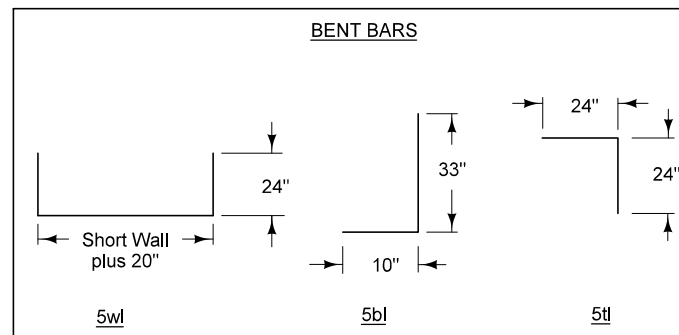

SECTION A-A

SUDAS	IOWADOT	REVISION
		4 04-20-21
FIGURE 6010.304	STANDARD ROAD PLAN	SW-304
REVISIONS: Added manhole depth note and infiltration barrier note.		SHEET 2 of 2
Paul D. Weigand SUDAS DIRECTOR		Shawn Nadeau DESIGN METHODS ENGINEER
RECTANGULAR BASE/ CIRCULAR TOP SANITARY SEWER MANHOLE		

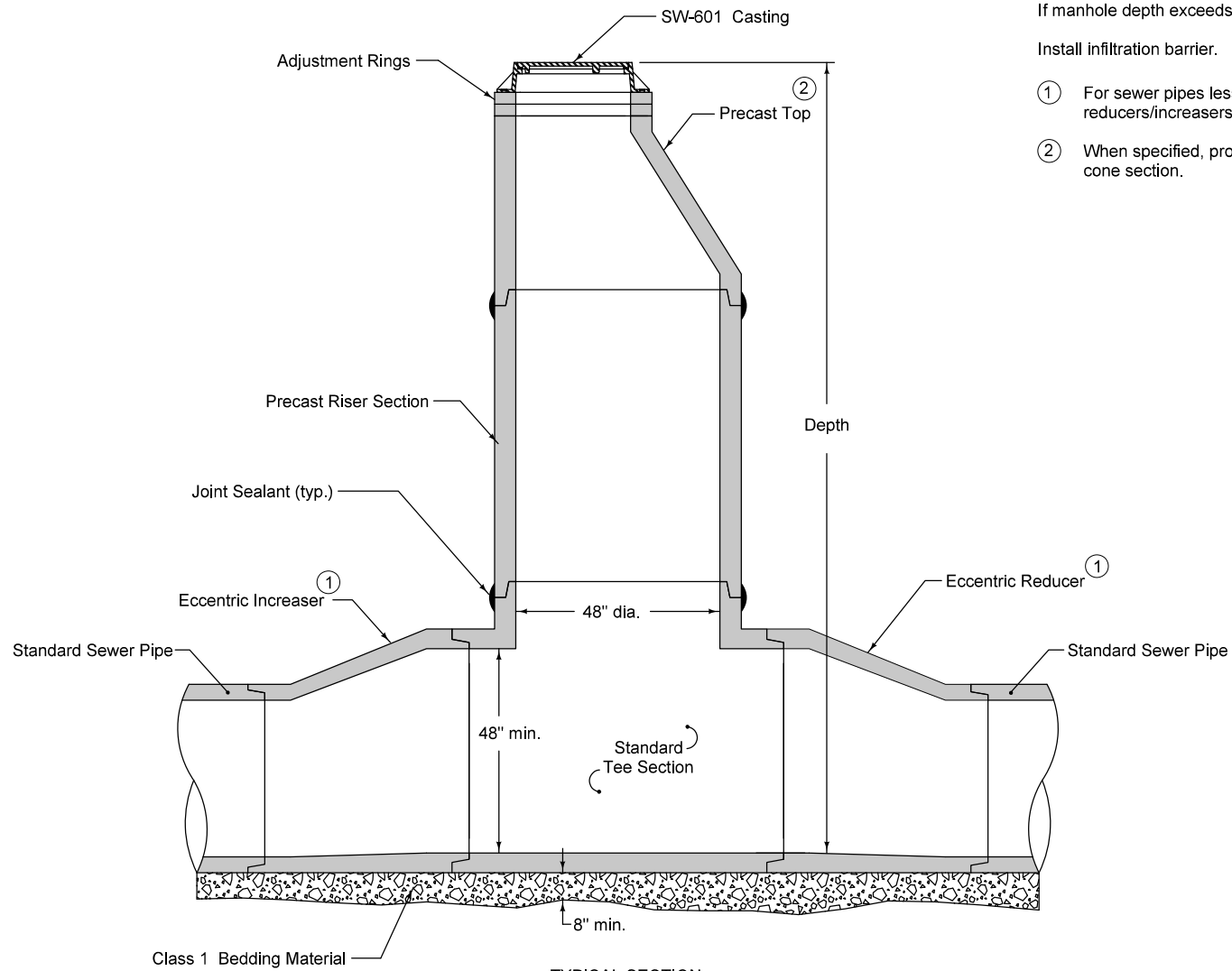

If manhole depth exceeds 20 feet, install steps.

Install infiltration barrier.

- ① For sewer pipes less than 48 inches in diameter, install eccentric reducers/increasers with a standard tee or utilize a composite tee.
- ② When specified, provide an eccentric flat top in lieu of eccentric cone section.

TYPICAL SECTION

STANDARD TEE ①

FIGURE 6010.305 | SHEET 1 OF 2

SUDAS	IOWADOT	REVISION
		4 10-18-22
FIGURE 6010.305	STANDARD ROAD PLAN	SW-305
		SHEET 1 of 2
REVISIONS: Added circle note 2.		
Paul D. Wigand SUDAS DIRECTOR		Scott Miller DESIGN METHODS ENGINEER
TEE-SECTION SANITARY SEWER MANHOLE		

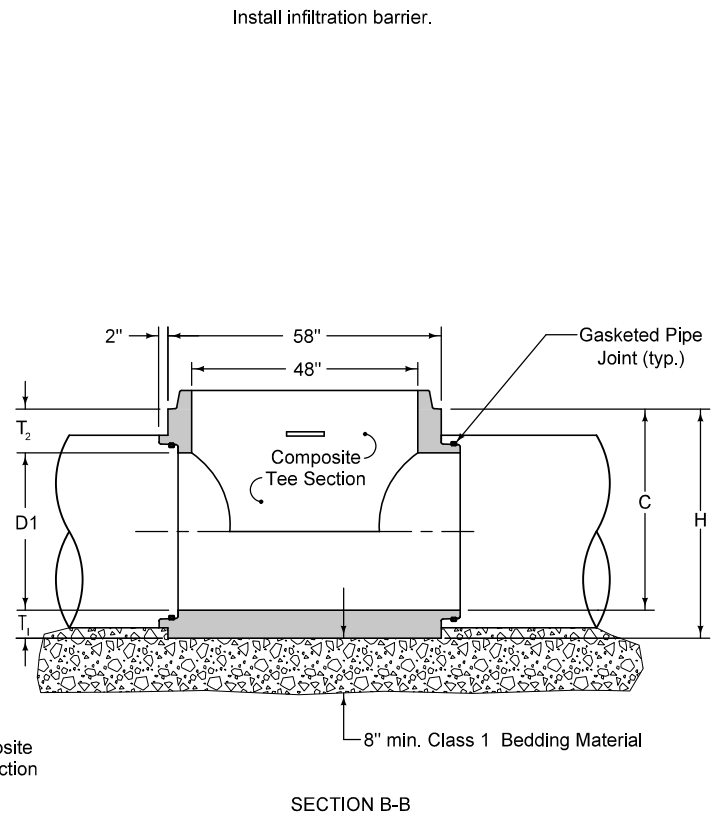
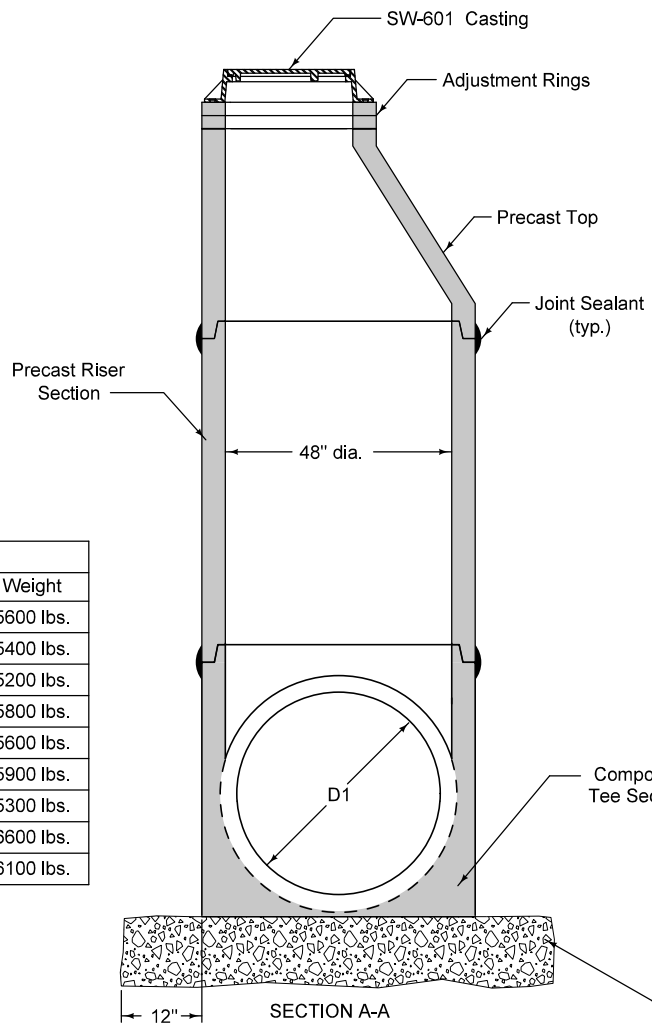
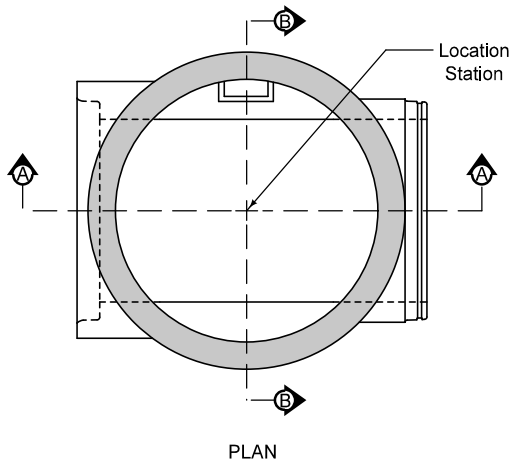

COMPOSITE TEE DIMENSIONS						
Size	D1	H	T ₁	T ₂	C	Weight
48" on 12"	12"	50"	8½"	29½"	41½"	5600 lbs.
48" on 15"	15"	50"	7"	28"	43"	5400 lbs.
48" on 18"	18"	50"	5½"	26½"	44½"	5200 lbs.
48" on 21"	21"	48"	9½"	17½"	38½"	5800 lbs.
48" on 24"	24"	48"	8"	16"	40"	5600 lbs.
48" on 27"	27"	48"	9½"	11½"	38½"	5900 lbs.
48" on 30"	30"	48"	8"	10"	40"	5300 lbs.
48" on 33"	33"	54"	9½"	11½"	44½"	6600 lbs.
48" on 36"	36"	54"	8"	10"	46"	6100 lbs.



COMPOSITE TEE

Alternate to standard tee with eccentric reducer (for pipes 36" and smaller).

SUDAS IOWADOT	REVISION 4 10-18-22
	FIGURE 6010.305 STANDARD ROAD PLAN SW-305 SHEET 2 of 2
REVISIONS: Added circle note 2.	
Paul D. Wigand SUDAS DIRECTOR	
Stuart Miller DESIGN METHODS ENGINEER	
TEE-SECTION SANITARY SEWER MANHOLE	

Figure 6010.306

RESERVED FOR FUTURE USE

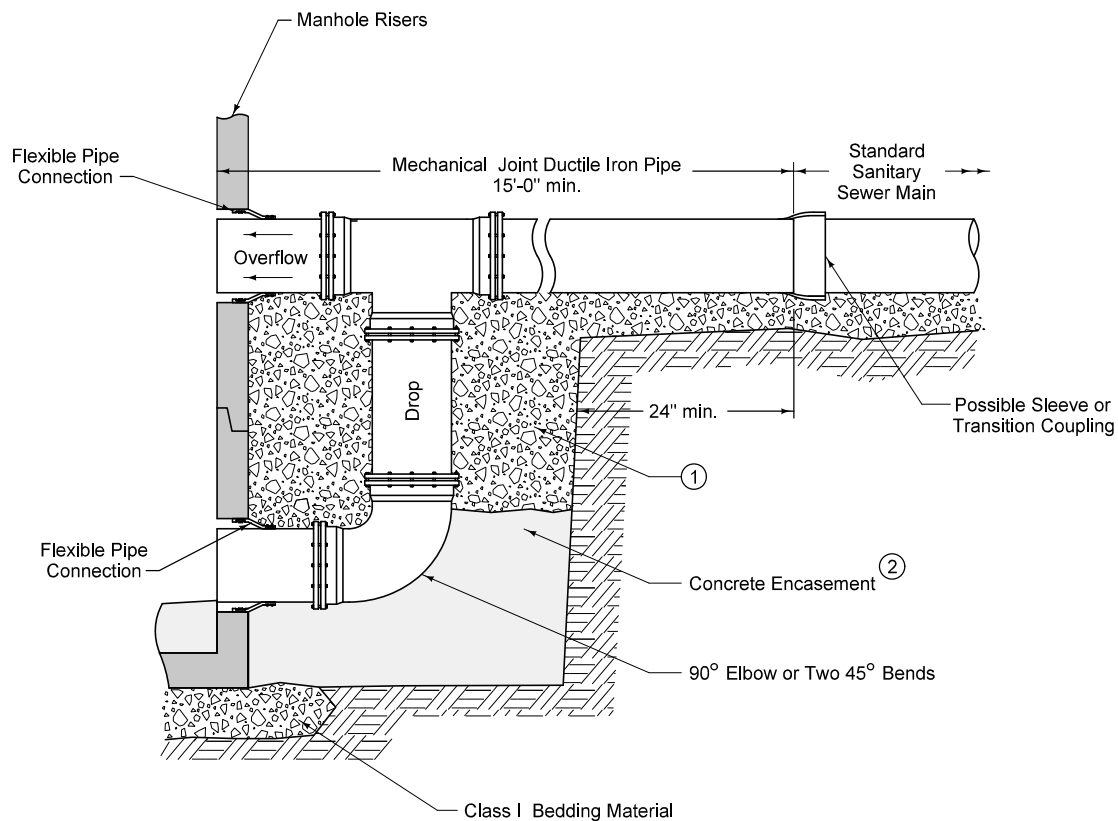

Construct drop and overflow from ductile iron pipe of same diameter specified for sewer main. Provide mechanical joints for all ductile iron pipe and fittings.

- ① Place Class I bedding material, CLSM, flowable mortar, or concrete from top of elbow to bottom of sewer main.
- ② Encase elbow in concrete. 12 inches minimum on all sides.

FIGURE 6010.307 SHEET 1 OF 1

SUDAS	IOWADOT	REVISION
		2 04-21-20
FIGURE 6010.307	STANDARD ROAD PLAN	SW-307
		SHEET 1 of 1
<small>REVISIONS: Changed 1 to 1 on Bedding Material in Note 1. Added EXTERNAL to title.</small>		
Paul D. Wigand SUDAS DIRECTOR		Shawn Nadeau DESIGN METHODS ENGINEER
EXTERNAL DROP CONNECTION FOR SANITARY SEWER MANHOLE		

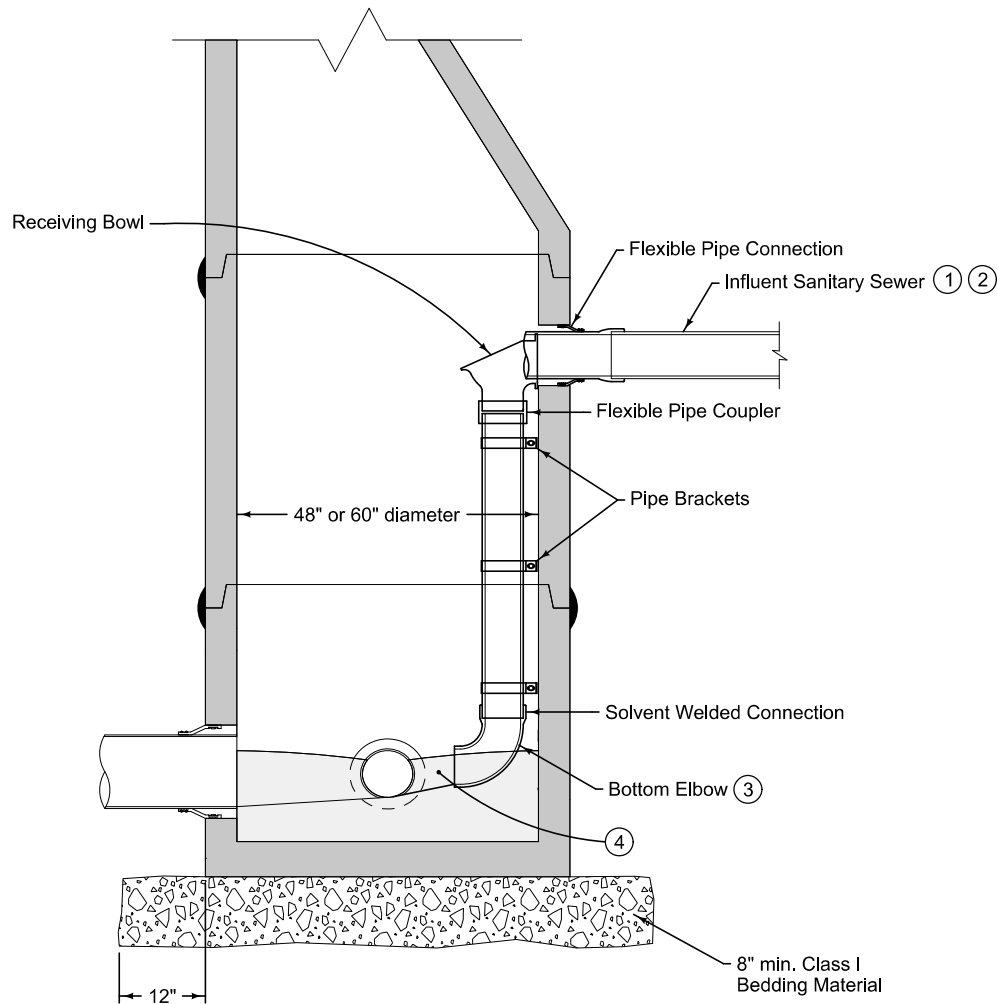

- ① Core drill openings at least 12 inches from existing manhole joints.
- ② Install flexible pipe coupler or pipe joint on new sanitary sewer 18 to 24 inches from outside of manhole wall.
- ③ Align elbow so discharge is directed at outlet pipe or at 45 degrees to manhole flow.
- ④ Reshape fillet to provide a smooth transition and to direct flow to outlet.

SUDAS	IOWADOT	REVISION
		1 04-20-21
FIGURE 6010.308	STANDARD ROAD PLAN	SW-308
		SHEET 1 of 1
REVISIONS: Deleted top of manhole.		
Paul D. Wigand SUDAS DIRECTOR		Shawn Nadeau DESIGN METHODS ENGINEER
INTERNAL DROP CONNECTION FOR SANITARY SEWER MANHOLE		

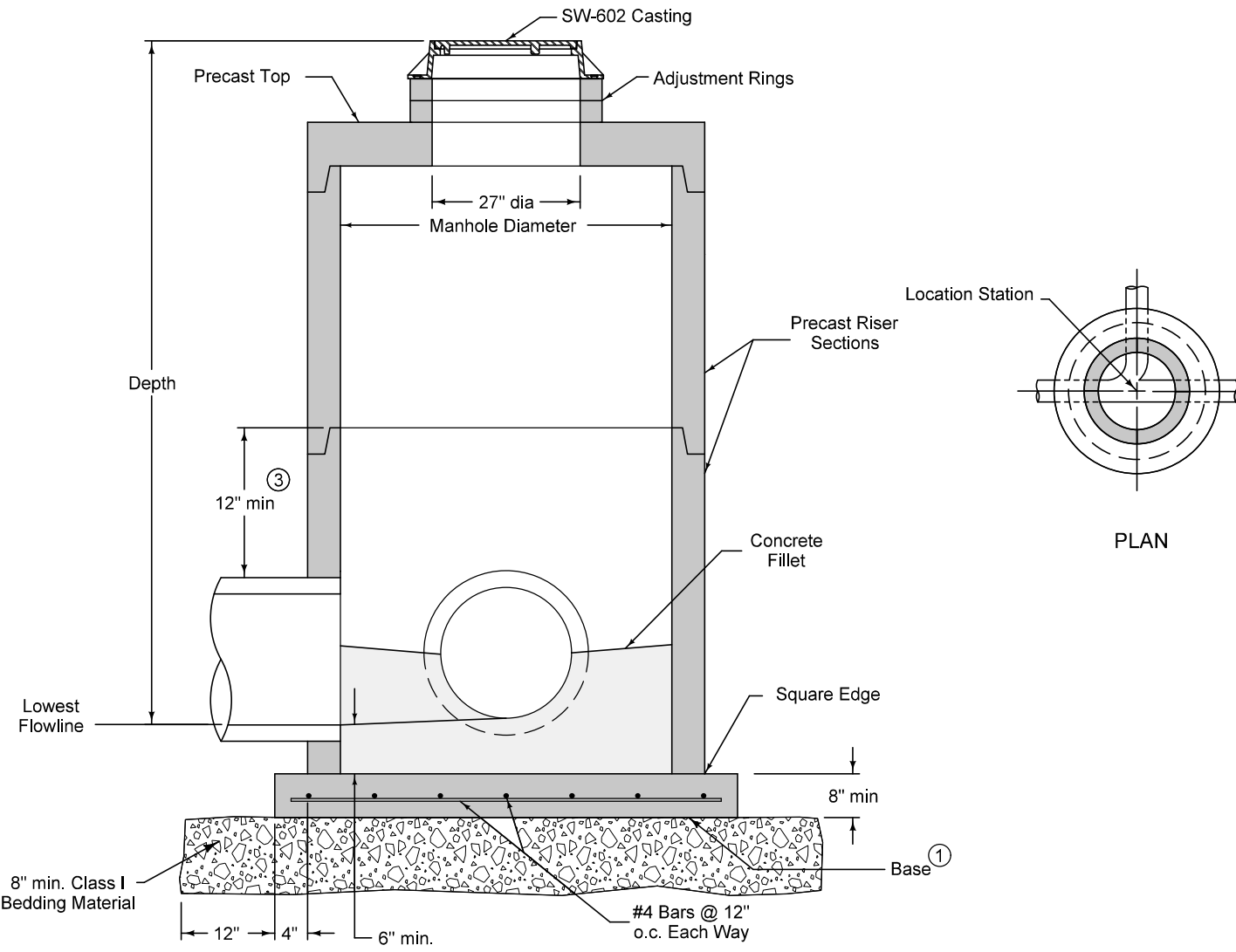

TYPICAL SECTION

If manhole depth exceeds 20 feet, install steps.

- ① Cast-in-place base shown. If base is precast integral with bottom riser, the footprint of the base is not required to extend beyond the outer edge of the riser.
- ② For additional configurations, maintain a minimum of 12 inches of concrete between vertical edges of pipe openings.
- ③ 12 inch minimum riser height above all pipe openings.

Manhole Diameter (inches)	Maximum Pipe Diameter (inches) for 2 Pipes ②	
	At 180° Separation	At 90° Separation
48	24	18
60	36	24
72	42	30
84	48	36
96	60	42

FIGURE 6010.401 SHEET 1 OF 1

SUDAS IOWADOT	REVISION 3 04-20-21
	SW-401 SHEET 1 of 1
FIGURE 6010.401 STANDARD ROAD PLAN	REVISIONS: Added manhole depth note. Paul D. Wigand SUDAS DIRECTOR Mark Nide DESIGN METHODS ENGINEER
CIRCULAR STORM SEWER MANHOLE	

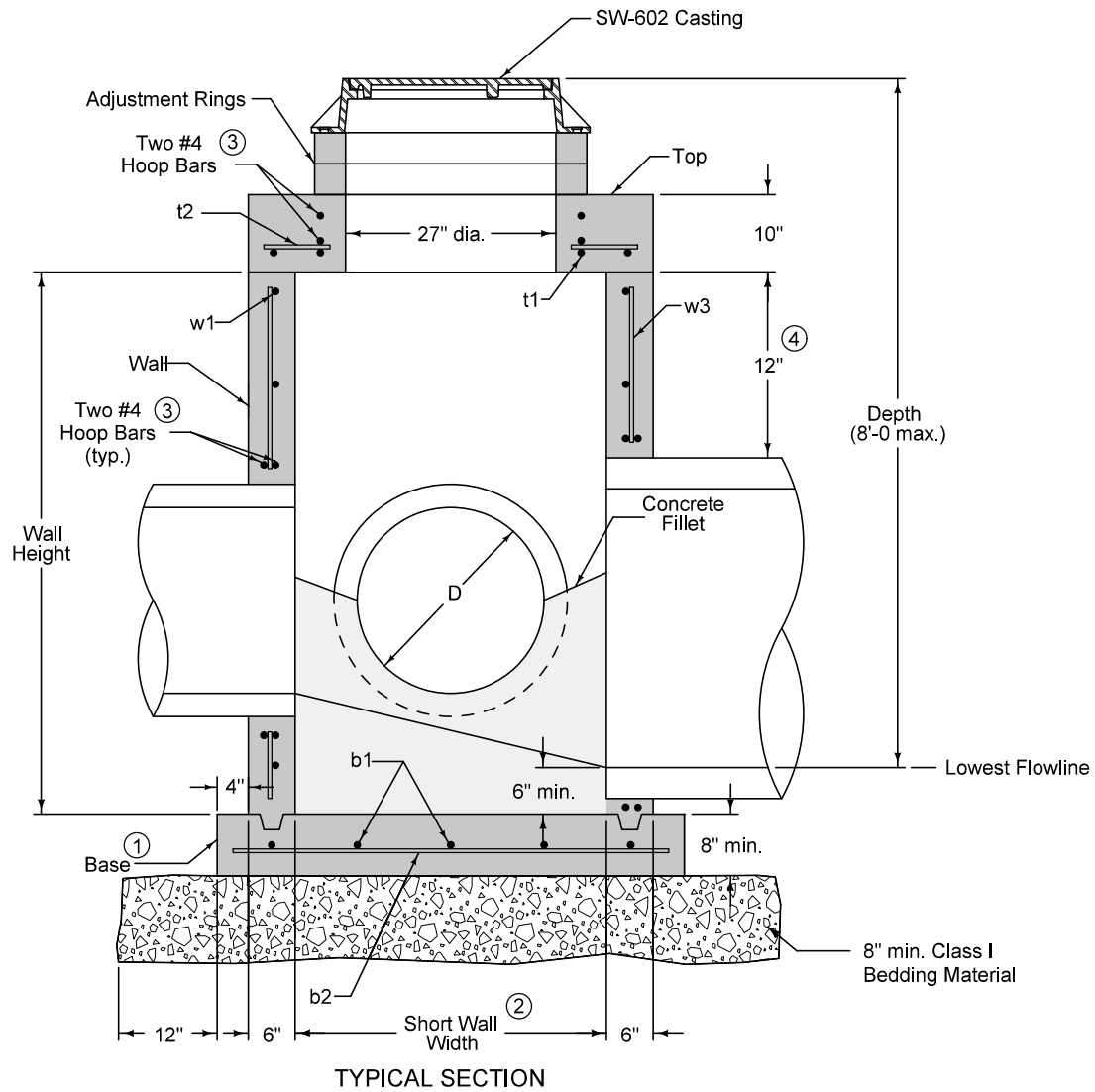

Adjacent walls may have different widths based upon pipe configuration, but structure must be rectangular.

- ① Cast-in-place base shown. If base is precast integral with walls, the footprint of the base is not required to extend beyond the outer edge of the walls.
- ② Wall widths vary with pipe diameter and range from 40 inches minimum to 77 inches maximum. Provide 6 inches of wall width (minimum) each side of pipe opening.
- ③ Provide two #4 hoop bars at top opening and at all pipe openings.
- ④ 12 inch minimum wall height above all pipes.

FIGURE 6010.402 SHEET 1 OF 2

SUDAS	IOWADOT	REVISION
		2 04-21-20
FIGURE 6010.402	STANDARD ROAD PLAN	SW-402
		SHEET 1 of 2
REVISIONS: Added Class I Bedding Material.		
Paul D. Wigand SUDAS DIRECTOR		Shawn Miller DESIGN METHODS ENGINEER
RECTANGULAR STORM SEWER MANHOLE		

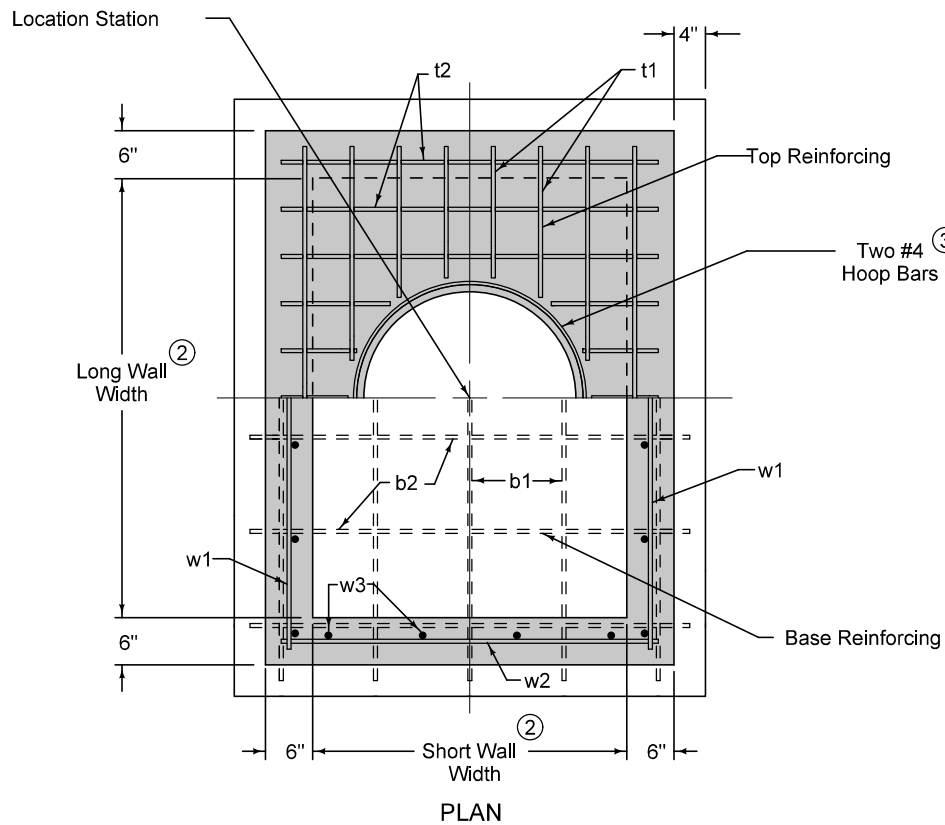

- ② Wall widths vary with pipe diameter and range from 40" minimum to 77" maximum. Provide 6" of wall width (minimum) each side of pipe opening.
- ③ Provide two #4 hoop bars at top opening and at all pipe openings.

REINFORCING BAR LIST					
Mark	Size	Location	Shape	Length	Spacing
t1	See Table	Top	—	Long Wall plus 8"	6"
t2	See Table	Top	—	Short Wall plus 8"	6"
b1	See Table	Base	—	Long Wall plus 14"	12"
b2	See Table	Base	—	Short Wall plus 14"	12"
w1	See Table	Walls	—	Long Wall plus 8"	12"
w2	See Table	Walls	—	Short Wall plus 8"	12"
w3	See Table	Walls	—	Wall Height minus 4"	12"

Diameter of Largest Pipe, D	Minimum Bar Size
48" or 54"	6
33" to 42"	5
30" or smaller	4

FIGURE 6010.402 SHEET 2 OF 2

SUDAS	IOWADOT	REVISION
		2 04-21-20
FIGURE 6010.402	STANDARD ROAD PLAN	SW-402
REVISIONS: Added Class 1 Bedding Material.		SHEET 2 of 2
Paul D. Wigand SUDAS DIRECTOR		Stuart M. Nadeau DESIGN METHODS ENGINEER
RECTANGULAR STORM SEWER MANHOLE		

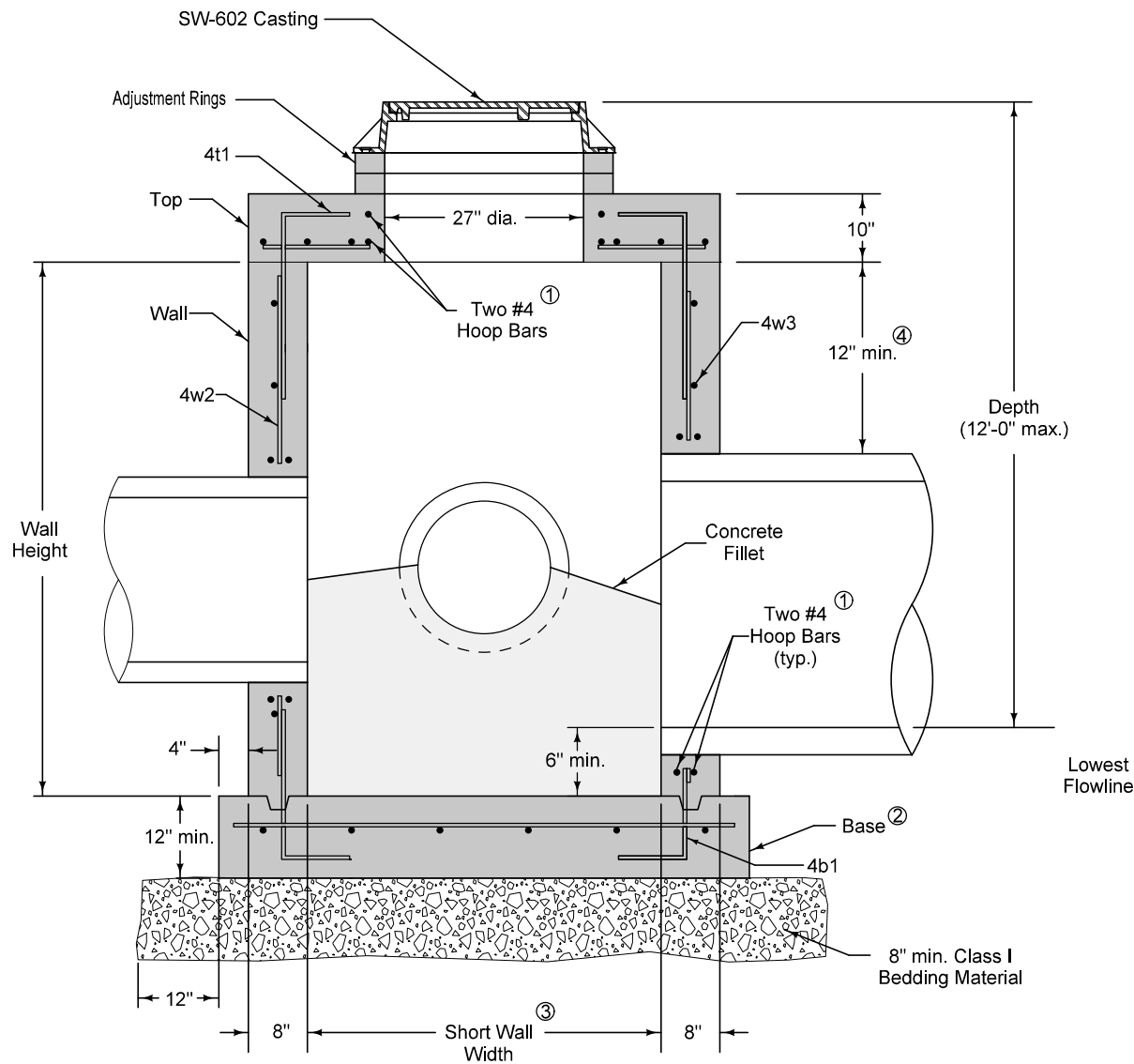

TYPICAL SECTION

Adjacent walls may have different widths based upon pipe configuration, but structure must be rectangular.

- ① Provide two #4 hoop bars at top opening and at all pipe openings.
- ② Cast-in-place base shown. If base is precast integral with walls, the footprint of the base is not required to extend beyond the outer edge of the walls.
- ③ Wall widths vary with pipe diameter and range from 4 feet minimum to 9 feet maximum. Provide 12 inches of wall width (minimum) each side of pipe opening.
- ④ 12 inch minimum wall height above all pipes.

FIGURE 6010.403 SHEET 1 OF 2

SUDAS	IOWADOT	REVISION	
		2	04-21-20
FIGURE 6010.403	STANDARD ROAD PLAN	SW-403 SHEET 1 of 2	
REVISIONS: Added Class I Bedding Material.			
Paul D. Wigand SUDAS DIRECTOR		Shawn Miller DESIGN METHODS ENGINEER	
DEEP WELL RECTANGULAR STORM SEWER MANHOLE			

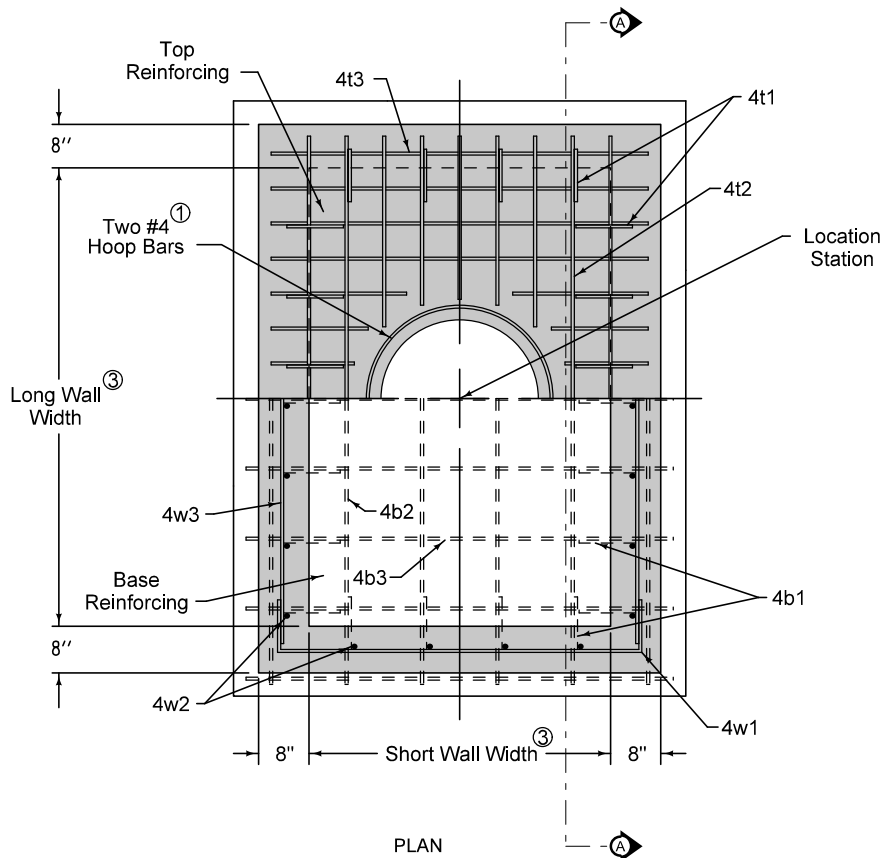

- ① Provide two #4 hoop bars at top opening and at all pipe openings.
- ② Cast-in-place base shown. If base is precast integral with walls, the footprint of the base is not required to extend beyond the outer edge of walls.
- ③ Wall widths vary with pipe diameter and range from 4 feet minimum to 9 feet maximum. Provide 12 inches of wall width (minimum) each side of pipe opening.

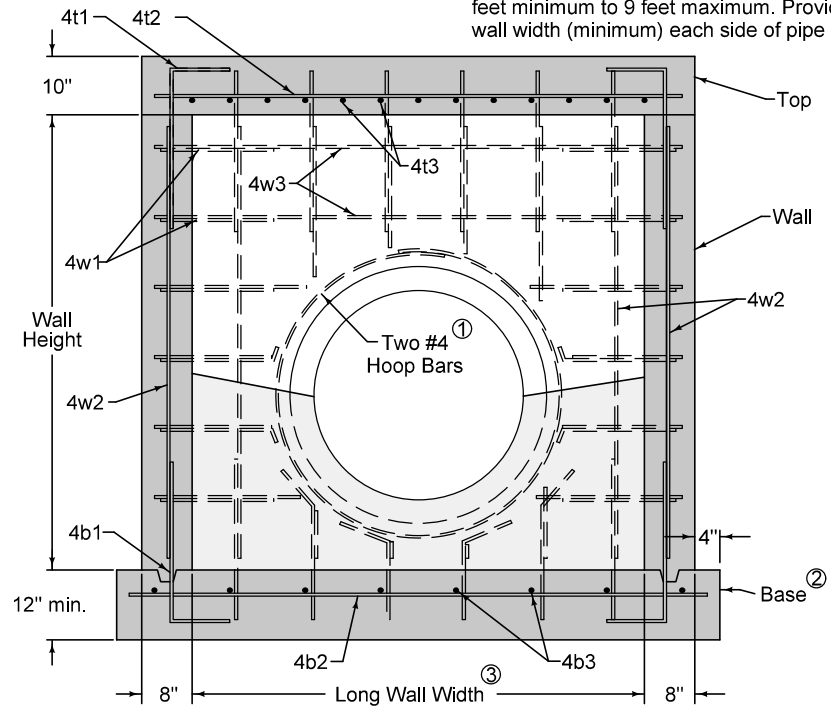

REINFORCING BAR LIST					
Mark	Size	Location	Shape	Length	Spacing
4t1	4	Top	└	36"	12"
4t2	4	Top	—	Long Wall plus 12"	6"
4t3	4	Top	—	Short Wall plus 12"	6"
4b1	4	Base	└	36"	12"
4b2	4	Base	—	Long Wall plus 18"	12"
4b3	4	Base	—	Short Wall plus 18"	12"
4w1	4	Walls	└	Short Wall plus 48"	12"
4w2	4	Walls	—	Wall Height minus 4"	12"
4w3	4	Walls	—	Long Wall plus 12"	12"

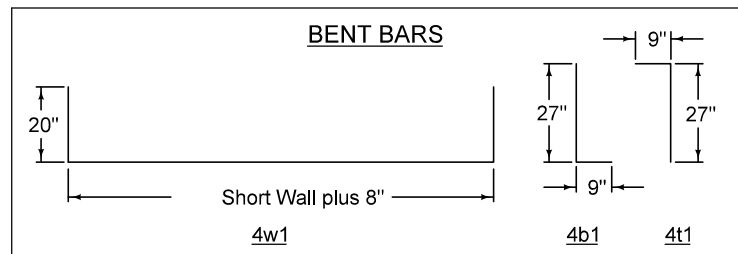

SECTION A-A

SUDAS IOWADOT	REVISION 2 04-21-20
	FIGURE 6010.403 STANDARD ROAD PLAN SW-403 SHEET 2 of 2
REVISIONS: Added Class 1 Bedding Material.	
Paul D. Wigand SUDAS DIRECTOR	
Stuart Miller DESIGN METHODS ENGINEER	
DEEP WELL RECTANGULAR STORM SEWER MANHOLE	

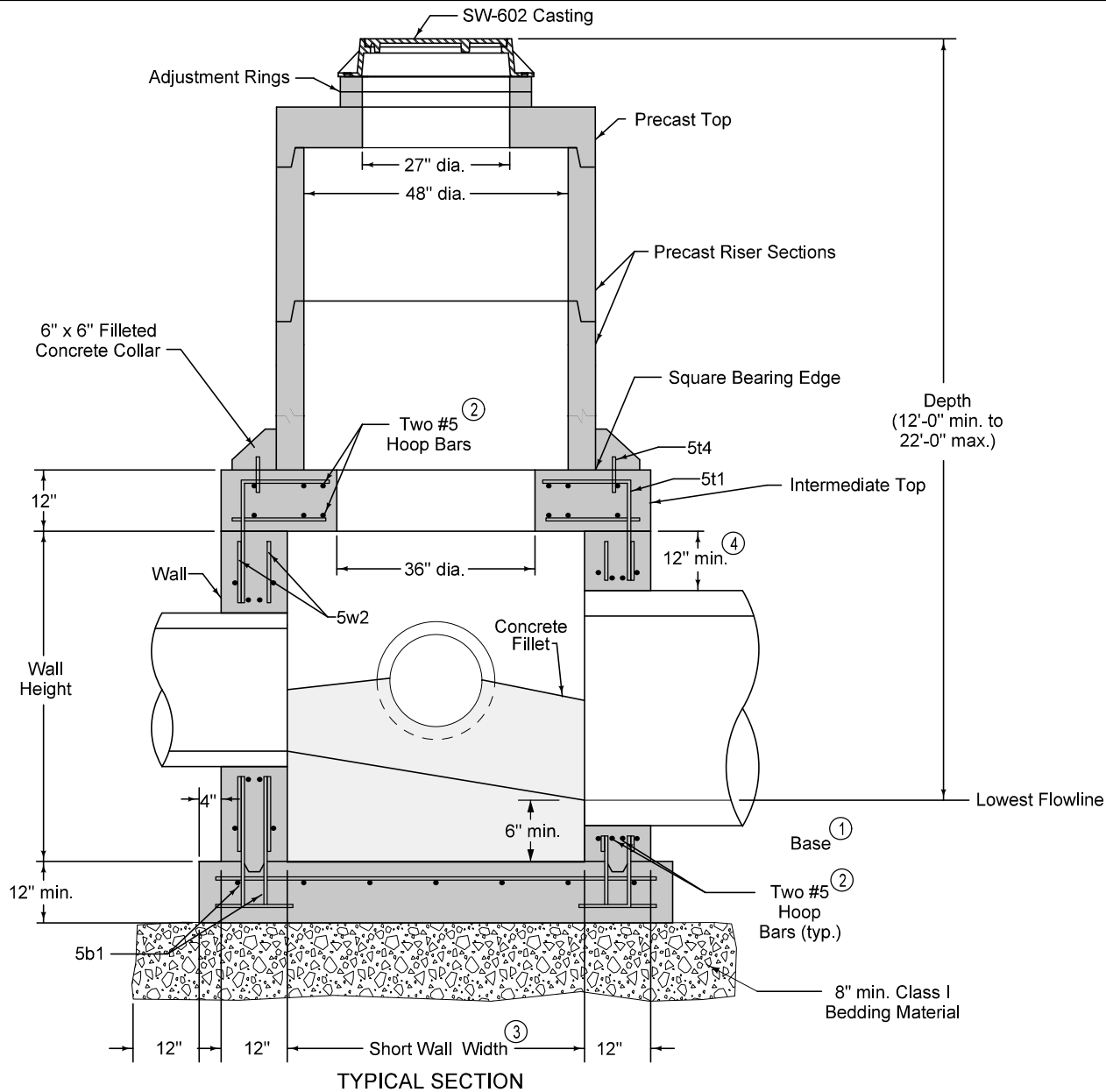

Adjacent walls may have different widths based upon pipe configuration, but structure must be rectangular.

If manhole depth exceeds 20 feet, install steps.

- ① Cast-in-place base shown. If base is precast integral with walls, the footprint of the base is not required to extend beyond the outer edge of the walls.
- ② Provide two #5 hoop bars at intermediate top opening and at all pipe openings.
- ③ Wall widths vary with pipe diameter and range from 4 feet minimum to 12 feet maximum. Provide 12 inches of wall width (minimum) each side of pipe opening.
- ④ 12 inch minimum wall height above all pipes.

FIGURE 6010.404 SHEET 1 OF 2

SUDAS	IOWADOT	REVISION	
		4	04-20-21
FIGURE 6010.404	STANDARD ROAD PLAN	SW-404	
		SHEET 1 of 2	
REVISIONS: Added manhole depth note.			
Paul D. Wigand SUDAS DIRECTOR		Shawn Miller DESIGN METHODS ENGINEER	
RECTANGULAR BASE/ CIRCULAR TOP STORM SEWER MANHOLE			

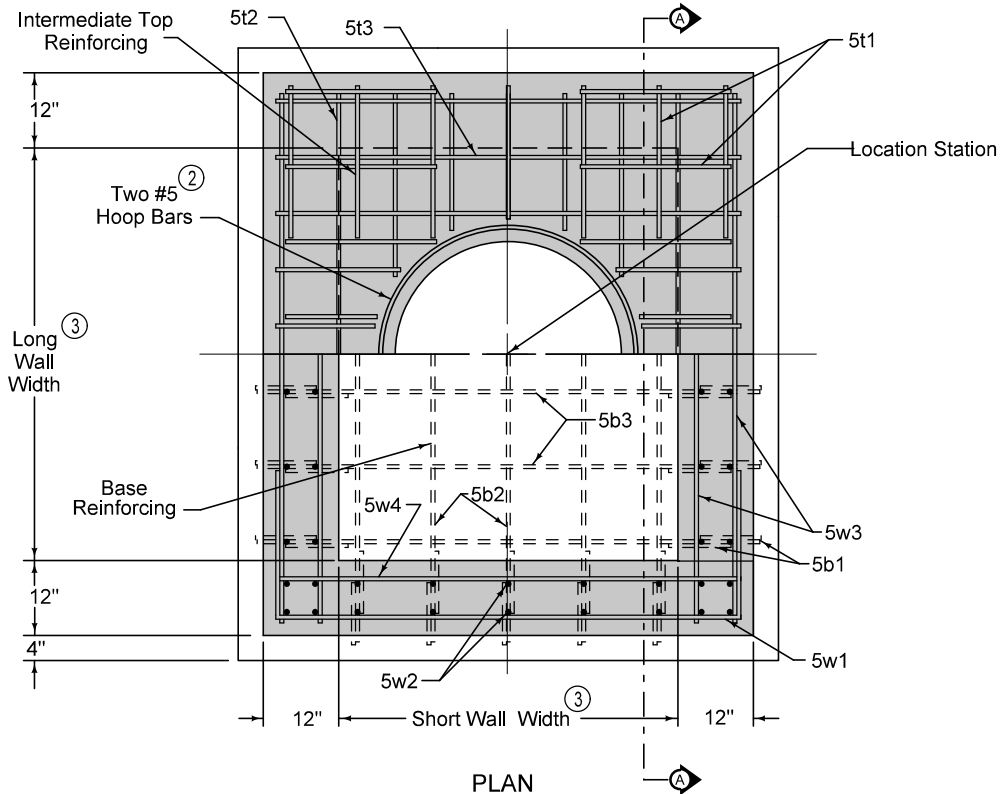

- ② Provide two #5 hoop bars at intermediate top opening and at all pipe openings.
- ③ Wall widths vary with pipe diameter and range from 4 feet minimum to 12 feet maximum. Provide 12 inches of wall width (minimum) each side of pipe opening.

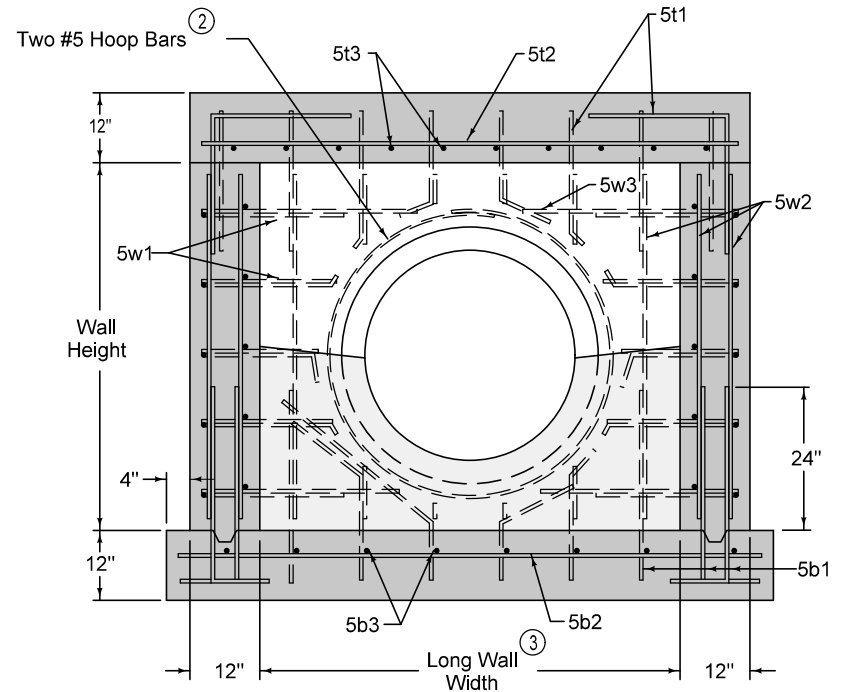

SECTION A-A

REINFORCING BAR LIST					
Mark	Size	Location	Shape	Length	Spacing
5t1	5	Top	L	48"	12"
5t2	5	Top	—	Long Wall plus 20"	9"
5t3	5	Top	—	Short Wall plus 20"	9"
5t4	5	Top	—	8"	12"
5b1	5	Base	L	43"	12"
5b2	5	Base	—	Long Wall plus 26"	12"
5b3	5	Base	—	Short Wall plus 26"	12"
5w1	5	Wall	U	Short Wall plus 68"	12"
5w2	5	Wall	—	Wall Height minus 4"	12"
5w3	5	Wall	—	Long Wall plus 20"	12"
5w4	5	Wall	—	Short Wall plus 20"	12"

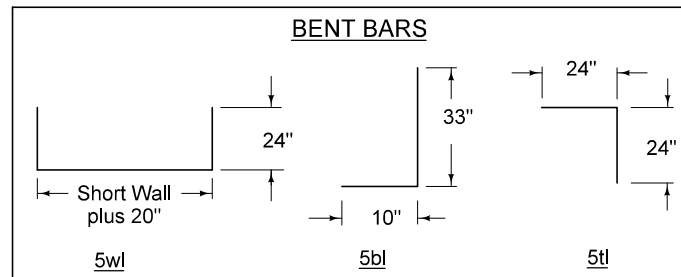

SUDAS IOWADOT	REVISION	4	04-20-21
	FIGURE 6010.404	STANDARD ROAD PLAN	SW-404
REVISIONS: Added manhole depth note.			SHEET 2 of 2

Paul D. Weigand
 SUDAS DIRECTOR / DESIGN METHODS ENGINEER

**RECTANGULAR BASE/
 CIRCULAR TOP
 STORM SEWER MANHOLE**

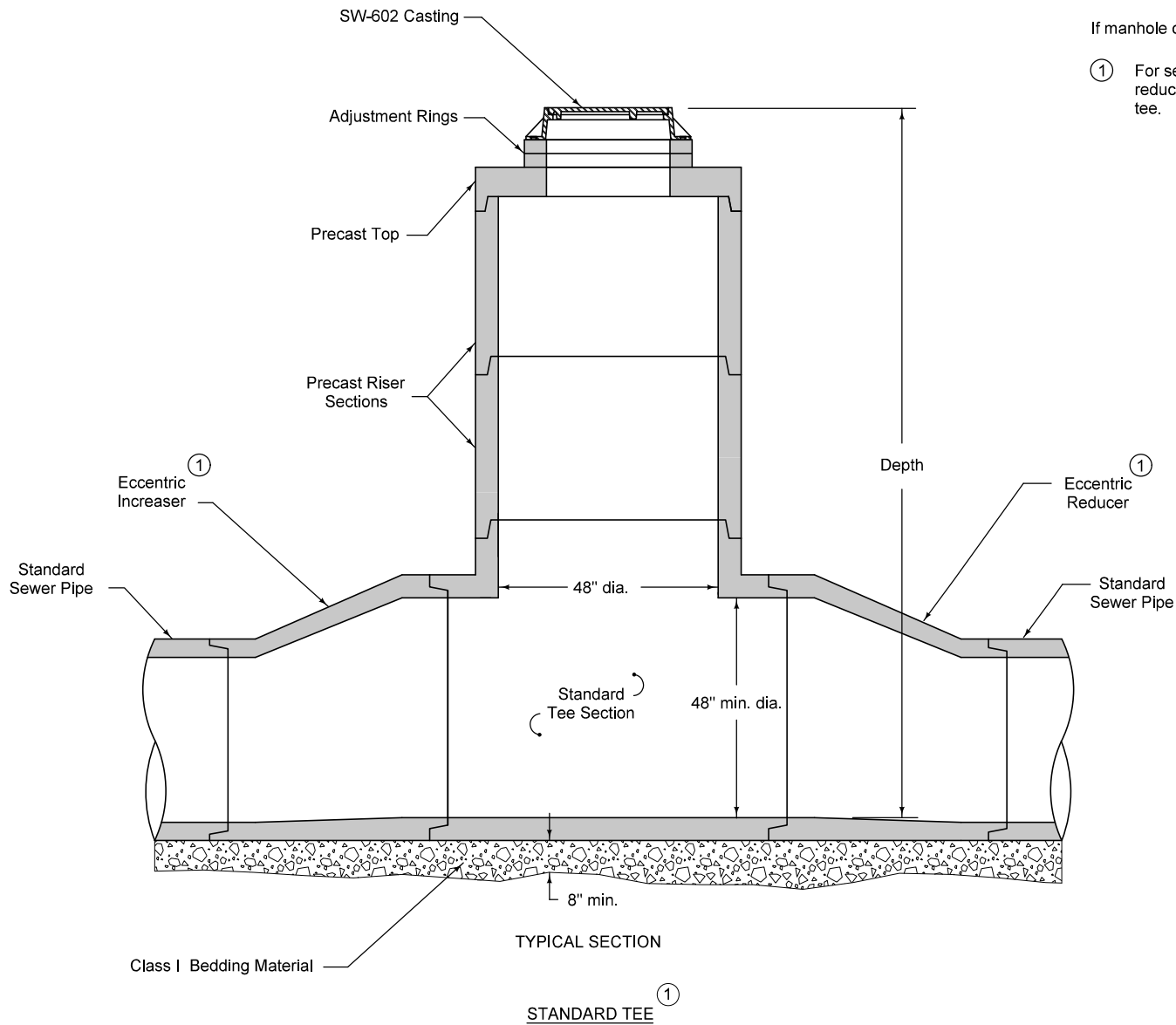

If manhole depth exceeds 20 feet, install steps.

① For sewer pipes less than 48 inch diameter, install eccentric reducers/increasers with a standard tee or utilize a composite tee.

FIGURE 6010.405 SHEET 1 OF 2

SUDAS	IOWADOT	REVISION
		4 04-20-21
FIGURE 6010.405	STANDARD ROAD PLAN	SW-405
		SHEET 1 of 2
REVISIONS: Added manhole depth note.		
Paul D. Wigand SUDAS DIRECTOR		Stuart Miller DESIGN METHODS ENGINEER
TEE-SECTION STORM SEWER MANHOLE		

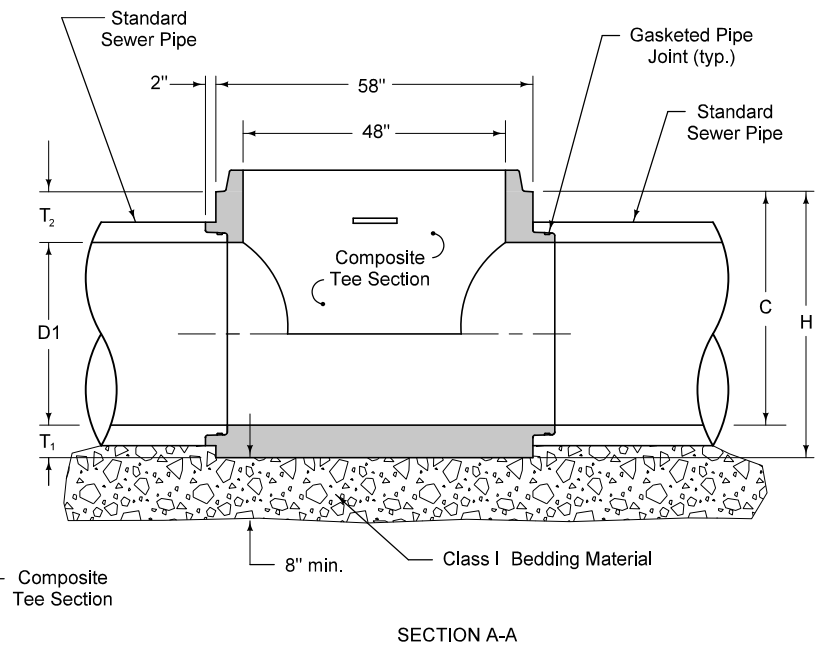
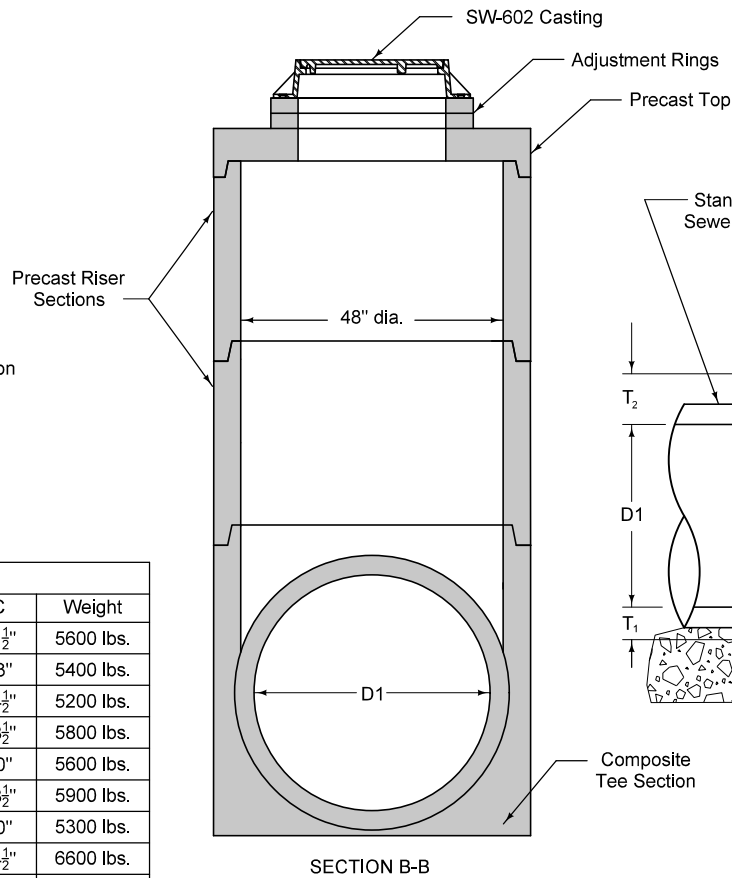
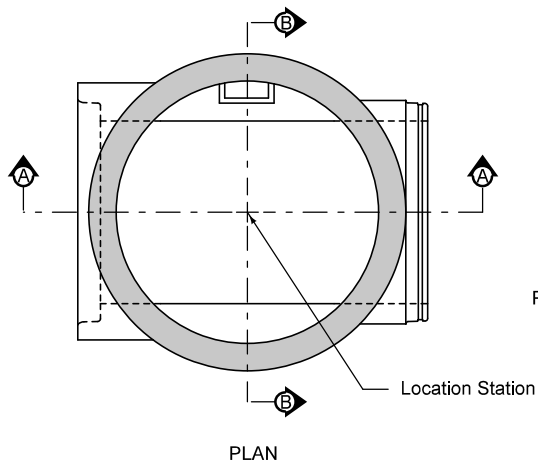

COMPOSITE TEE DIMENSIONS						
Size	D1	H	T ₁	T ₂	C	Weight
48" on 12"	12"	50"	8½"	29½"	41½"	5600 lbs.
48" on 15"	15"	50"	7"	28"	43"	5400 lbs.
48" on 18"	18"	50"	5½"	26½"	44½"	5200 lbs.
48" on 21"	21"	48"	9½"	17½"	38½"	5800 lbs.
48" on 24"	24"	48"	8"	16"	40"	5600 lbs.
48" on 27"	27"	48"	9½"	11½"	38½"	5900 lbs.
48" on 30"	30"	48"	8"	10"	40"	5300 lbs.
48" on 33"	33"	54"	9½"	11½"	44½"	6600 lbs.
48" on 36"	36"	54"	8"	10"	46"	6100 lbs.

SECTION B-B

COMPOSITE TEE

Alternate to standard tee with eccentric reducer (for pipes 36" and smaller).

FIGURE 6010.405 SHEET 2 OF 2

SUDAS IOWADOT	REVISION 4 04-20-21
	SW-405 SHEET 2 of 2
FIGURE 6010.405 STANDARD ROAD PLAN	REVISIONS: Added manhole depth note.
<i>Paul D. Wigand</i> SUDAS DIRECTOR	<i>Stuart Nade</i> DESIGN METHODS ENGINEER
TEE-SECTION STORM SEWER MANHOLE	

Adjacent walls may have different widths based upon pipe configuration, but structure must be rectangular.

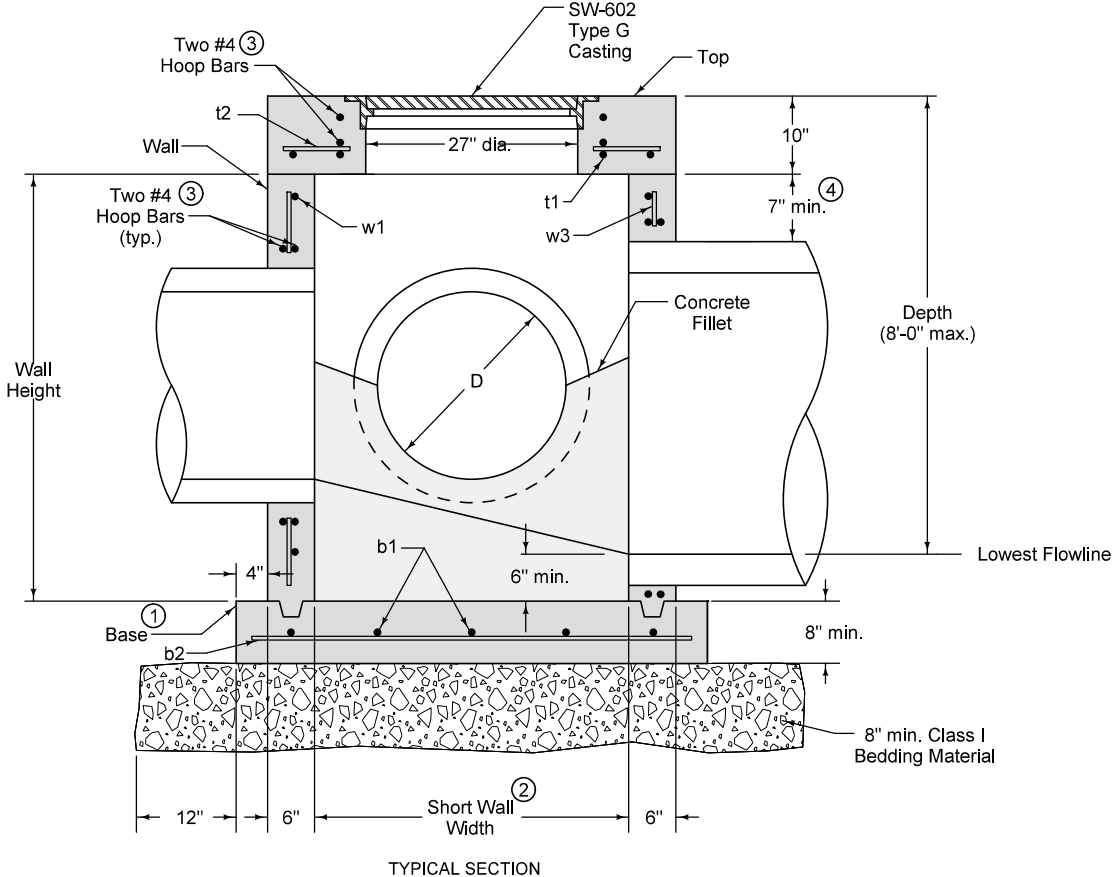

- ① Cast-in-place base shown. If base is precast integral with walls, the footprint of the base is not required to extend beyond the outer edge of the walls.
- ② Wall widths vary with pipe diameter and range from 40 inches minimum to 77 inches maximum. Provide 6 inches of wall width (minimum) each side of pipe opening.
- ③ Provide two #4 hoop bars at top opening and at all pipe openings.
- ④ 7 inch minimum wall height above all pipes.

FIGURE 6010.406 SHEET 1 OF 2

SUDAS	IOWADOT	REVISION	
		2	04-21-20
FIGURE 6010.406	STANDARD ROAD PLAN	SW-406 SHEET 1 of 2	
REVISIONS: Added Class I Bedding Material.			
Paul D. Wigand SUDAS DIRECTOR		Stuart Miller DESIGN METHODS ENGINEER	
SHALLOW RECTANGULAR STORM SEWER MANHOLE			

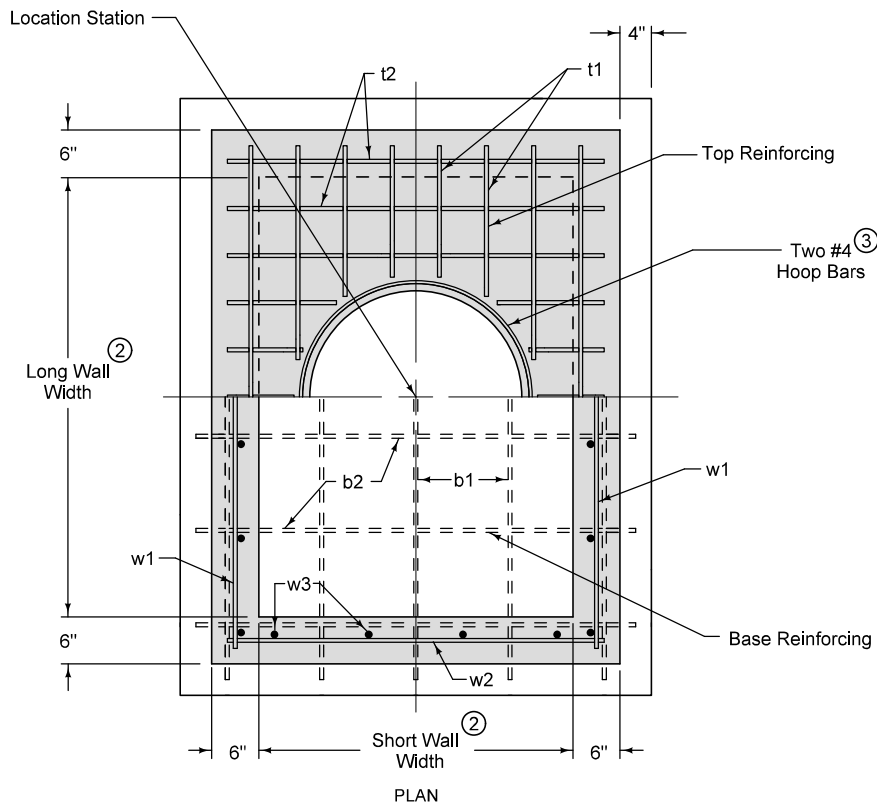

- ② Wall widths vary with pipe diameter and range from 40 inches minimum to 77 inches maximum. Provide 6 inches of wall width (minimum) each side of pipe opening.
- ③ Provide two #4 hoop bars at top opening and at all pipe openings.

REINFORCING BAR LIST					
Mark	Size	Location	Shape	Length	Spacing
t1	See Table	Top	—	Long Wall plus 8"	6"
t2	See Table	Top	—	Short Wall plus 8"	6"
b1	See Table	Base	—	Long Wall plus 14"	12"
b2	See Table	Base	—	Short Wall plus 14"	12"
w1	See Table	Walls	—	Long Wall plus 8"	12" ^f
w2	See Table	Walls	—	Short Wall plus 8"	12"
w3	See Table	Walls	—	Wall Height minus 4"	12"

^fPlace a minimum of one w1 bar above each pipe opening

Diameter of Largest Pipe, D	Minimum Bar Size
48" or 54"	6
33" to 42"	5
30" or smaller	4

FIGURE 6010.406 SHEET 2 OF 2

SUDAS IOWADOT	REVISION 2 04-21-20
	FIGURE 6010.406 STANDARD ROAD PLAN SHEET 2 of 2
REVISIONS: Added Class 1 Bedding Material.	
Paul D. Wigand SUDAS DIRECTOR	
Stuart M. Nelson DESIGN METHODS ENGINEER	
SHALLOW RECTANGULAR STORM SEWER MANHOLE	

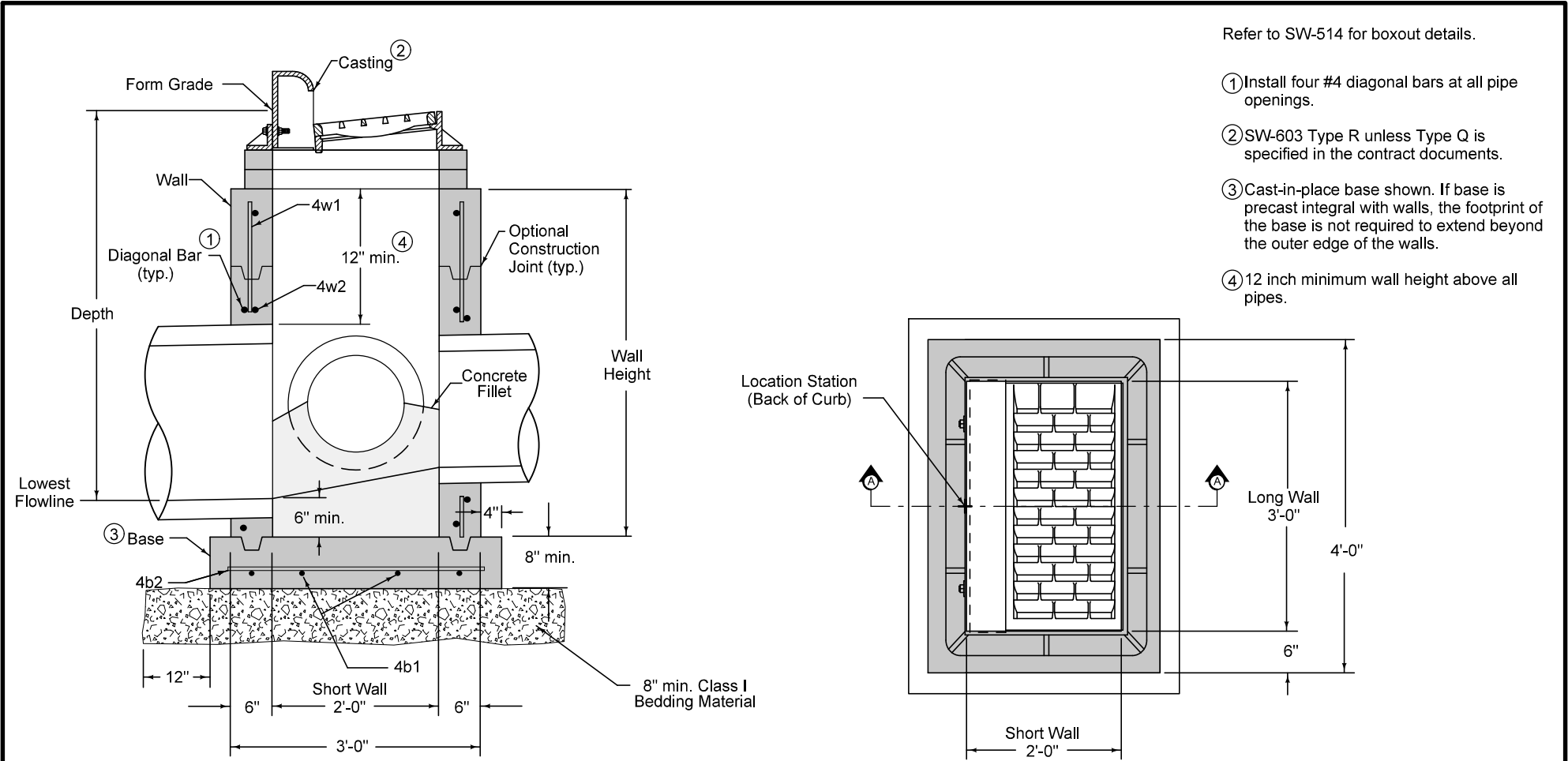

Refer to SW-514 for boxout details.

- ① Install four #4 diagonal bars at all pipe openings.
- ② SW-603 Type R unless Type Q is specified in the contract documents.
- ③ Cast-in-place base shown. If base is precast integral with walls, the footprint of the base is not required to extend beyond the outer edge of the walls.
- ④ 12 inch minimum wall height above all pipes.

SECTION A-A

PLAN

REINFORCING BAR LIST

Mark	Size	Location	Shape	Length	Count	Spacing
4w1	4	Walls	—	Wall Height minus 4"	14	12"
4w2	4	Long Walls	—	3'-8"	Varies	12"
4w3	4	Short Walls	—	2'-8"	Varies	12"
4b1	4	Base	—	4'-2"	4	10"
4b2	4	Base	—	3'-2"	5	10"

Pipe Location	MAXIMUM PIPE DIAMETERS	
	Precast Structure	Cast-in-place Structure
Short Wall	15"	18"
Long Wall	24"	30"

SUDAS IOWADOT	REVISION 3 04-21-20
	SW-501 SHEET 1 of 1
FIGURE 6010.501 STANDARD ROAD PLAN	REVISIONS: Added Class I Bedding Material.
Paul D. Wigand SUDAS DIRECTOR	Stuart M. Nade DESIGN METHODS ENGINEER
SINGLE GRATE INTAKE	

FIGURE 6010.501 SHEET 1 OF 1

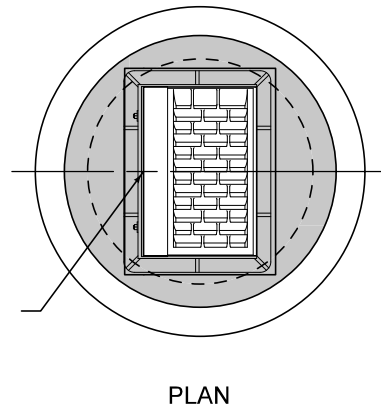
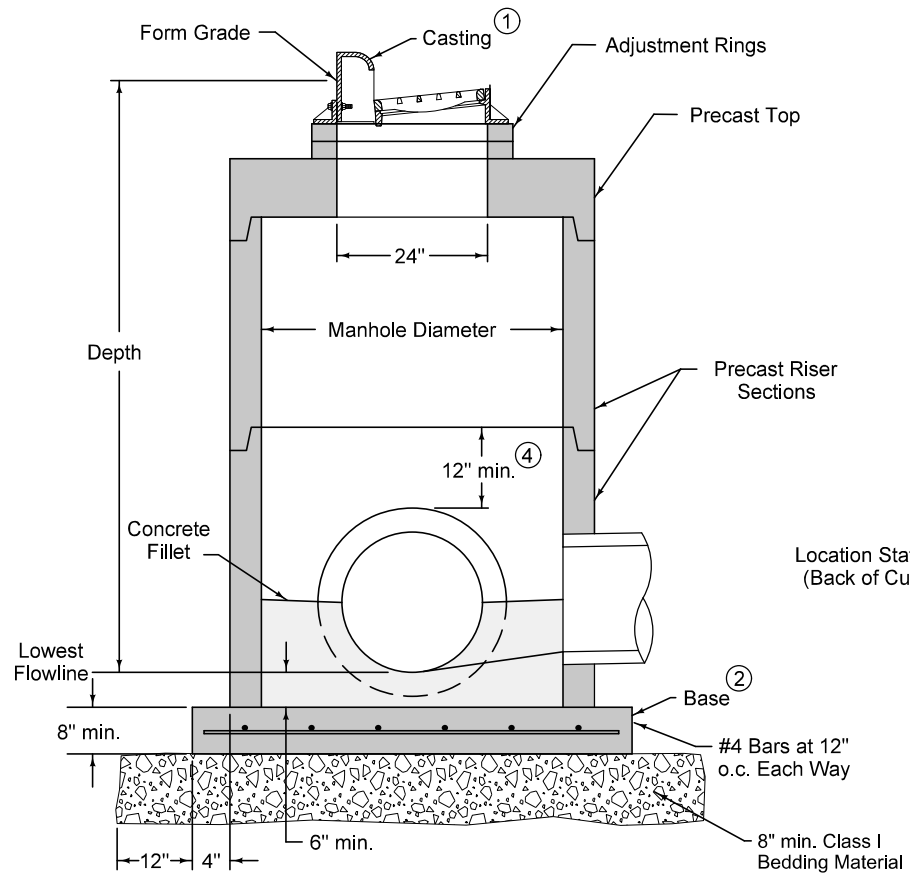

TYPICAL SECTION

Refer to SW-514 for boxout details.

- ① SW-603 Type R unless Type Q is specified in the contract documents.
- ② Cast-in-place base shown. Base may be square. If base is precast integral with walls, the footprint of the base is not required to extend beyond the outer edge of the walls.
- ③ For additional configurations, maintain a minimum of 12 inches of concrete between vertical edges of pipe openings.
- ④ 12 inch minimum riser height above all pipes.

Manhole Diameter (inches)	Maximum Pipe Diameter (inches) for 2 Pipes ③	
	at 180° Separation	at 90° Separation
48	24	18
60	36	24
72	42	30
84	48	36
96	60	42

FIGURE 6010.502 SHEET 10F

		REVISION
		1 04-21-20
FIGURE 6010.502	STANDARD ROAD PLAN	SW-502
		SHEET 1 of 1
REVISIONS: Added Class I Bedding Material.		
<i>Paul D. Wigand</i> SUDAS DIRECTOR		<i>Stuart Nade</i> DESIGN METHODS ENGINEER
CIRCULAR SINGLE GRATE INTAKE		

Refer to SW-514 for boxout details.

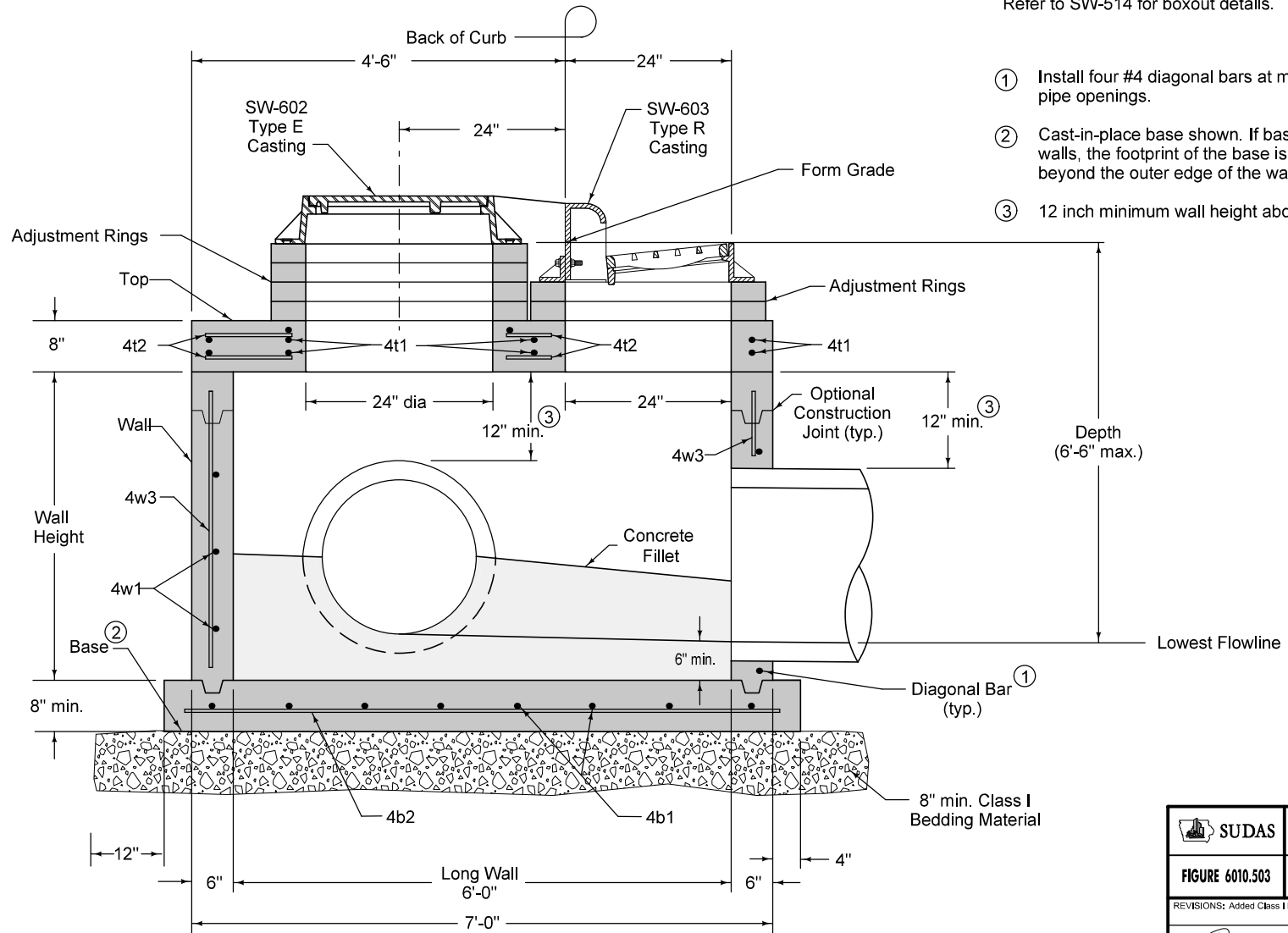

- ① Install four #4 diagonal bars at manhole opening and at all pipe openings.
- ② Cast-in-place base shown. If base is precast integral with walls, the footprint of the base is not required to extend beyond the outer edge of the walls.
- ③ 12 inch minimum wall height above all pipes.

TYPICAL SECTION

FIGURE 6010.503 SHEET 1 OF 2

SUDAS	IOWADOT	REVISION	
		3	04-21-20
FIGURE 6010.503	STANDARD ROAD PLAN	SW-503	
REVISIONS: Added Class I Bedding Material.		SHEET 1 of 2	
Paul D. Wiegand SUDAS DIRECTOR		Stuart Miller DESIGN METHODS ENGINEER	
SINGLE GRATE INTAKE WITH MANHOLE			

① Install four #4 diagonal bars at manhole opening and at all pipe openings.

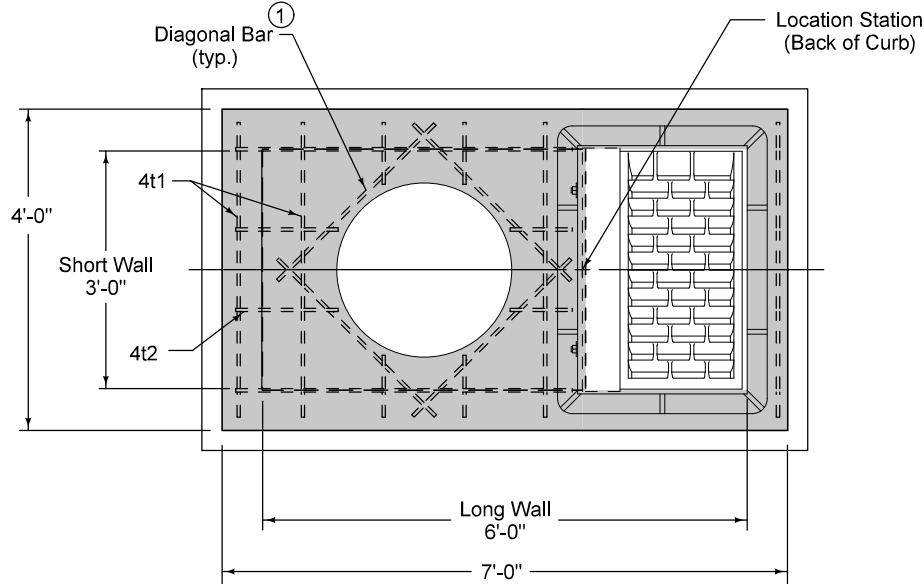

PLAN

REINFORCING BAR LIST						
Mark	Size	Location	Shape	Count	Length	Spacing
4t1	4	Top	—	12	3'-8"	12"
4t2	4	Top	—	8	4'-2"	12"
4b1	4	Base	—	7	4'-2"	13"
4b2	4	Base	—	5	7'-2"	10"
4w1	4	Short Walls	—	Varies	3'-8"	12"
4w2	4	Long Walls	—	Varies	6'-8"	12"
4w3	4	Walls	—	18	Wall Height minus 4"	13"

MAXIMUM PIPE DIAMETERS		
Pipe Location	Precast Structure	Cast-in-place Structure
Short Wall	24"	30"
Long Wall	30"	36"

FIGURE 6010.503 SHEET 2 OF 2

SUDAS	IOWADOT	REVISION
		3 04-21-20
FIGURE 6010.503	STANDARD ROAD PLAN	SW-503
REVISIONS: Added Class 1 Bedding Material.		SHEET 2 of 2
Paul D. Wigand SUDAS DIRECTOR		Stuart M. Nelson DESIGN METHODS ENGINEER
SINGLE GRATE INTAKE WITH MANHOLE		

Refer to SW-514 for boxout details.

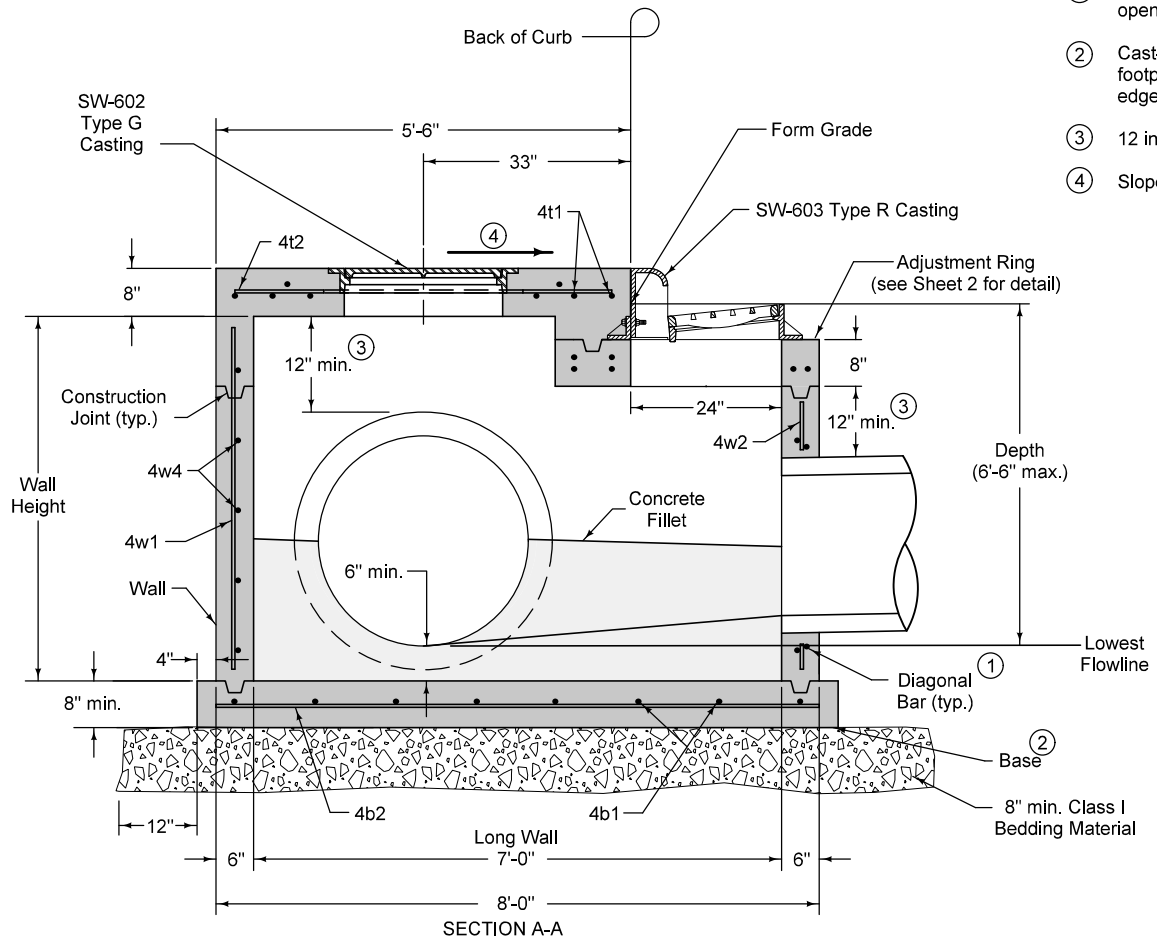

- ① Install four #4 diagonal bars at manhole opening and at all pipe openings.
- ② Cast-in-place base shown. If base is precast integral with walls, the footprint of the base is not required to extend beyond the outer edge of the walls.
- ③ 12 inch minimum wall height above all pipes.
- ④ Slope of 1.5% or as specified in the contract documents.

FIGURE 6010.504 SHEET 1 OF 2

SUDAS IOWADOT	REVISION	
	4	04-21-20
FIGURE 6010.504	STANDARD ROAD PLAN	SW-504
REVISIONS: Added Class I Bedding Material.		SHEET 1 of 2
Paul D. Wigand SUDAS DIRECTOR		Stuart Miller DESIGN METHODS ENGINEER
SINGLE GRATE INTAKE WITH FLUSH-TOP MANHOLE		

① Install four #4 diagonal bars at manhole opening and at all pipe openings.

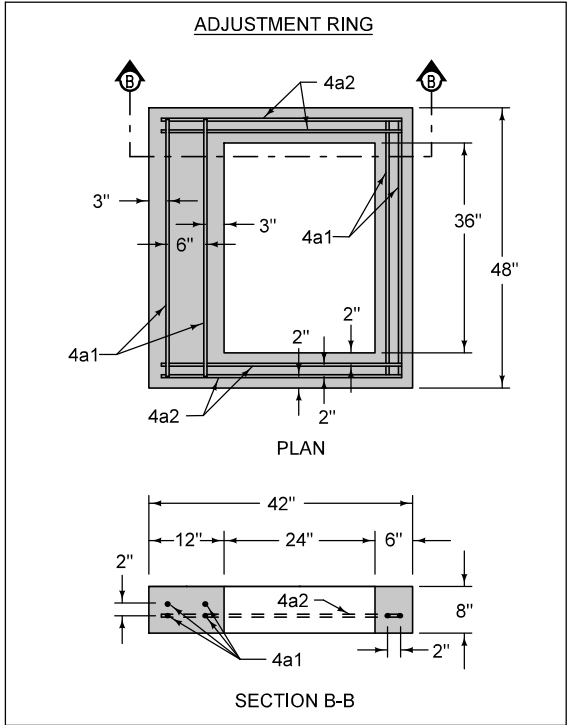
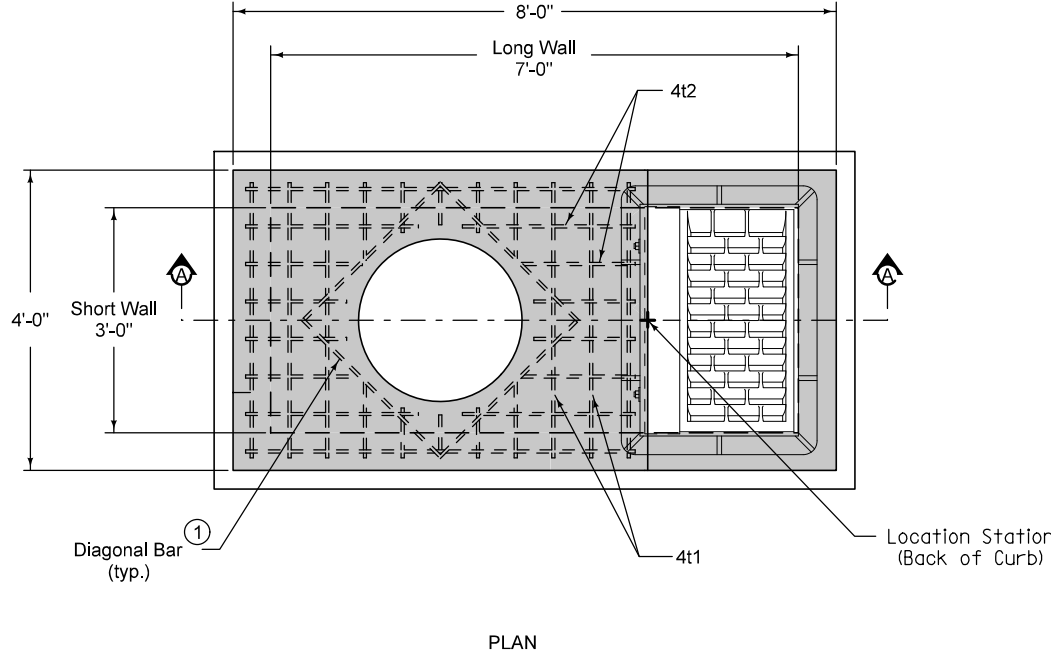

REINFORCING BAR LIST						
Mark	Size	Location	Shape	Count	Length	Spacing
4t1	4	Top	—	11	3'-8"	6"
4t2	4	Top	—	8	5'-2"	6"
4b1	4	Base	—	8	4'-2"	13"
4b2	4	Base	—	5	8'-2"	10"
4a1	4	Adj. Ring	—	6	3'-8"	See Adj. Ring Plan
4a2	4	Adj. Ring	—	4	3'-2"	See Adj. Ring Plan
4w1	4	Walls	—	13	Wall Height minus 4"	12"
4w2	4	Walls	—	11	Wall Height minus 16"	12"
4w3	4	Long Walls	—	Varies	7'-8"	12"
4w4	4	Short Walls	—	Varies	3'-8"	12"

MAXIMUM PIPE DIAMETERS		
Pipe Location	Precast Structure	Cast-in-place Structure
Short Wall	18"	24"
Long Wall	30"	36"

SUDAS IOWADOT	REVISION 4 04-21-20
	FIGURE 6010.504 STANDARD ROAD PLAN SW-504 SHEET 2 of 2
REVISIONS: Added Class 1 Bedding Material.	
Paul D. Wigand SUDAS DIRECTOR	
Stuart Miller DESIGN METHODS ENGINEER	
SINGLE GRATE INTAKE WITH FLUSH-TOP MANHOLE	

FIGURE 6010.504 SHEET 2 OF 2

Refer to SW-514 for boxout details.

- ① Install four #4 diagonal bars at all pipe openings.
- ② Cast-in-place base shown. If base is precast integral with walls, the footprint of the base is not required to extend beyond the outer edge of the walls.
- ③ 12 inch minimum wall height above all pipes.

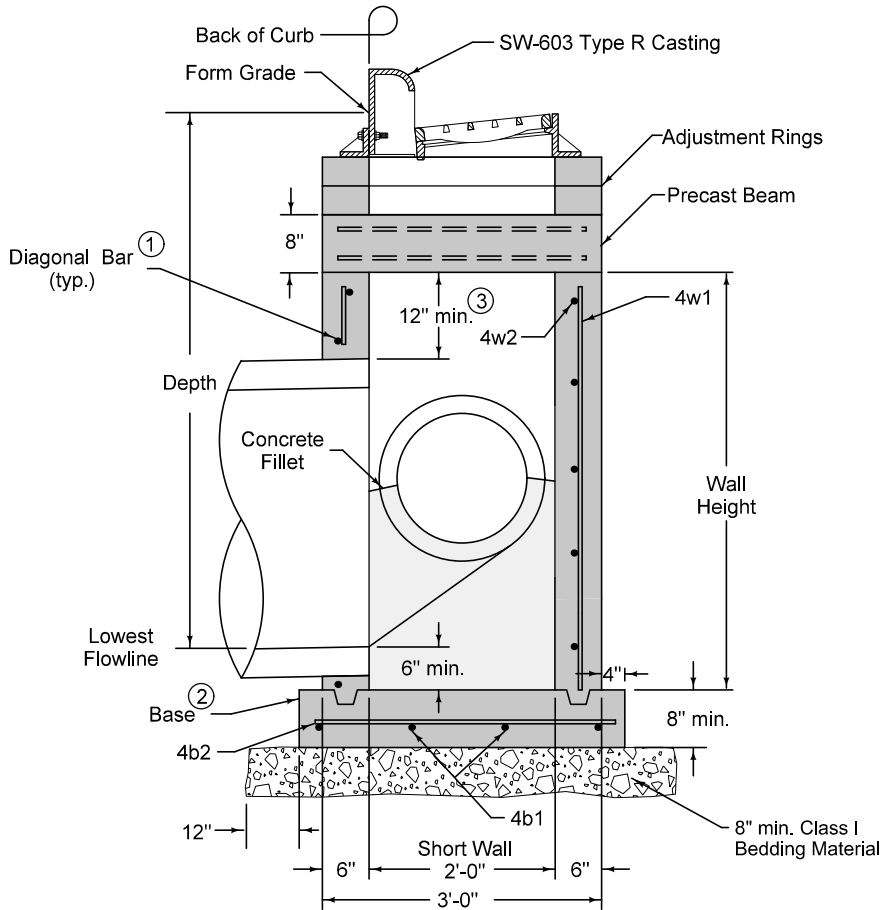

SECTION A-A

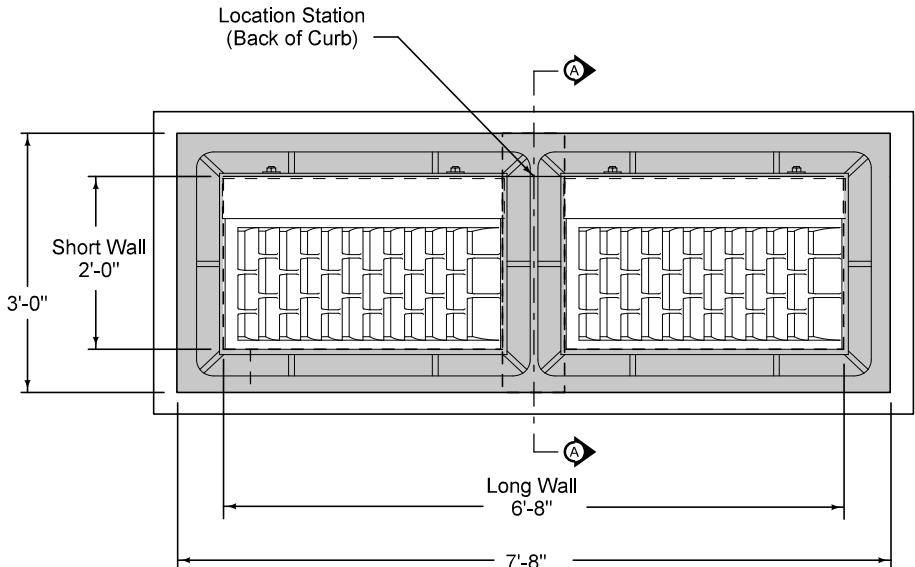

PLAN

FIGURE 6010.505 SHEET 1 OF 2

SUDAS	IOWADOT	REVISION
		3 04-21-20
FIGURE 6010.505	STANDARD ROAD PLAN	SW-505
REVISIONS: Added Class I Bedding Material.		SHEET 1 of 2
Paul D. Wiegand SUDAS DIRECTOR		Stuart Miller DESIGN METHODS ENGINEER
DOUBLE GRATE INTAKE		

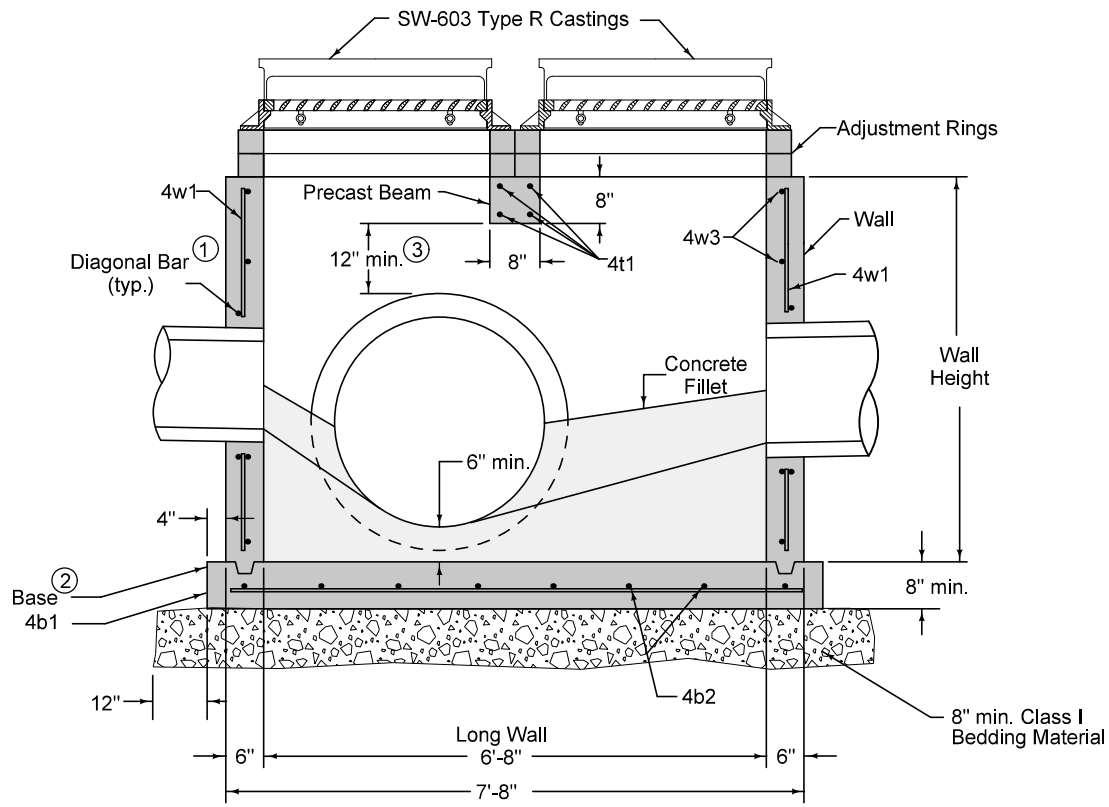

- ① Install four #4 diagonal bars at all pipe openings.
- ② Cast-in-place base shown. If base is precast integral with walls, the footprint of the base is not required to extend beyond the outer edge of the walls.
- ③ 12 inch minimum wall height above all pipes.

TYPICAL SECTION

REINFORCING BAR LIST

Mark	Size	Location	Shape	Count	Length	Spacing
4t1	4	Beam	—	4	2'-8"	4"
4b1	4	Base	—	4	7'-10"	10"
4b2	4	Base	—	8	3'-2"	12"
4w1	4	Walls	—	20	Wall Height minus 4"	12"
4w2	4	Long Walls	—	Varies	7'-4"	12"
4w3	4	Short Walls	—	Varies	2'-8"	12"

MAXIMUM PIPE DIAMETERS		
Pipe Location	Precast Structure	Cast-in-place Structure
Short Wall	15"	18"
Long Wall	60"	66"

FIGURE 6010.505 SHEET 2 OF 2

SUDAS IOWADOT	REVISION	3	04-21-20
	FIGURE 6010.505	STANDARD ROAD PLAN	SW-505
REVISIONS: Added Class I Bedding Material.		SHEET 2 of 2	
Paul D. Wigand <small>SUDAS DIRECTOR</small>		Scott Miller <small>DESIGN METHODS ENGINEER</small>	
DOUBLE GRATE INTAKE			

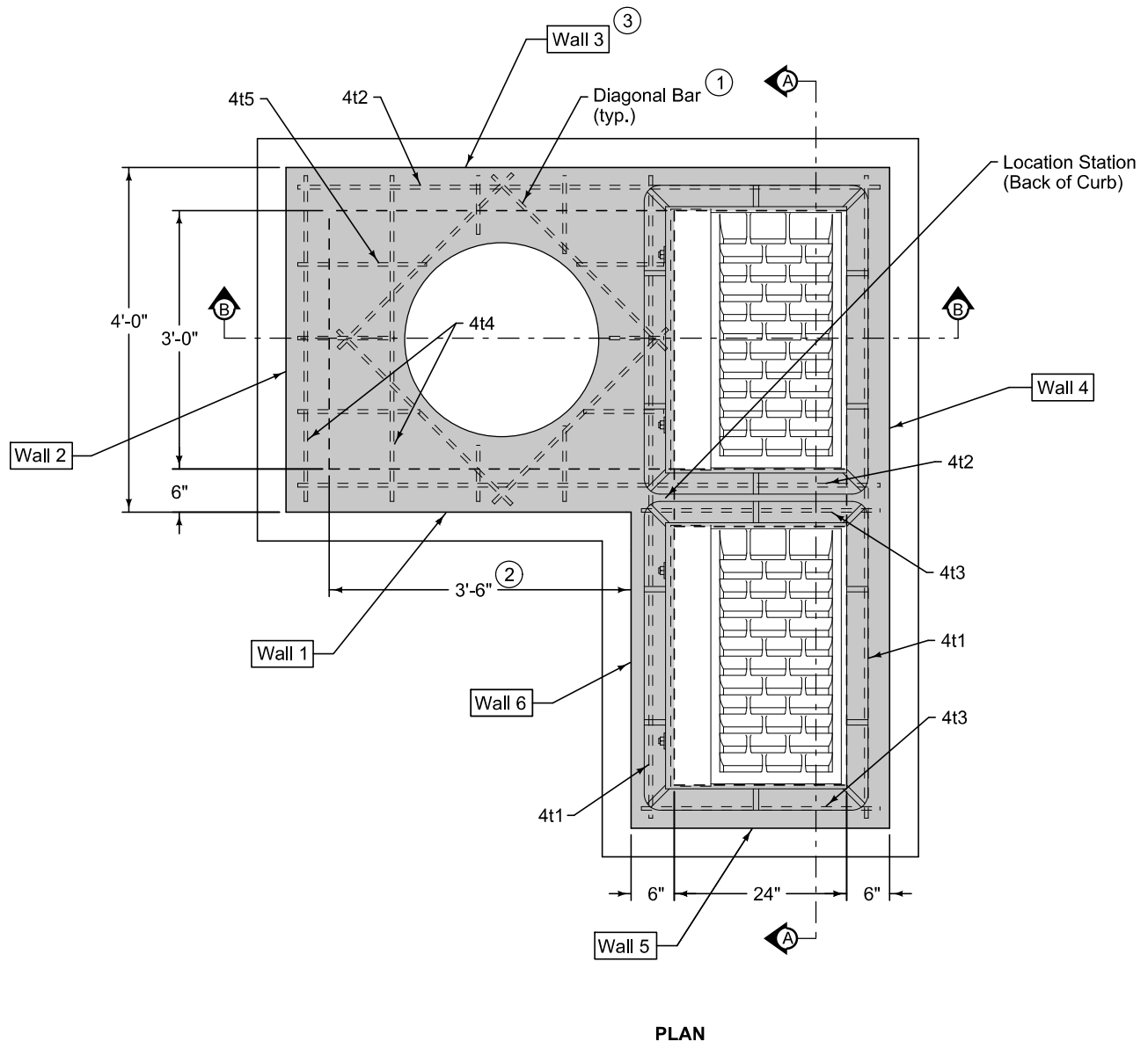

Maximum pipe diameters are set based on maximum structure depth of 6 feet-6 inches and the objective of placement of the centerline of the pipe on the centerline of the manhole opening for maintenance purposes.

Refer to SW-514 for boxout details.

- ① Install four #4 diagonal bars at manhole opening and at all pipe openings.
- ② If Wall 1 is widened to 4 feet, the maximum pipe diameter can be increased to 36 inches.
- ③ If Wall 1 is widened to 4 feet, the maximum pipe diameter in Wall 3 can be increased to 42 inches.

MAXIMUM PIPE DIAMETERS	
Wall	Max. Dia.
1	30" ②
2	24"
3	36" ③
4	42"

SUDAS IOWADOT	REVISION
	4 04-21-20
FIGURE 6010.506	STANDARD ROAD PLAN
Paul D. Wigand SUDAS DIRECTOR	
Scott Miller DESIGN METHODS ENGINEER	
DOUBLE GRATE INTAKE WITH MANHOLE	

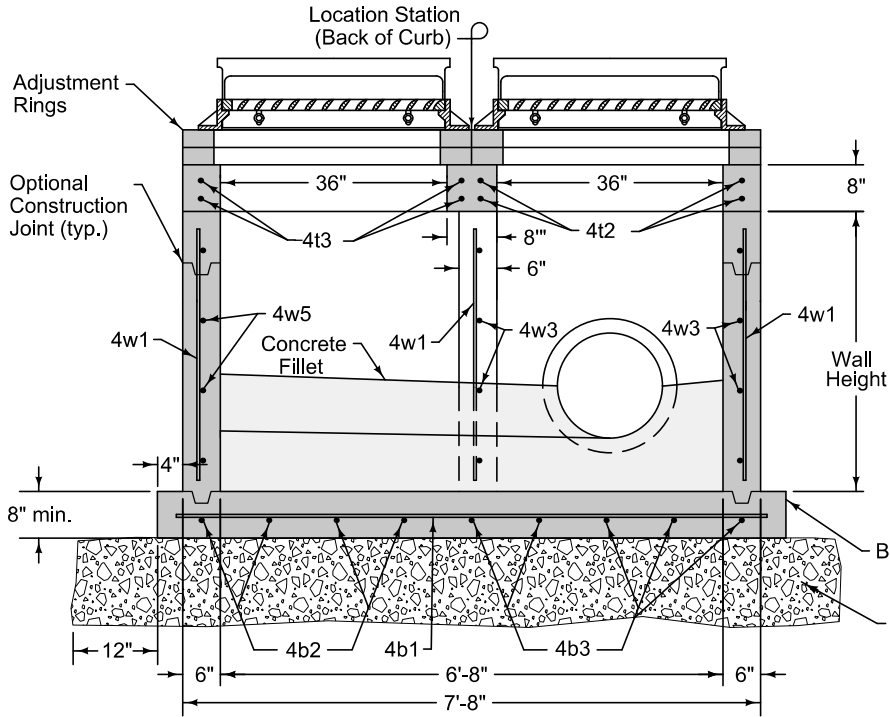

SECTION A-A

REINFORCING BAR LIST						
Mark	Size	Location	Shape	Count	Length	Spacing
4t1	4	Top	—	4	7'-4"	See Detail
4t2	4	Top	—	4	6'-8"	See Detail
4t3	4	Top	—	4	2'-8"	See Detail
4t4	4	Top	—	8	3'-8"	12"
4t5	4	Top	—	6	4'-2"	12"
4b1	4	Base	—	4	7'-10"	12"
4b2	4	Base	—	4	3'-2"	12"
4b3	4	Base	—	5	7'-2"	12"
4b4	4	Base	—	4	4'-2"	12"
4w1	4	Walls	—	29	Wall Height minus 4"	12"
4w2	4	Wall 2	—	Varies	3'-8"	12"
4w3	4	Walls 1 and 3	—	Varies	6'-8"	12"
4w4	4	Wall 4	—	Varies	7'-4"	12"
4w5	4	Wall 5	—	Varies	2'-8"	12"
4w6	4	Wall 6	—	Varies	3'-10"	12"

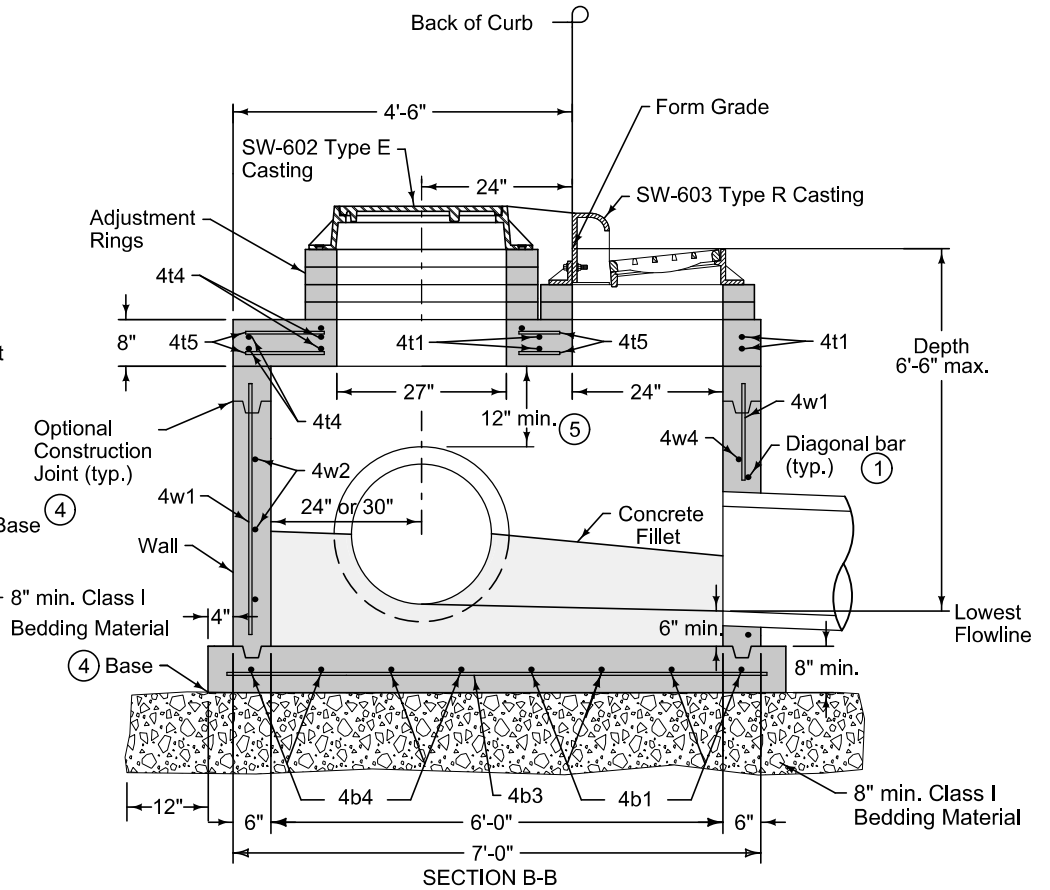

SECTION B-B

- ① Install four #4 diagonal bars at manhole opening and at all pipe openings.
- ④ Cast-in-place base shown. If base is precast integral with walls, the footprint of base is not required to extend beyond the outer edge of the walls.
- ⑤ 12 inch minimum wall height above all pipes.

FIGURE 6010.506 SHEET 2 OF 2

		REVISION
		4 04-21-20
FIGURE 6010.506	STANDARD ROAD PLAN	SW-506
REVISIONS: Added Class I Bedding Material.		SHEET 2 of 2
SUDAS DIRECTOR		DESIGN METHODS ENGINEER
DOUBLE GRATE INTAKE WITH MANHOLE		

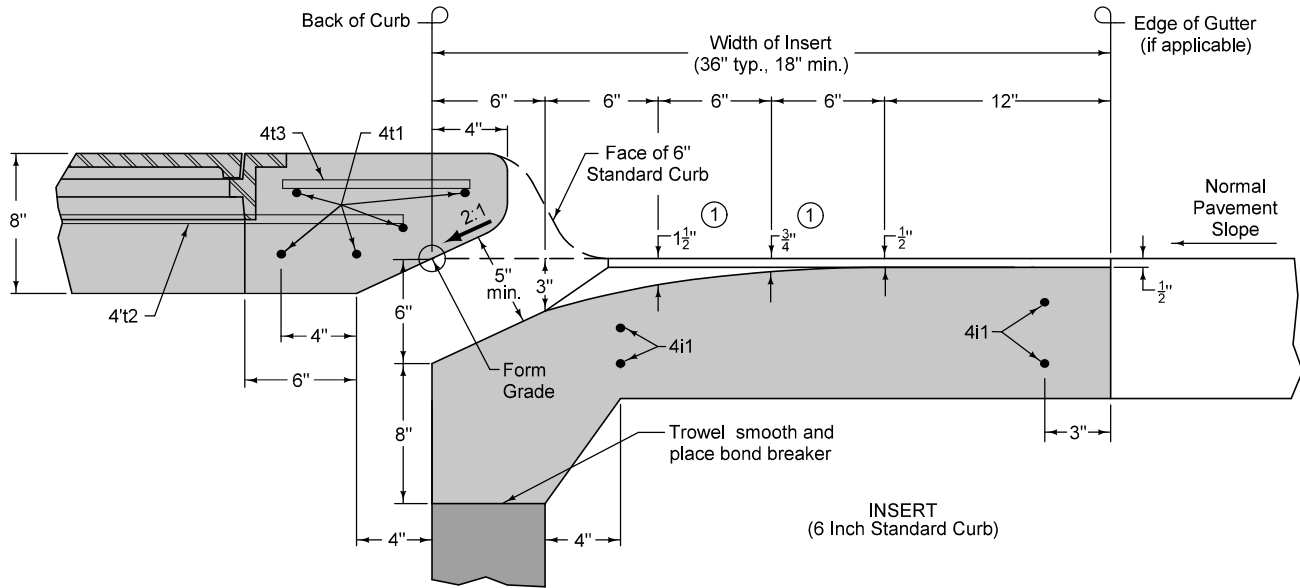

① Insert shaping may be modified for insert widths less than 36 inches. For an 18 inch insert, reduce dimensions indicated by 1/2 inch.

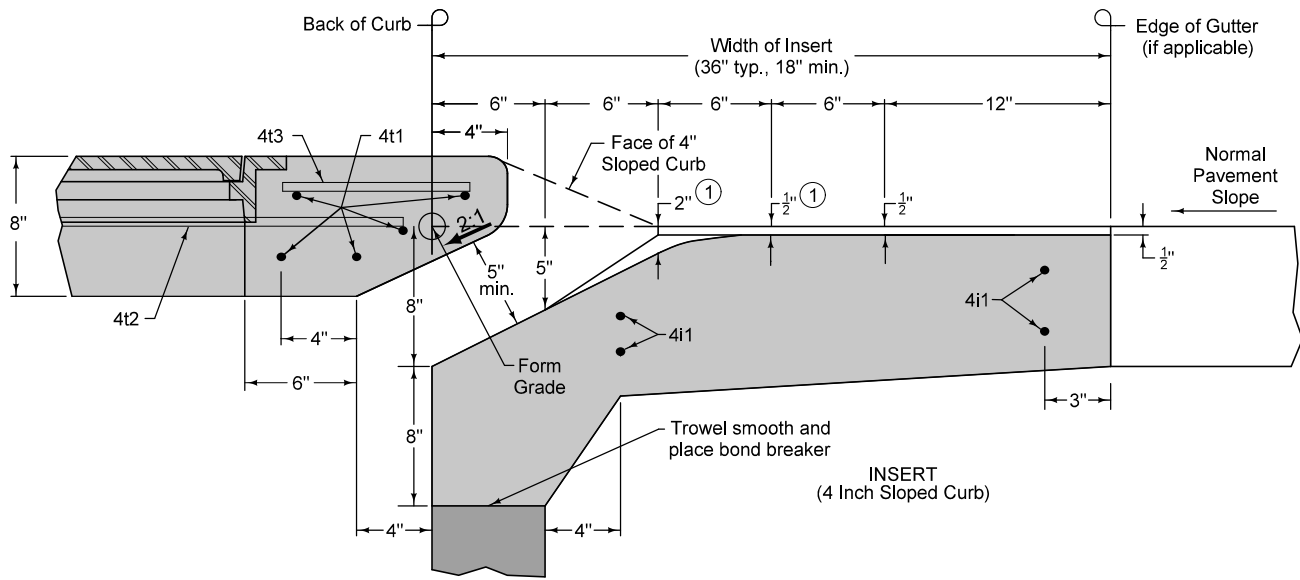
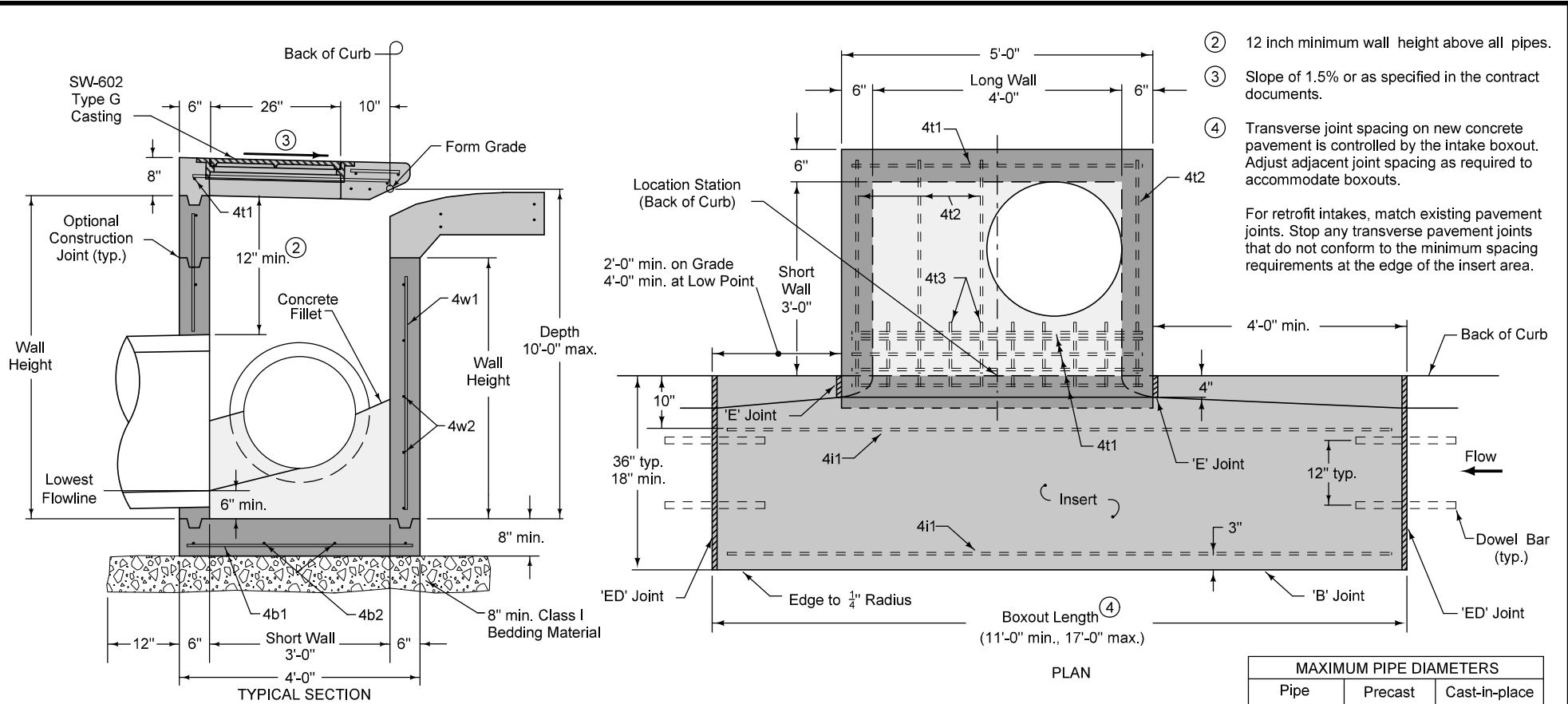

FIGURE 6010.507 SHEET 1 OF 2

SUDAS	IOWADOT	REVISION
		4 04-21-20
FIGURE 6010.507	STANDARD ROAD PLAN	SW-507
		SHEET 1 of 2
REVISIONS: Added Class I Bedding Material and changed maximum box out length to 17'.		
<i>Paul D. Wiegand</i> SUDAS DIRECTOR		<i>Shawn Miller</i> DESIGN METHODS ENGINEER
SINGLE OPEN-THROAT CURB INTAKE, SMALL BOX		



- ② 12 inch minimum wall height above all pipes.
 - ③ Slope of 1.5% or as specified in the contract documents.
 - ④ Transverse joint spacing on new concrete pavement is controlled by the intake boxout. Adjust adjacent joint spacing as required to accommodate boxouts.
- For retrofit intakes, match existing pavement joints. Stop any transverse pavement joints that do not conform to the minimum spacing requirements at the edge of the insert area.

MAXIMUM PIPE DIAMETERS		
Pipe Location	Precast Structure	Cast-in-place Structure
Short Wall	24"	30"
Long Wall	30"	36"

REINFORCING BAR LIST						
Mark	Size	Location	Shape	Count	Length	Spacing
4t1	4	Top	—	6	4'-8"	See Insert
4t2	4	Top	—	4	3'-6"	12"
4t3	4	Top	—	10	10"	6"
4b1	4	Base	—	6	3'-6"	1 1"
4b2	4	Base	—	5	4'-6"	10"
4i1	4	Insert	—	4	Boxout Length minus 8"	See Plan
4w1	4	Walls	—	14	Wall Height minus 4"	14"
4w2	4	Long Walls	—	Varies	4'-8"	12"
4w3	4	Short Walls	—	Varies	3'-8"	12"

SUDAS IOWADOT	FIGURE 6010.507 STANDARD ROAD PLAN	REVISION 4 04-21-20
		SW-507 SHEET 2 of 2
REVISIONS: Added Class I Bedding Material and changed maximum box out length to 17'.		
<i>Paul D. Wigand</i> SUDAS DIRECTOR		<i>Stuart Nade</i> DESIGN METHODS ENGINEER
SINGLE OPEN-THROAT CURB INTAKE, SMALL BOX		

FIGURE 6010.507 SHEET 2 OF 2

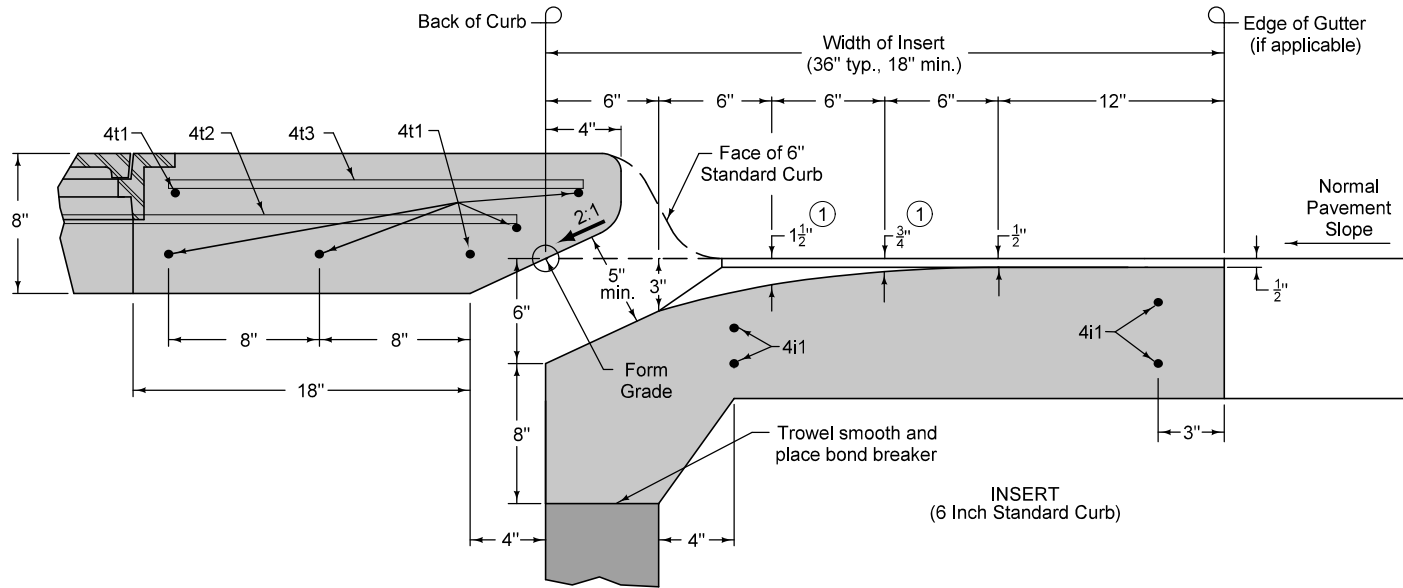

① Insert shaping may be modified for insert widths less than 36 inches. For an 18 inch insert, reduce dimensions indicated by 1/2 inch.

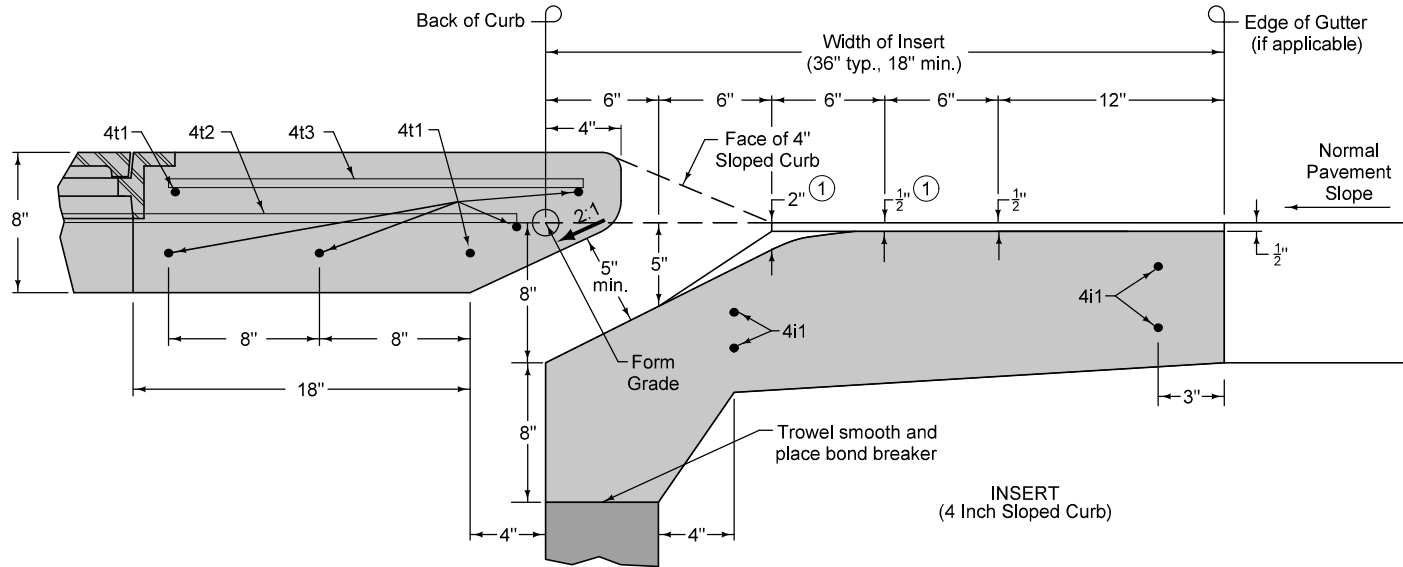
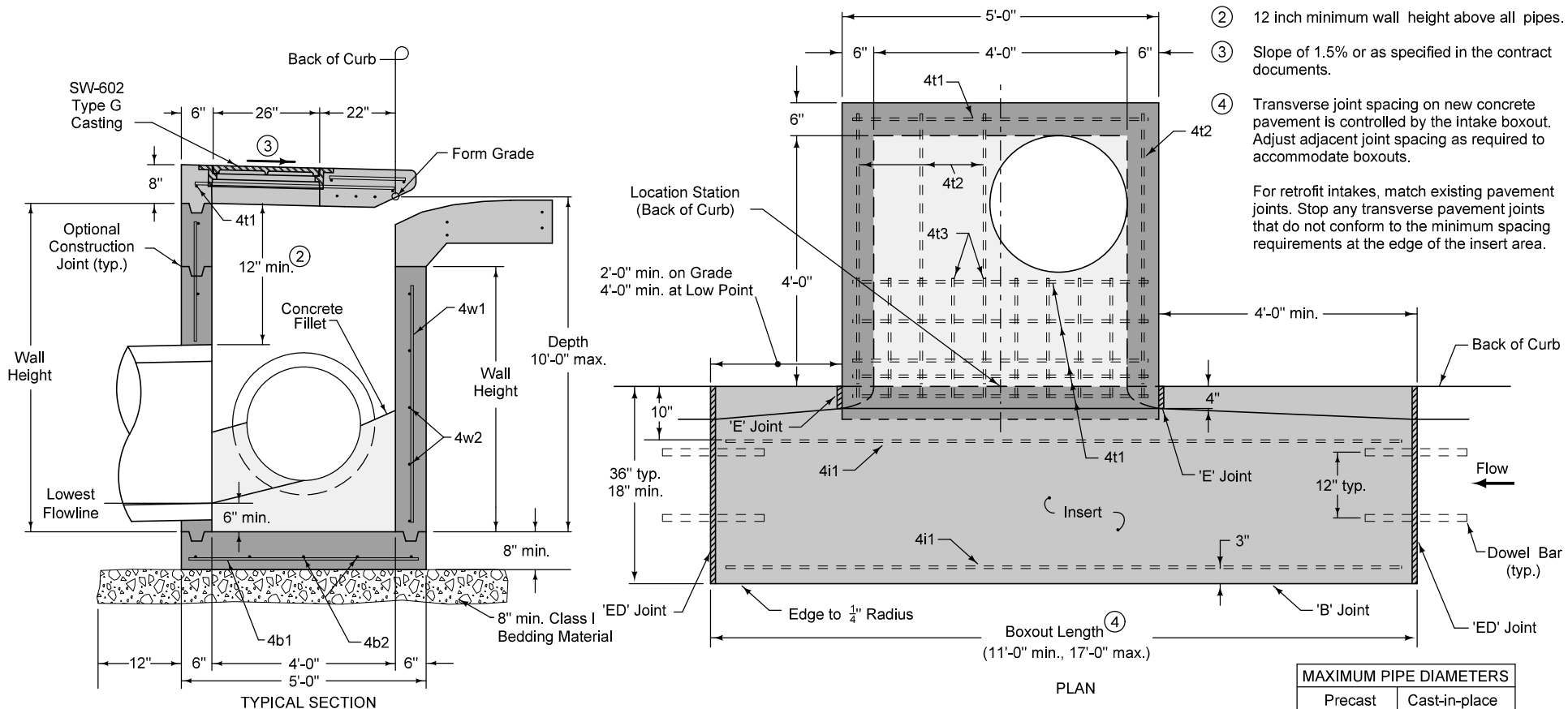

FIGURE 6010.508 SHEET 1 OF 2

SUDAS	IOWADOT	REVISION
		4 04-21-20
FIGURE 6010.508	STANDARD ROAD PLAN	SW-508
		SHEET 1 of 2
REVISIONS: Added Class I Bedding Material and changed maximum box out length to 17".		
Paul D. Wigand SUDAS DIRECTOR		Shawn Miller DESIGN METHODS ENGINEER
SINGLE OPEN-THROAT CURB INTAKE, LARGE BOX		



- ② 12 inch minimum wall height above all pipes.
 - ③ Slope of 1.5% or as specified in the contract documents.
 - ④ Transverse joint spacing on new concrete pavement is controlled by the intake boxout. Adjust adjacent joint spacing as required to accommodate boxouts.
- For retrofit intakes, match existing pavement joints. Stop any transverse pavement joints that do not conform to the minimum spacing requirements at the edge of the insert area.

REINFORCING BAR LIST						
Mark	Size	Location	Shape	Count	Length	Spacing
4t1	4	Top	—	7	4'-8"	See Insert
4t2	4	Top	—	4	4'-6"	12"
4t3	4	Top	—	10	1'-10"	6"
4b1	4	Base	—	6	4'-6"	11"
4b2	4	Base	—	6	4'-6"	11"
4i1	4	Insert	—	4	Boxout Length minus 8"	See Plan
4w1	4	Walls	—	16	Wall Height minus 4"	14"
4w2	4	Walls	—	Varies	4'-8"	12"
4w3	4	Walls	—	Varies	4'-8"	12"

MAXIMUM PIPE DIAMETERS	
Precast Structure	Cast-in-place Structure
30"	36"

SUDAS IOWADOT	REVISION 4 04-21-20
	SW-508 SHEET 2 of 2
REVISIONS: Added Class I Bedding Material and changed maximum box out length to 17'.	
<i>Paul D. Wigand</i> SUDAS DIRECTOR	
<i>Stuart Nade</i> DESIGN METHODS ENGINEER	
SINGLE OPEN-THROAT CURB INTAKE, LARGE BOX	

FIGURE 6010.508 SHEET 2 OF 2

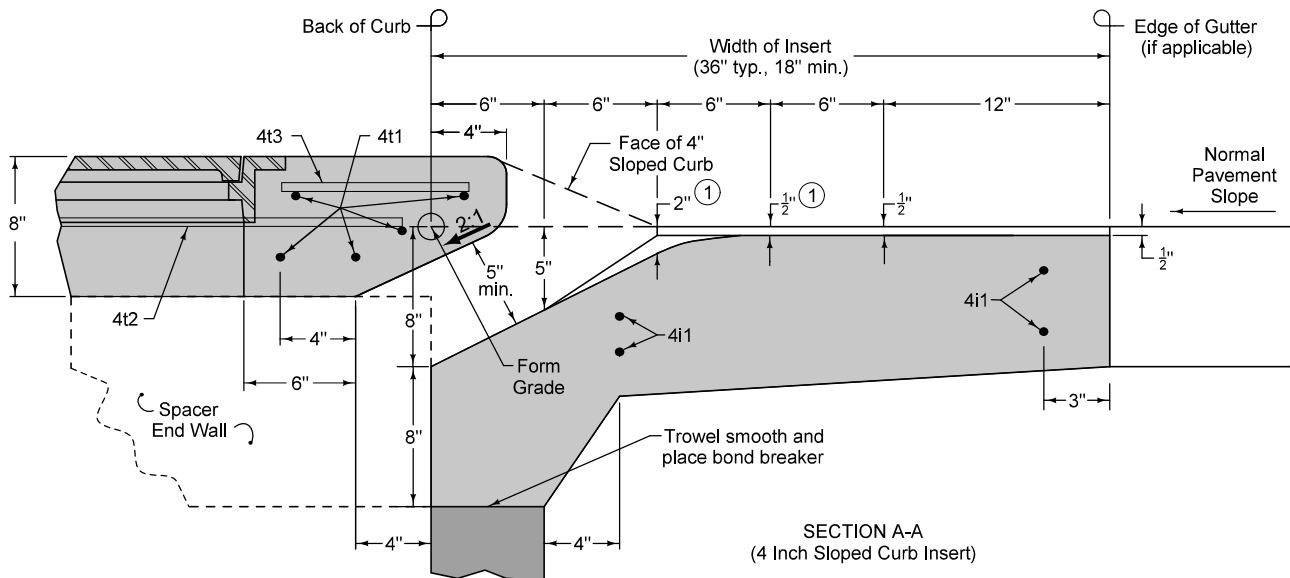
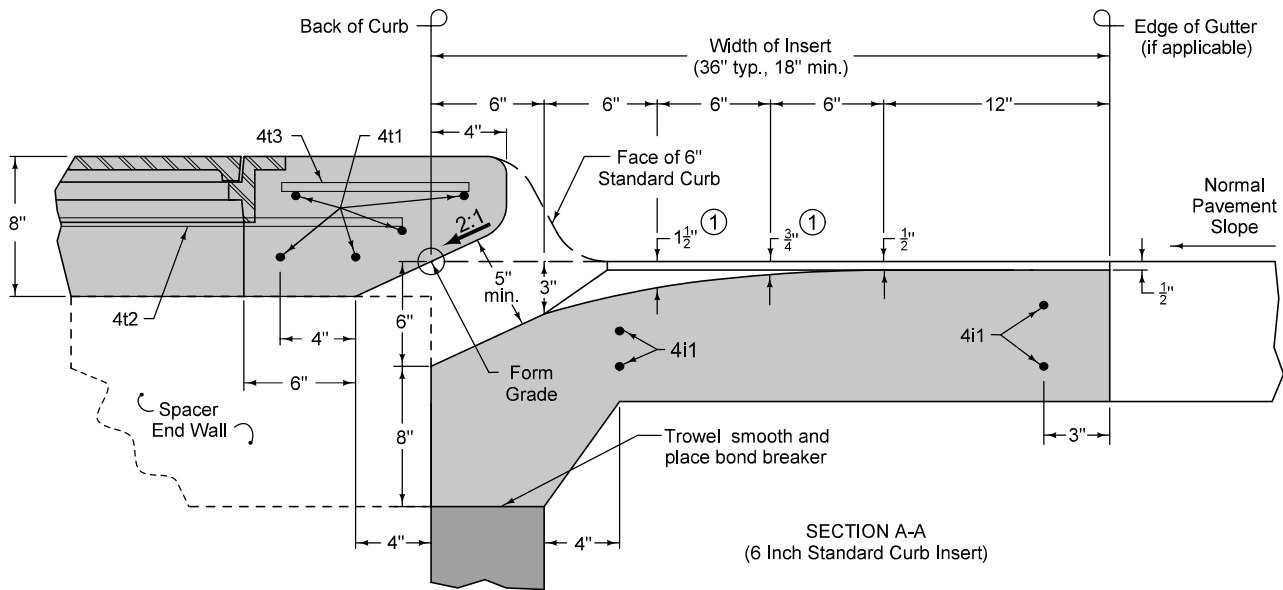

SUDAS	IOWADOT	REVISION
		6 04-21-20
FIGURE 6010.509	STANDARD ROAD PLAN	SW-509
		SHEET 1 of 3
REVISIONS: Added Class 1 Bedding Material and changed maximum box out length to 17'.		
Paul D. Wigand SUDAS DIRECTOR		Steve Nadeau DESIGN METHODS ENGINEER
DOUBLE OPEN-THROAT CURB INTAKE, SMALL BOX		

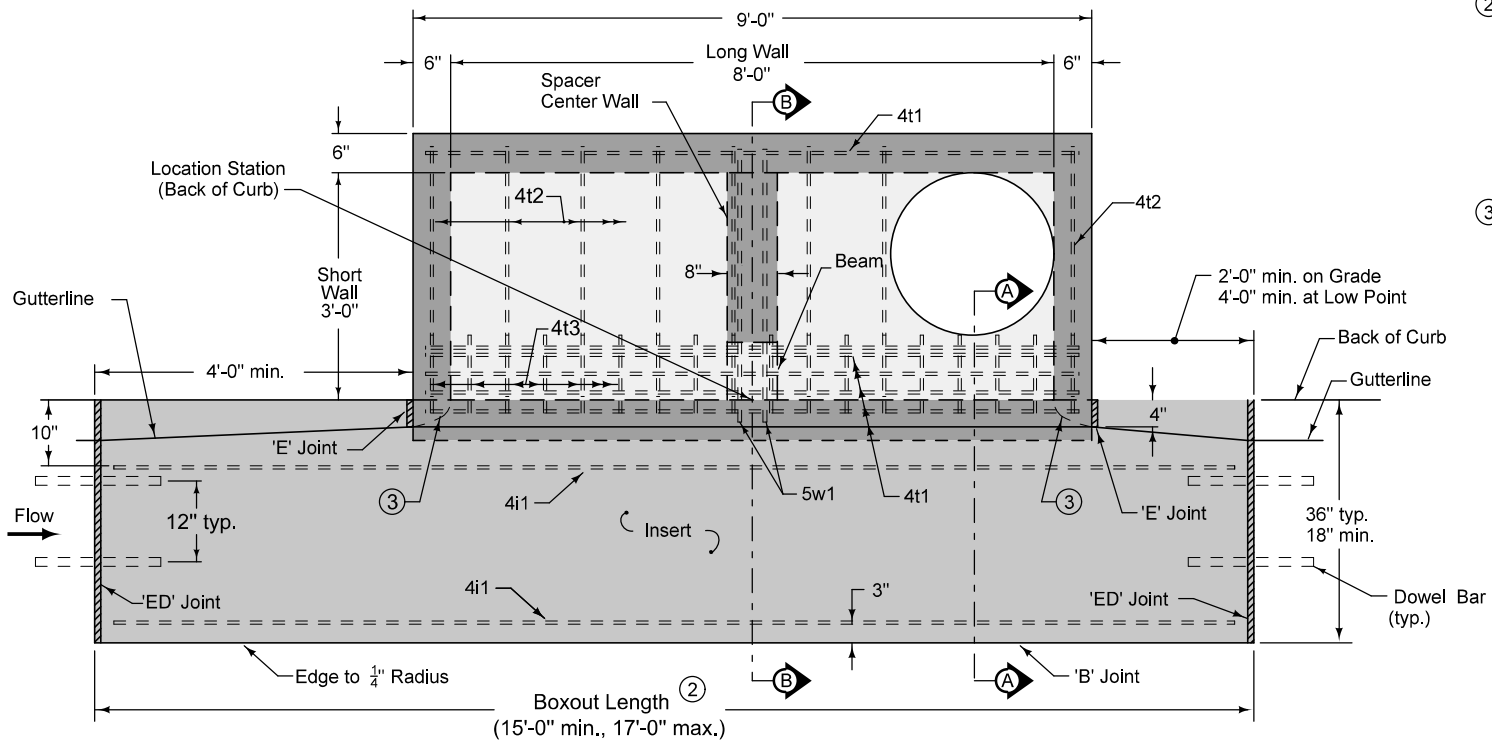

PLAN

② Transverse joint spacing on new concrete pavement is controlled by the intake boxout. Adjust adjacent joint spacing as required to accommodate boxouts.

For retrofit intakes, match existing pavement joints. Stop any transverse pavement joints that do not conform to the minimum spacing requirements at the edge of the insert area.

③ Rounded shaping at inlet.

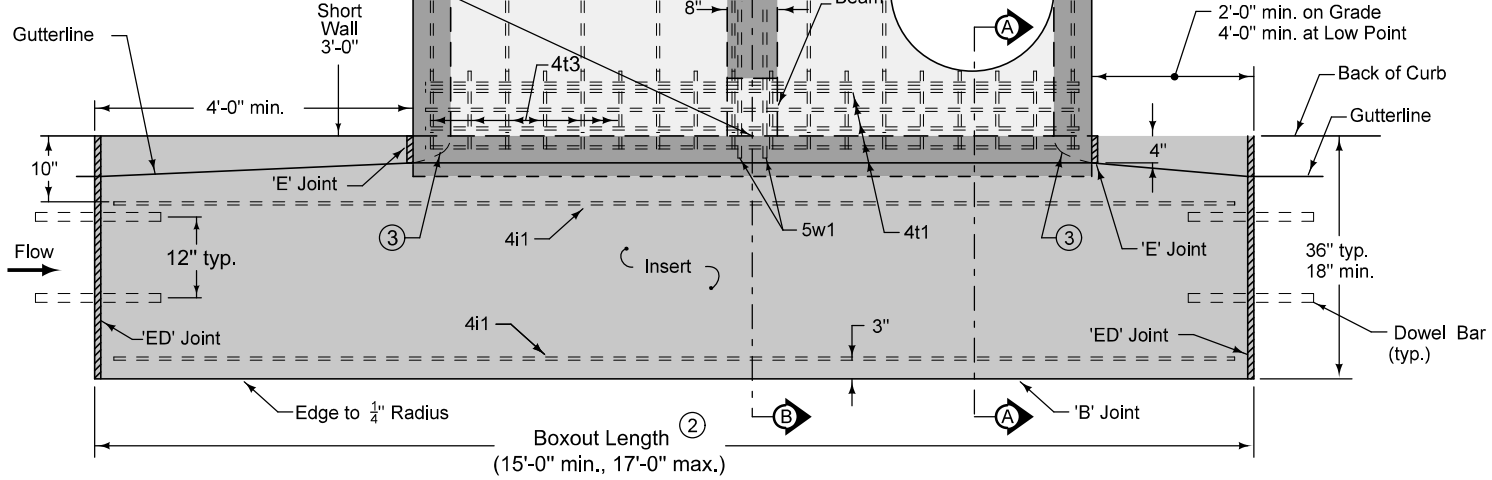

REINFORCING BAR LIST

Mark	Size	Location	Shape	Count	Length	Spacing
4b1	4	Base	—	9	3'-6"	12"
4b2	4	Base	—	5	8'-6"	10"
4i1	4	Insert	—	4	Boxout Length minus 8"	See Insert
4t1	4	Top	—	6	8'-6"	See Plan
4t2	4	Top	—	8	3'-6"	12"
4t3	4	Top	—	18	10"	6"
4w1	4	Walls	—	22	Wall Height minus 4"	13"
4w2	4	Long Walls	—	Varies	4'-8"	12"
4w3	4	Short Walls	—	Varies	3'-8"	12"
5w1	5	Beam	⌊	2	7'-3"	4"

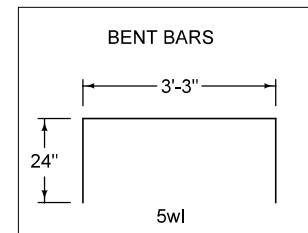

SUDAS IOWADOT	REVISION	6	04-21-20
	FIGURE 6010.509 STANDARD ROAD PLAN	SW-509 SHEET 2 of 3	
REVISIONS: Added Class I Bedding Material and changed maximum box out length to 17'.			
<i>Paul D. Wrigand</i> SUDAS DIRECTOR		<i>Shawn Miller</i> DESIGN METHODS ENGINEER	
DOUBLE OPEN-THROAT CURB INTAKE, SMALL BOX			

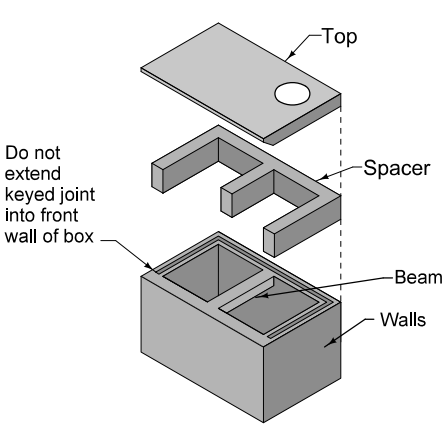
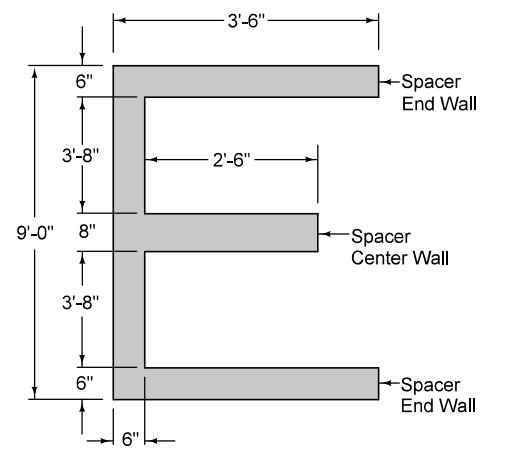
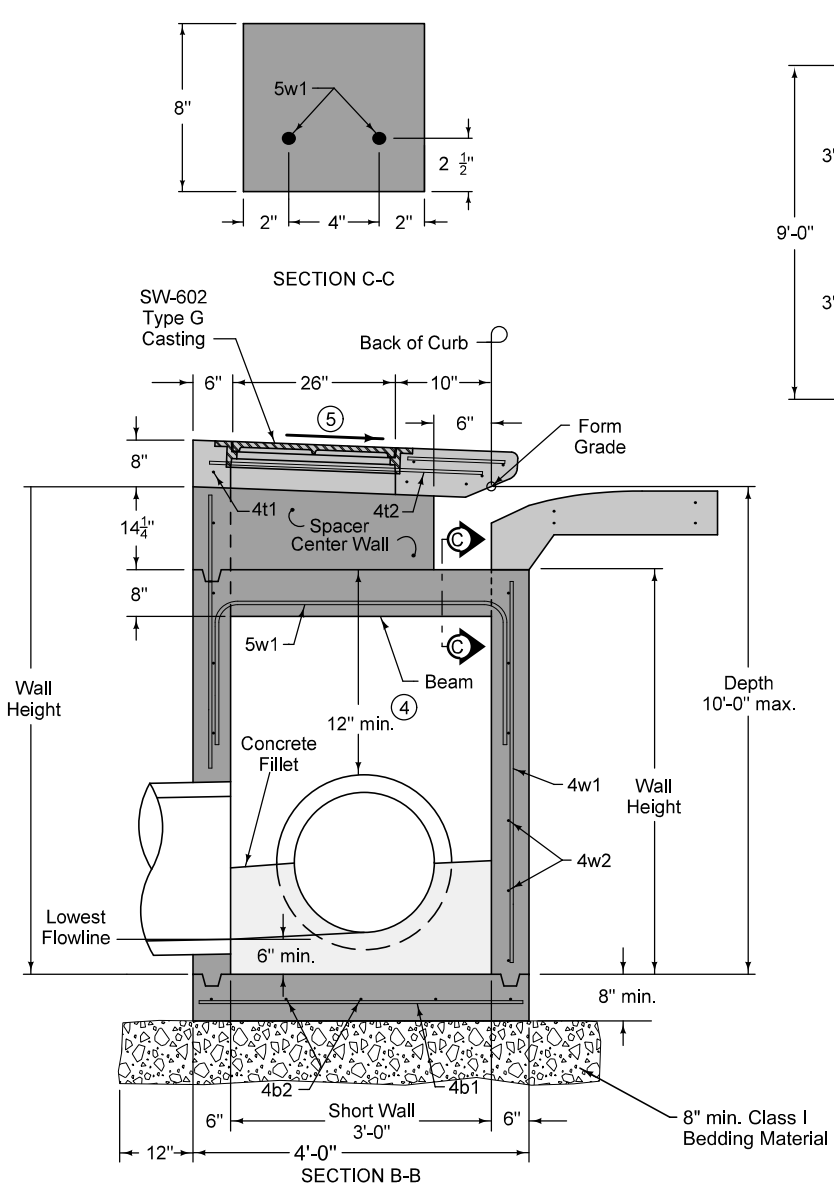

ISOMETRIC
(Refer to SECTION B-B for alignment of Top with Spacer)

- ④ 12 inch minimum wall height above all pipes.
- ⑤ Slope of 1.5% or as specified in the contract documents.

MAXIMUM PIPE DIAMETERS		
Pipe Location	Precast Structure	Cast-in-place Structure
Short Wall	24"	30"
Long Wall	60"	66"

FIGURE 6010.509 SHEET 3 OF 3

SUDAS	IOWADOT	REVISION
		6 04-21-20
FIGURE 6010.509	STANDARD ROAD PLAN	SW-509
		SHEET 3 of 3
REVISIONS: Added Class I Bedding Material and changed maximum box out length to 17'.		
Paul D. Wiegand SUDAS DIRECTOR		Steve Nadeau DESIGN METHODS ENGINEER
DOUBLE OPEN-THROAT CURB INTAKE, SMALL BOX		

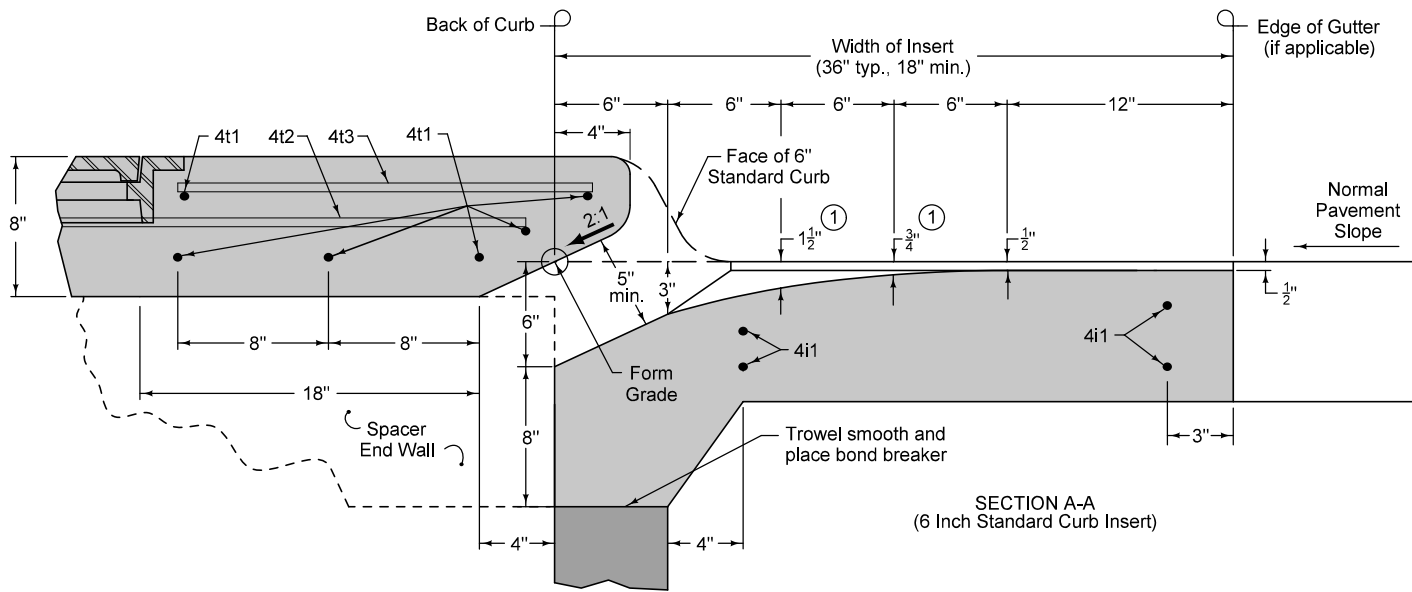

① Insert shaping may be modified for insert widths less than 36 inches. For an 18 inch insert, reduce dimensions indicated by 1/4 inch.

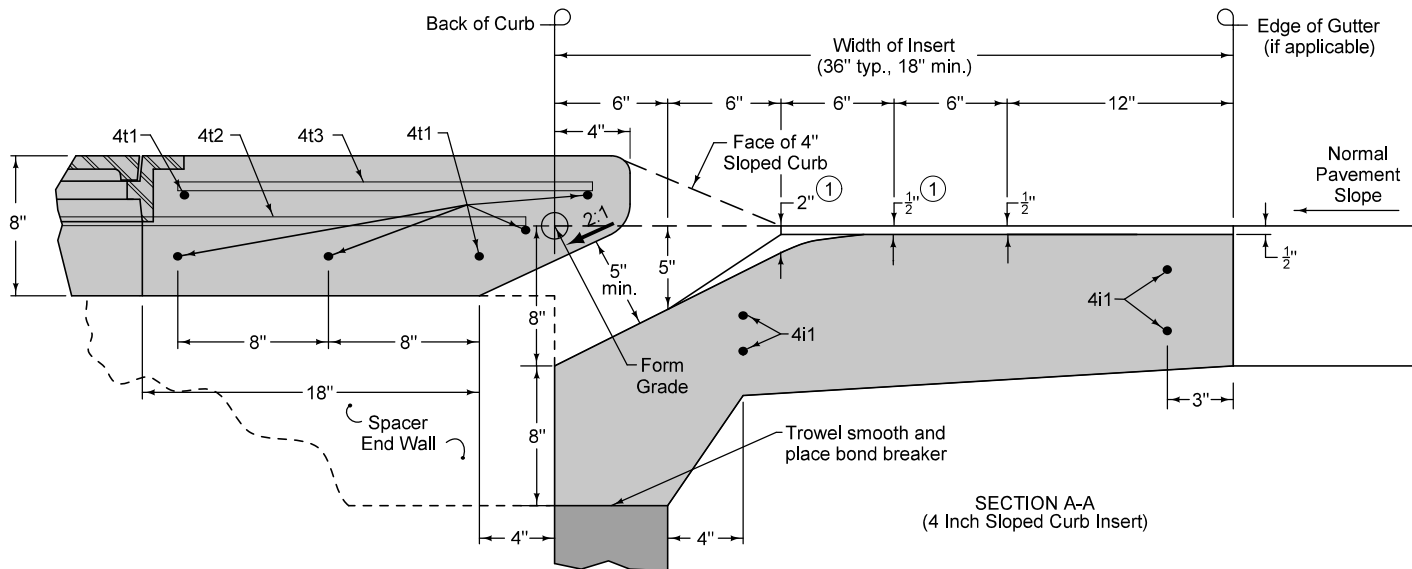
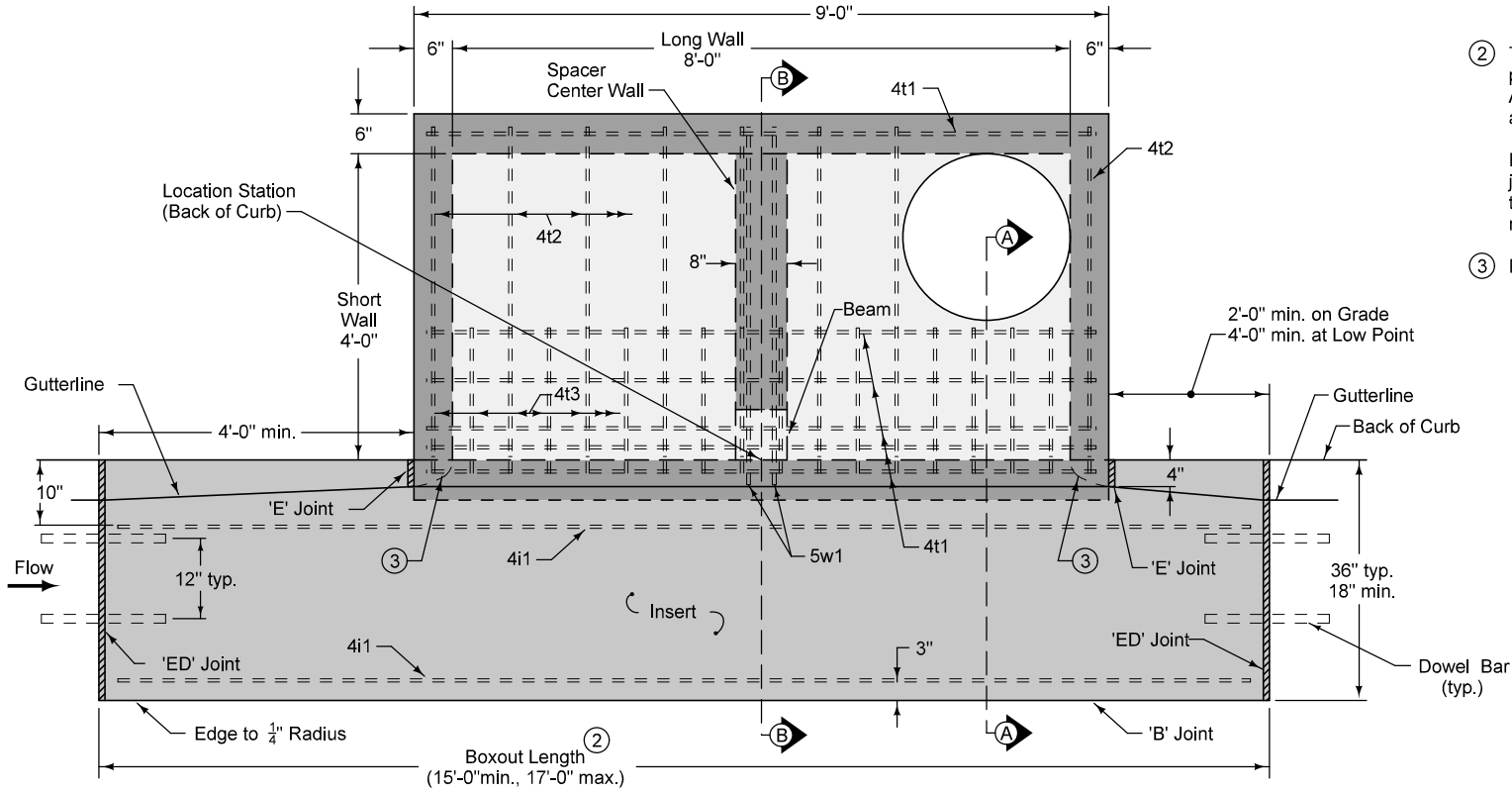

FIGURE 6010.510 SHEET 1 OF 3

SUDAS IOWADOT	REVISION	6	04-21-20
	FIGURE 6010.510	STANDARD ROAD PLAN	SW-510
REVISIONS: Added Class 1 Bedding Material and changed maximum box out length to 17'.			SHEET 1 of 3
Paul D. Wigand SUDAS DIRECTOR		Stuart Nadeau DESIGN METHODS ENGINEER	
DOUBLE OPEN-THROAT CURB INTAKE, LARGE BOX			



PLAN

REINFORCING BAR LIST						
Mark	Size	Location	Shape	Count	Length	Spacing
4b1	4	Base	—	9	4'-6"	12"
4b2	4	Base	—	6	8'-6"	11"
4i1	4	Insert	—	4	Boxout Length minus 8"	See Insert
4t1	4	Top	—	7	8'-6"	See Plan
4t2	4	Top	—	8	4'-4"	12"
4t3	4	Top	—	18	1'-10"	6"
4w1	4	Walls	—	24	Wall Height minus 4"	13"
4w2	4	Long Walls	—	Varies	4'-8"	12"
4w3	4	Short Walls	—	Varies	8'-8"	12"
5w1	5	Beam	⌊	2	8'-3"	4"

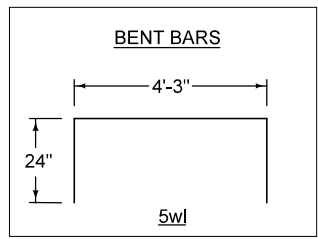

- ② Transverse joint spacing on new concrete pavement is controlled by the intake boxout. Adjust adjacent joint spacing as required to accommodate boxouts.
- For retrofit intakes, match existing pavement joints. Stop any transverse pavement joints that do not conform to the minimum spacing requirements at the edge of the insert area.
- ③ Rounded shaping at inlet.

SUDAS IOWADOT	REVISION	6	04-21-20
	FIGURE 6010.510	STANDARD ROAD PLAN	SW-510
REVISIONS: Added Class I Bedding Material and changed maximum box out length to 17'.		SHEET 2 of 3	
Paul D. Wiegand SUDAS DIRECTOR		Stuart Miller DESIGN METHODS ENGINEER	
DOUBLE OPEN-THROAT CURB INTAKE, LARGE BOX			

FIGURE 6010.510 SHEET 2 OF 3

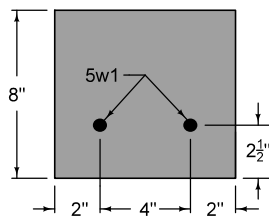

SECTION C-C

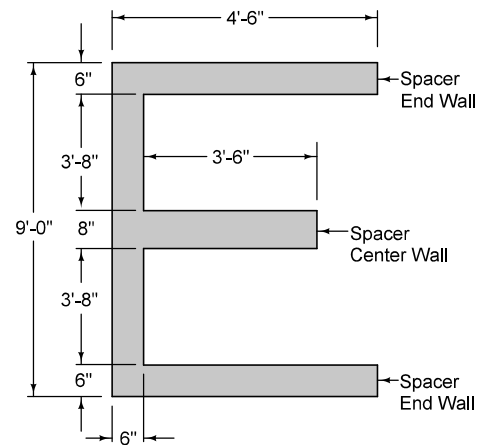

PLAN (SPACER)

- ④ 12 inch minimum wall height above all pipes.
- ⑤ Slope of 1.5% or as specified in the contract documents.

MAXIMUM PIPE DIAMETERS		
Pipe Location	Precast Structure	Cast-in-place Structure
Short Wall	30"	36"
Long Wall	60"	66"

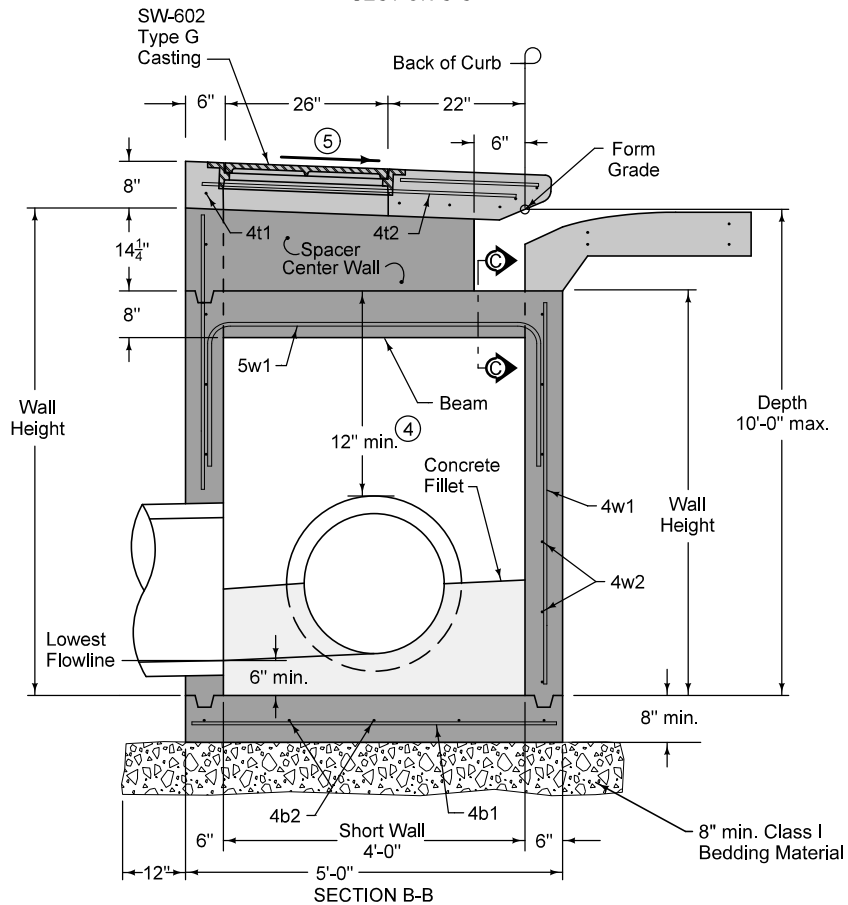

SECTION B-B

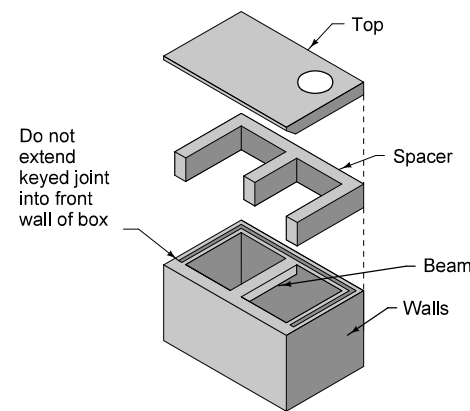

ISOMETRIC
(Refer to Section B-B for alignment of Top with Spacer)

SUDAS	IOWADOT	REVISION
		6 04-21-20
FIGURE 6010.510	STANDARD ROAD PLAN	SW-510
		SHEET 3 of 3
REVISIONS: Added Class I Bedding Material and changed maximum box out length to 17'.		
<i>Paul D. Weigand</i> SUDAS DIRECTOR		<i>Stuart Nadeau</i> DESIGN METHODS ENGINEER
DOUBLE OPEN-THROAT CURB INTAKE, LARGE BOX		

FIGURE 6010.510 SHEET 3 OF 3

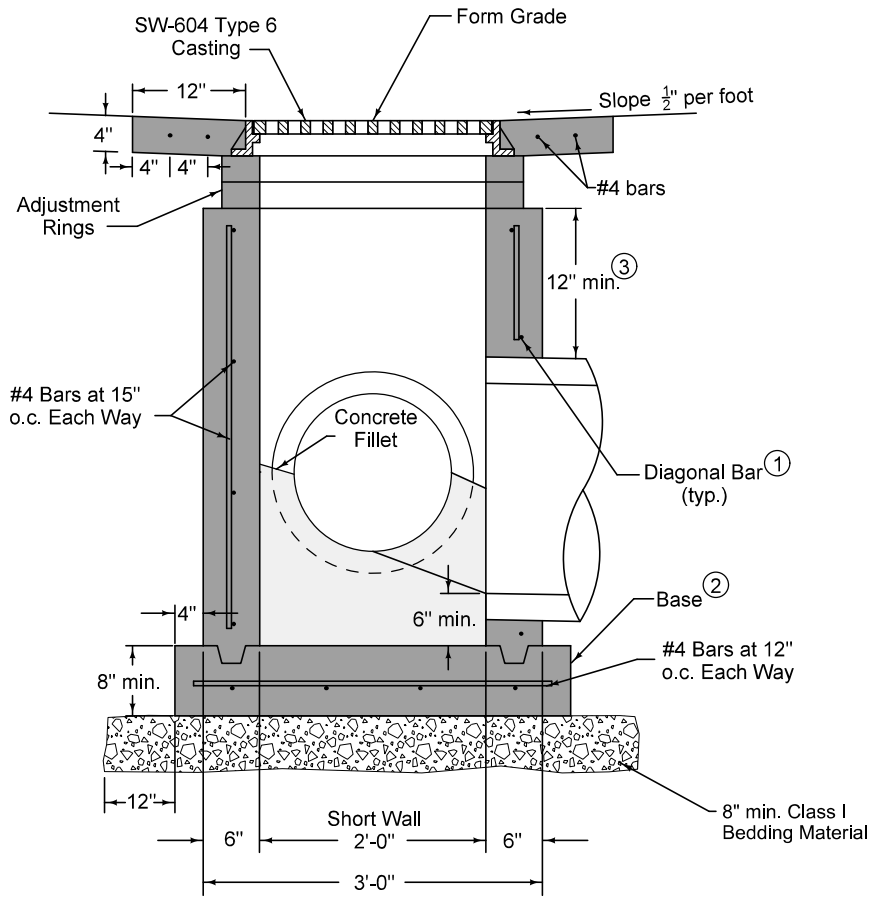

SECTION A-A

- ① Install four #4 diagonal bars at all pipe openings.
- ② Cast-in-place base shown. If base is precast integral with walls, the footprint of the base is not required to extend beyond the outer edge of the walls.
- ③ 12 inch minimum wall height above all pipes.

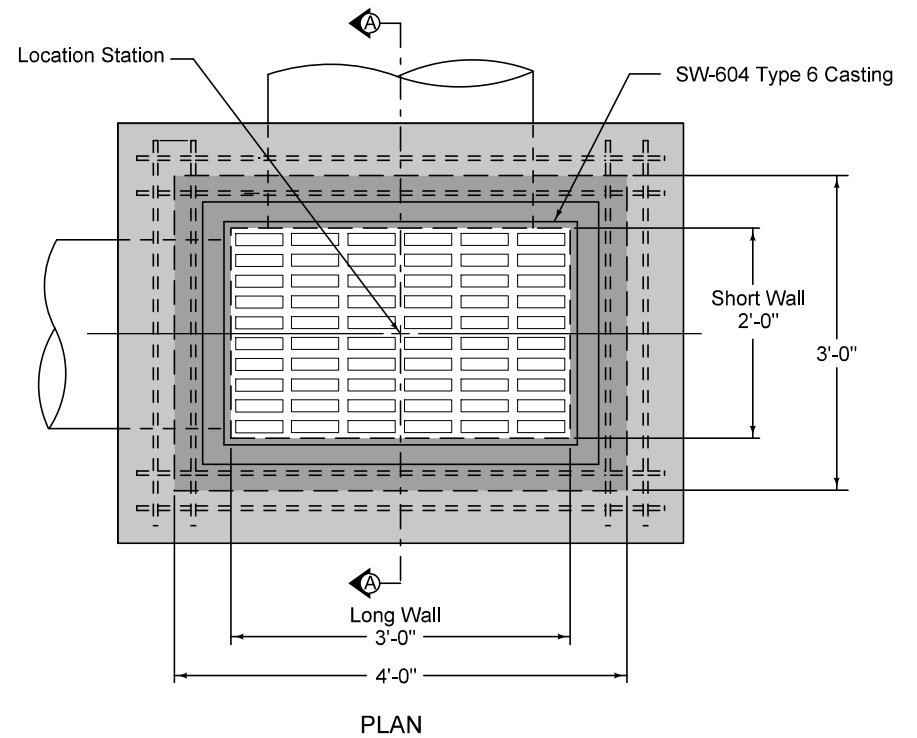

PLAN

MAXIMUM PIPE DIAMETERS		
Pipe Location	Precast Structure	Cast-in-place Structure
Short Wall	15"	18"
Long Wall	24"	30"

SUDAS IOWADOT	REVISION 2 04-21-20
	SW-511 SHEET 1 of 1
REVISIONS: Added Class I Bedding Material.	
<i>Paul D. Wiegand</i> SUDAS DIRECTOR	
<i>Stuart Nade</i> DESIGN METHODS ENGINEER	
RECTANGULAR AREA INTAKE	

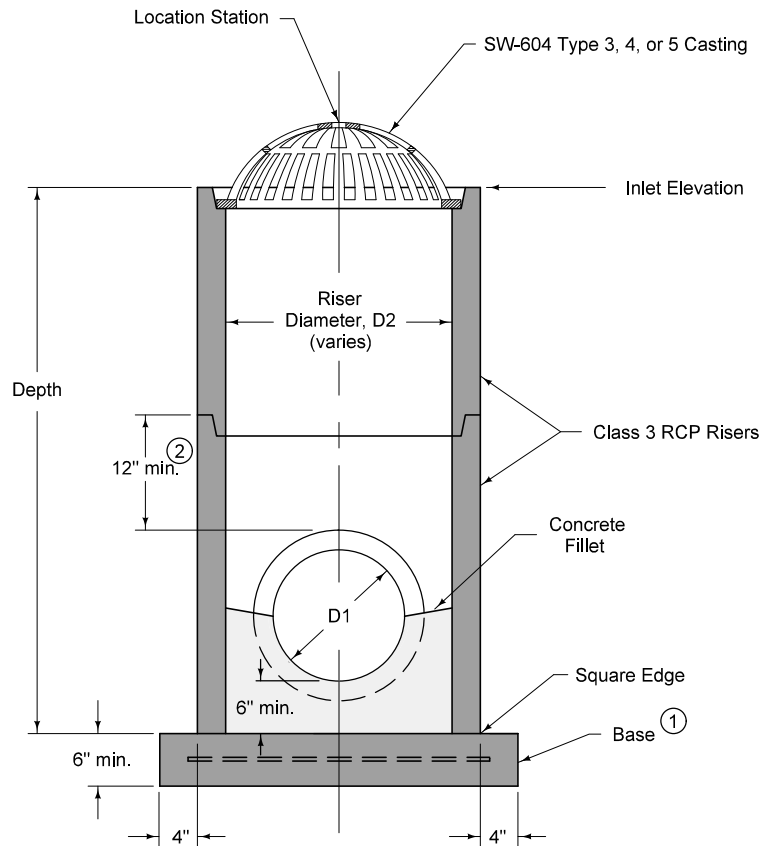

TYPICAL SECTION

CASE 1

- ① Precast (shown) or cast-in-place base:
 - Precast: 6 inch thick concrete with #6 welded wire mesh on 4 inch centers (WWF 4" x 4"). Center mesh vertically within base.
 - Cast-in-place: 8 inch thick non-reinforced concrete.
- ② 12 inch minimum riser height above all pipes.

INTAKE SIZE - CASE 1	
Outlet Pipe Diameter, D1	Minimum Riser Diameter, D2
12"	18"
15"	24"
18"	24"
21"	30"
24"	30"
27"	36"

FIGURE 6010.512 SHEET 1 OF 2

SUDAS	IOWADOT	REVISION
		4 04-21-20
FIGURE 6010.512	STANDARD ROAD PLAN	SW-512
		SHEET 1 of 2
REVISIONS: Changed 1 to I on Bedding Material		
Paul D. Wigand SUDAS DIRECTOR		Shawn Miller DESIGN METHODS ENGINEER
CIRCULAR AREA INTAKE		

③ Minimum riser diameter is 18 inches.

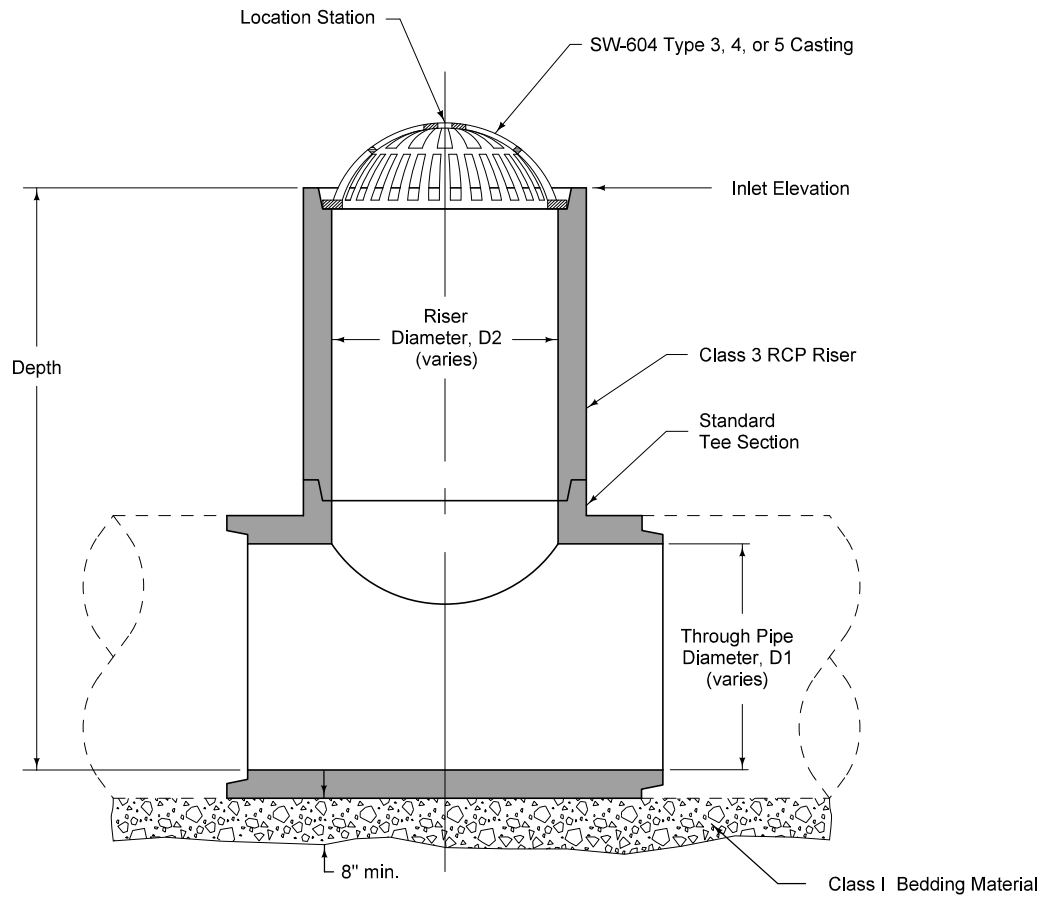

TYPICAL SECTION

CASE 2

INTAKE SIZE - CASE 2	
Through Pipe Diameter, D1	Maximum Riser Diameter, D2 ③
18"	18"
21"	18"
24"	24"
27"	24"
30"	30"
36" or more	36"

SUDAS	IOWADOT	REVISION
		4 04-21-20
FIGURE 6010.512	STANDARD ROAD PLAN	SW-512
		SHEET 2 of 2

REVISIONS: Changed 1 to I on Bedding Material

Paul D. Wigand
 SUDAS DIRECTOR

Stuart M. Nelson
 DESIGN METHODS ENGINEER

CIRCULAR AREA INTAKE

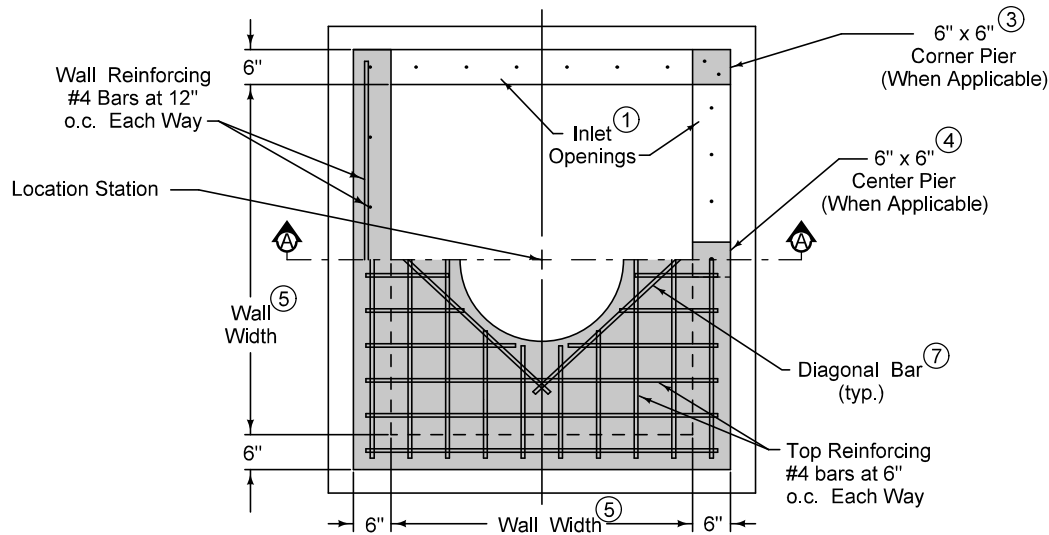

PLAN

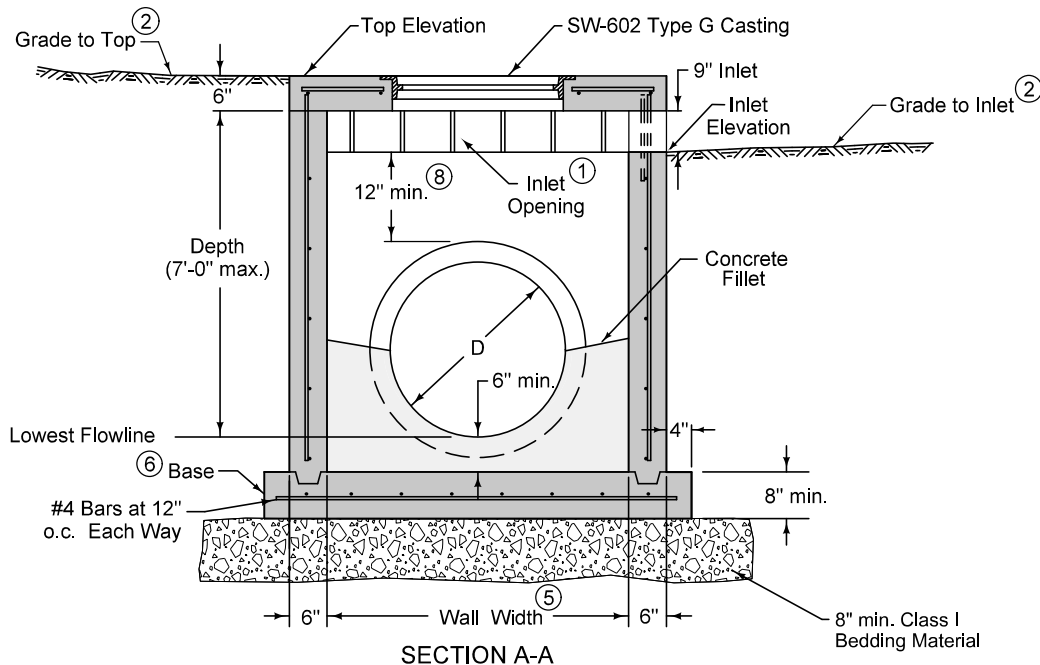

SECTION A-A

Structure may be built with openings on any or all sides. Provide openings and orientation as specified in the contract documents.

Adjacent walls may have different widths based upon pipe configuration, but structure must be rectangular.

- ① Construct inlet openings with 15 inch #4 epoxy coated bars at 8 inches on center. Embed bars a minimum of 3 inches into walls and top at all openings.
- ② Grade to inlet elevation on open sides. Grade to top elevation on closed sides.
- ③ Corner pier required between openings of two adjacent walls. Extend wall reinforcing vertically through pier. Install one additional 15 inch #4 bar in pier.
- ④ Center pier required at center of any inlet opening with length of 5 feet or greater. Extend wall reinforcing vertically through pier. Install one additional 15 inch #4 bar in pier.
- ⑤ Wall widths vary with pipe diameter. Provide 6 inches of wall width (minimum) each side of pipe opening. Minimum wall width is 36 inches. Maximum wall width is 72 inches.
- ⑥ Cast-in-place base shown. If base is precast integral with walls, the footprint of base is not required to extend beyond the outer edge of the walls.
- ⑦ Install four #4 diagonal bars at all pipe openings.
- ⑧ 12 inch minimum wall height above all pipes.

FIGURE 6010.513 SHEET 1 OF 1

SUDAS	IOWADOT	REVISION	
		3	04-20-21
FIGURE 6010.513	STANDARD ROAD PLAN	SW-513	
REVISIONS: Modified circle notes 1, 3, 4 and 8.		SHEET 1 of 1	
Paul D. Wigand SUDAS DIRECTOR		Stuart M. Nade DESIGN METHODS ENGINEER	
OPEN-SIDED AREA INTAKE			

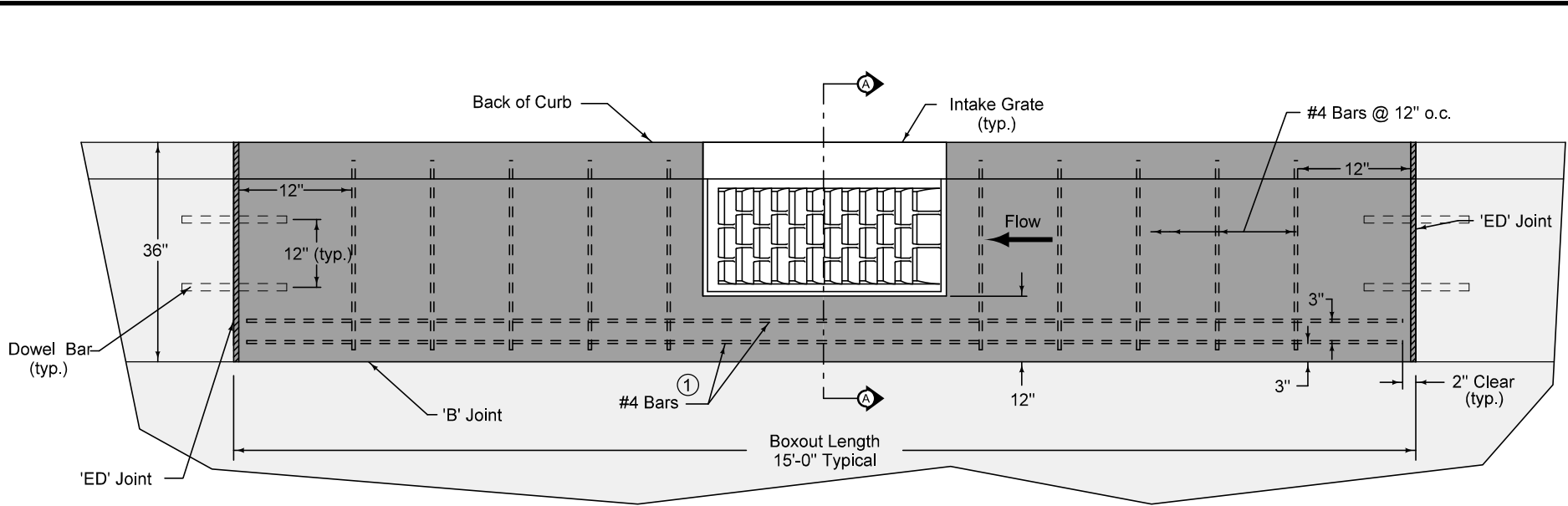

BOXOUT IN PCC PAVEMENT AND PCC BASE WITH HMA OVERLAY

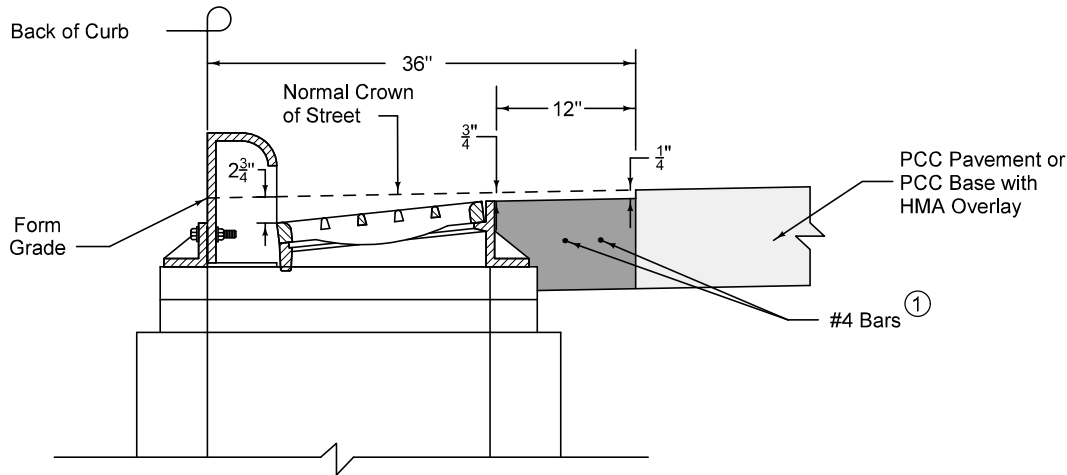

SECTION A-A

Transverse joint spacing on new concrete pavement is controlled by the intake boxout. Adjust adjacent joint spacing as required to accommodate boxouts.

For retrofit intakes, match existing concrete pavement joints. Stop any transverse pavement joints that do not conform to the minimum spacing requirements at the edge of the boxout.

① Center bars vertically within slab.

FIGURE 6010.514 SHEET 1 OF 3

		REVISION
		1 04-17-18
FIGURE 6010.514	STANDARD ROAD PLAN	SW-514
		SHEET 1 of 3
<small>REVISIONS: Added dimension to back of grate. Updated line work and Iowa DOT and SUDAS logos.</small>		
<i>Paul D. Wigand</i> <small>SUDAS DIRECTOR</small>		<i>Brian Smith</i> <small>DESIGN METHODS ENGINEER</small>
BOXOUT FOR GRATE INTAKES		

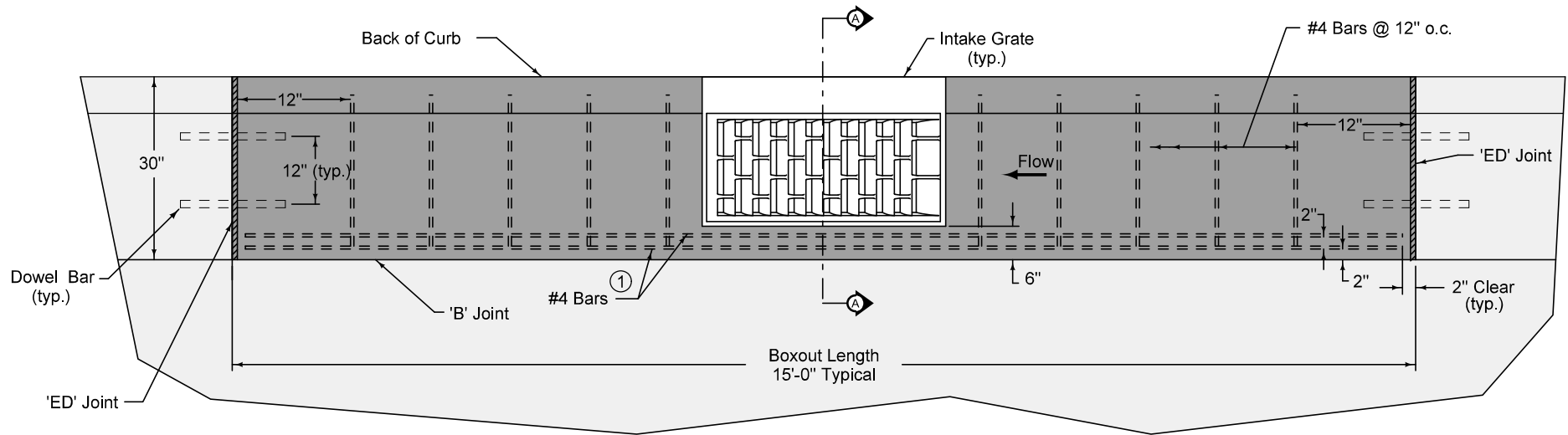

BOXOUT IN PCC CURB AND GUTTER

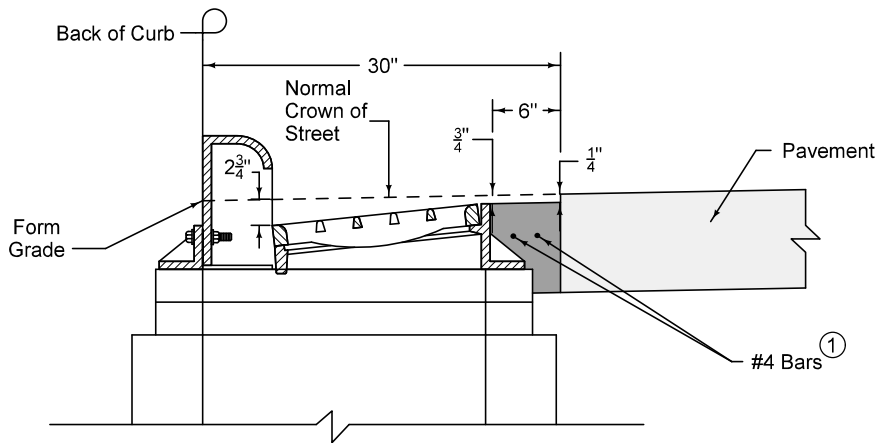

SECTION A-A

① Center bars vertically within slab.

FIGURE 6010.514 SHEET 2 OF 3

SUDAS	IOWADOT	REVISION	
		1	04-17-18
FIGURE 6010.514	STANDARD ROAD PLAN	SW-514	
REVISIONS: Added dimension to back of grate. Updated line work and Iowa DOT and SUDAS logos.		SHEET 2 of 3	
Paul D. Wigand SUDAS DIRECTOR		Brian Smith DESIGN METHODS ENGINEER	
BOXOUT FOR GRATE INTAKES			

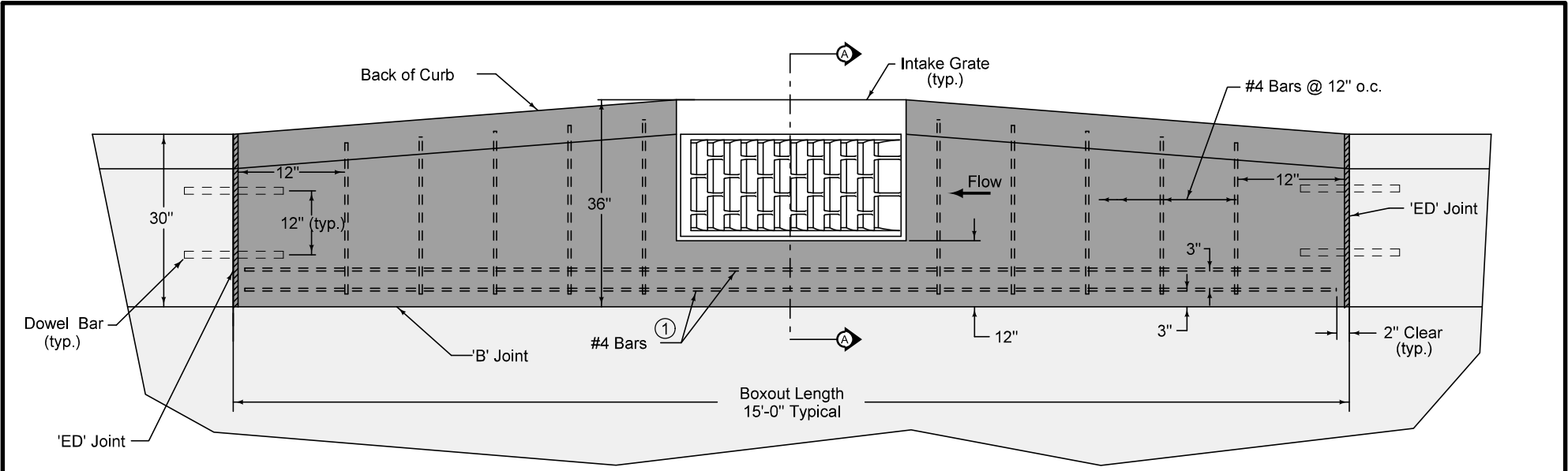

ALTERNATE BOXOUT IN PCC CURB AND GUTTER

Transverse joint spacing on new concrete pavement is controlled by the intake boxout. Adjacent joint spacing may need to be field adjusted to fit boxouts.

For retrofit intakes, match existing concrete pavement joints. Stop any transverse pavement joints that do not conform to the minimum spacing requirements at the edge of the boxout.

- ① Center bars vertically within slab.

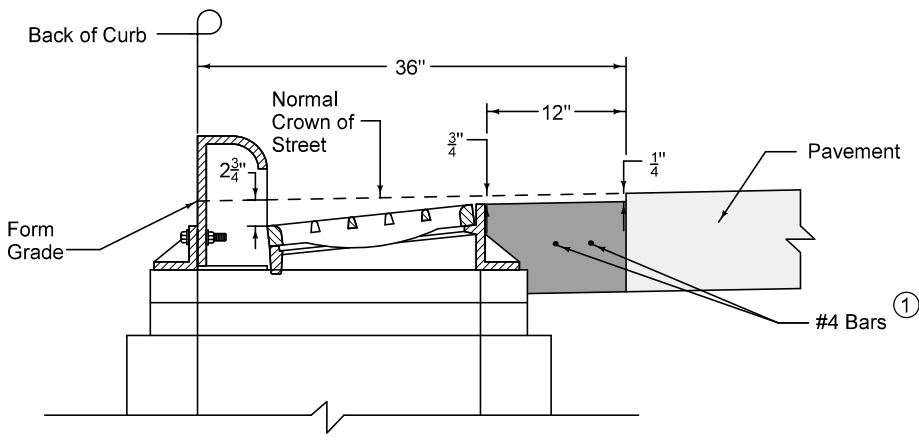

SECTION A-A

FIGURE 6010.514 SHEET 3 OF 3

		REVISION
		1 04-17-18
FIGURE 6010.514	STANDARD ROAD PLAN	SW-514
		SHEET 3 of 3
<small>REVISIONS: Added dimension to back of grate. Updated line work and Iowa DOT and SUDAS logos.</small>		
<i>Paul D. Wigand</i> <small>SUDAS DIRECTOR</small>		<i>Brian Smith</i> <small>DESIGN METHODS ENGINEER</small>
BOXOUT FOR GRATE INTAKES		

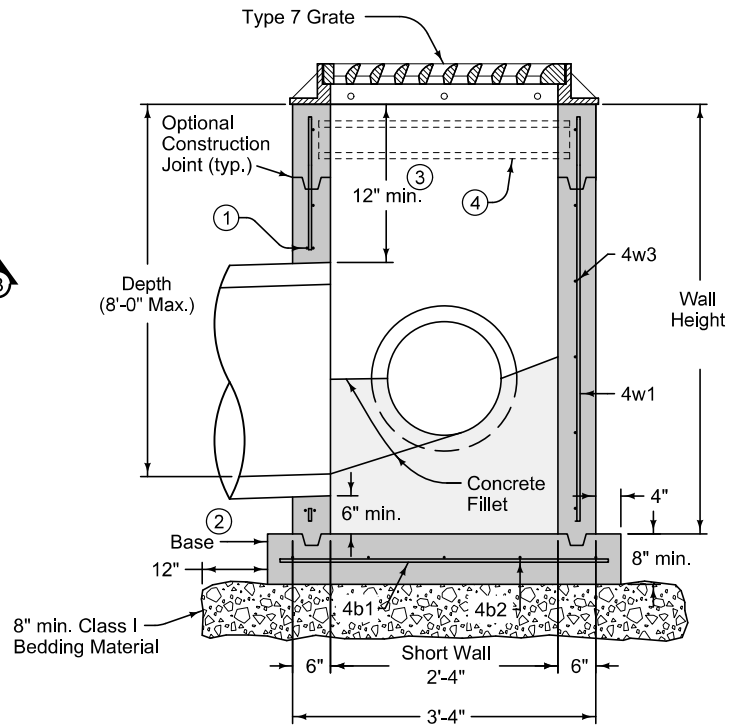
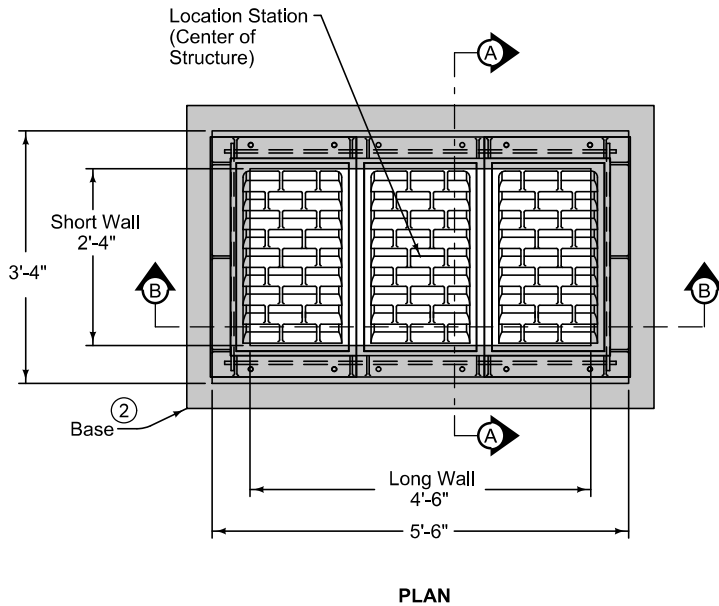

- ① Provide two #4 hoop bars at all pipe openings.
- ② Cast-in-place base shown. If base is precast integral with walls, the footprint of the base is not required to extend beyond the outer edge of the walls.
- ③ 12 inch minimum wall height above all pipes.
- ④ If required by casting manufacturer, provide support beam under all frame joints. Modify structure walls as required to provide pocket for beam.

FIGURE 6010.515 SHEET 1 OF 2

SUDAS	IOWADOT	REVISION
		New 04-21-20
FIGURE 6010.515	STANDARD ROAD PLAN	SW-515
REVISIONS: New.		SHEET 1 of 2
Paul D. Wigand SUDAS DIRECTOR		Scott Miller DESIGN METHODS ENGINEER
TRIPLE RECTANGULAR AREA INTAKE		

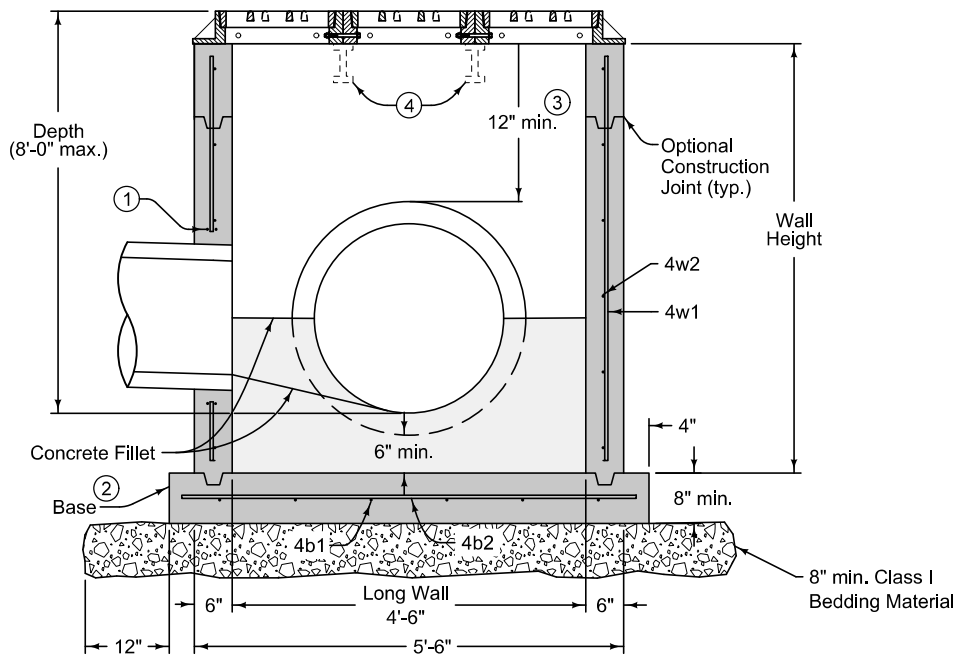

SECTION B-B

- ① Provide two #4 hoop bars at all pipe openings.
- ② Cast-in-place base shown. If base is precast integral with walls, the footprint of the base is not required to extend beyond the outer edge of the walls.
- ③ 12 inch minimum wall height above all pipes.
- ④ If required by casting manufacturer, provide support beam under all frame joints. Modify structure walls as required to provide pocket for beam.

REINFORCING BAR LIST						
Mark	Size	Location	Shape	Count	Length	Spacing
4b1	4	Base	—	6	3'-6"	12"
4b2	4	Base	—	4	5'-8"	12"
4w1	4	Walls	—	20	Wall Height minus 4"	12"
4w2	4	Short Wall	—	Varies	3'-0"	12"
4w3	4	Long Wall	—	Varies	5'-2"	12"

MAXIMUM PIPE DIAMETERS		
Pipe Location	Precast Structure	Cast-in-place Structure
Short Wall	18"	21"
Long Wall	36"	42"

SUDAS IOWADOT	REVISION	New	04-21-20
	FIGURE 6010.515	STANDARD ROAD PLAN	SW-515
REVISIONS: New.			SHEET 2 of 2
Paul D. Wigand SUDAS DIRECTOR		Steve Miller DESIGN METHODS ENGINEER	
TRIPLE RECTANGULAR AREA INTAKE			

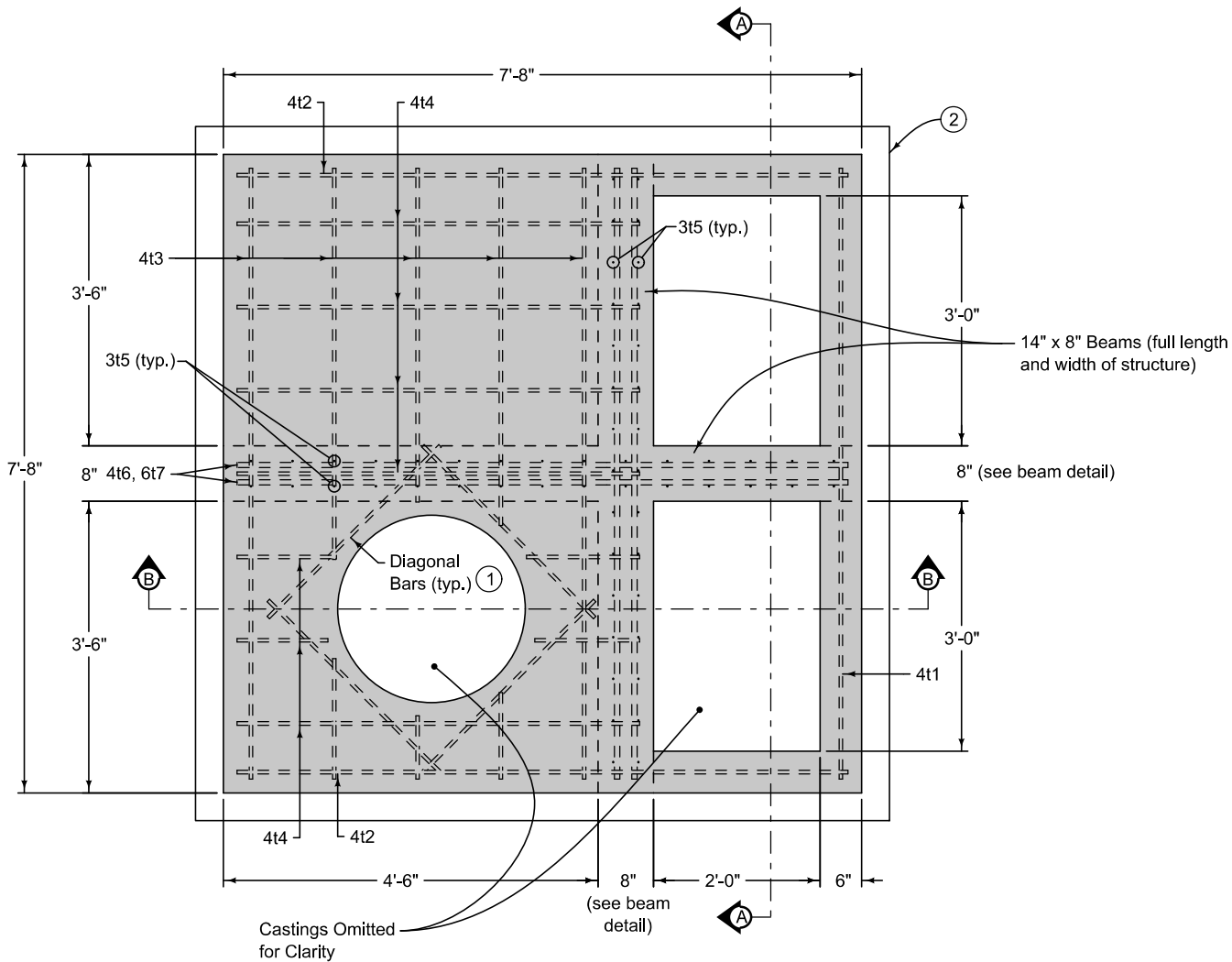

PLAN

Maximum pipe diameters are set based on maximum structure depth of 6 feet-6 inches.

Refer to SW-514 for boxout details.

- ① Install four #4 diagonal bars at manhole opening and at all pipe openings.
- ② Cast-in-place base shown. If base is precast integral with walls, the footprint of the base is not required to extend beyond the outer edge of the walls.

MAXIMUM PIPE DIAMETERS	
Wall	Max. Dia.
Front/Back	36"
Sides	42"

SUDAS	IOWADOT	REVISION
		New 4-16-24
FIGURE 6010.516	STANDARD ROAD PLAN	SW-516
		SHEET 1 of 3
REVISIONS: New		
 SUDAS DIRECTOR		 DESIGN METHODS ENGINEER
LARGE WELL DOUBLE GRATE INTAKE WITH MANHOLE		

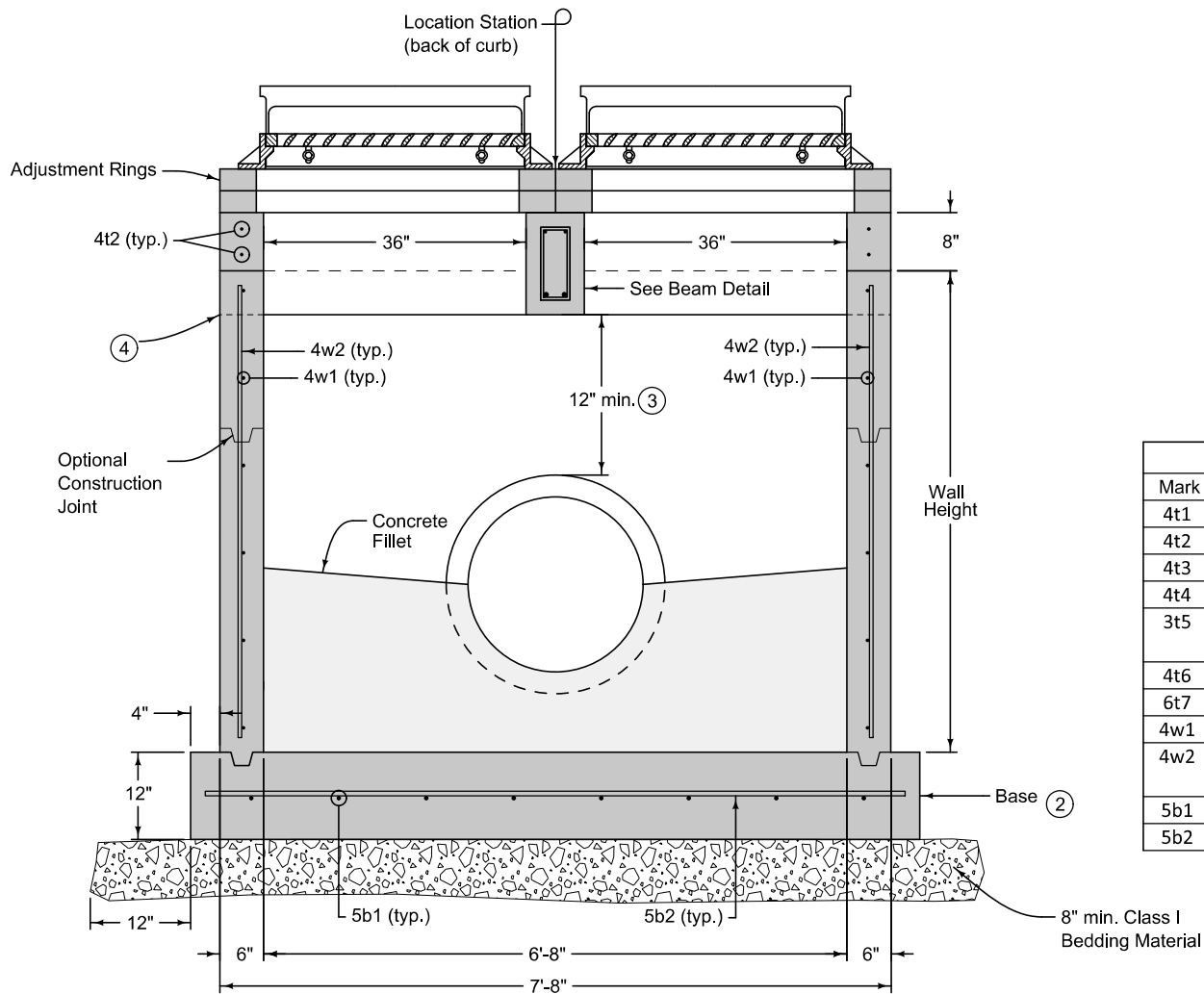

SECTION A-A

- ① Install four #4 diagonal bars at manhole opening and at all pipe openings.
- ② Cast-in-place base shown. If base is precast integral with walls, the footprint of the base is not required to extend beyond the outer edge of the walls.
- ③ 12 inch minimum wall height above all pipes.
- ④ Form pockets in the wall to receive integral beams in the top.

REINFORCING BAR LIST						
Mark	Size	Location	Shape	Count	Length	Spacing
4t1	4	Top	—	2	7'-4"	See Detail
4t2	4	Top	—	4	7'-4"	See Detail
4t3	4	Top	—	10	7'-4"	12"
4t4	4	Top	—	14	4'-2"	12"
3t5	3	Top	⊠	30	3'-1"	6"
4t6	4	Top	—	4	7'-4"	See Detail
6t7	6	Top	—	4	7'-4"	See Detail
4w1	4	Walls	—	Varies	7'-4"	12"
4w2	4	Walls	—	32	Wall Height minus 4"	12"
5b1	5	Base	—	9	7'-10"	12"
5b2	5	Base	—	9	7'-10"	12"

FIGURE 6010.516 SHEET 2 OF 3

SUDAS IOWADOT	REVISION	
	New	4-16-24
FIGURE 6010.516	STANDARD ROAD PLAN	SW-516
REVISIONS: New.		SHEET 2 of 3
SUDAS DIRECTOR		DESIGN METHODS ENGINEER
LARGE WELL DOUBLE GRATE INTAKE WITH MANHOLE		

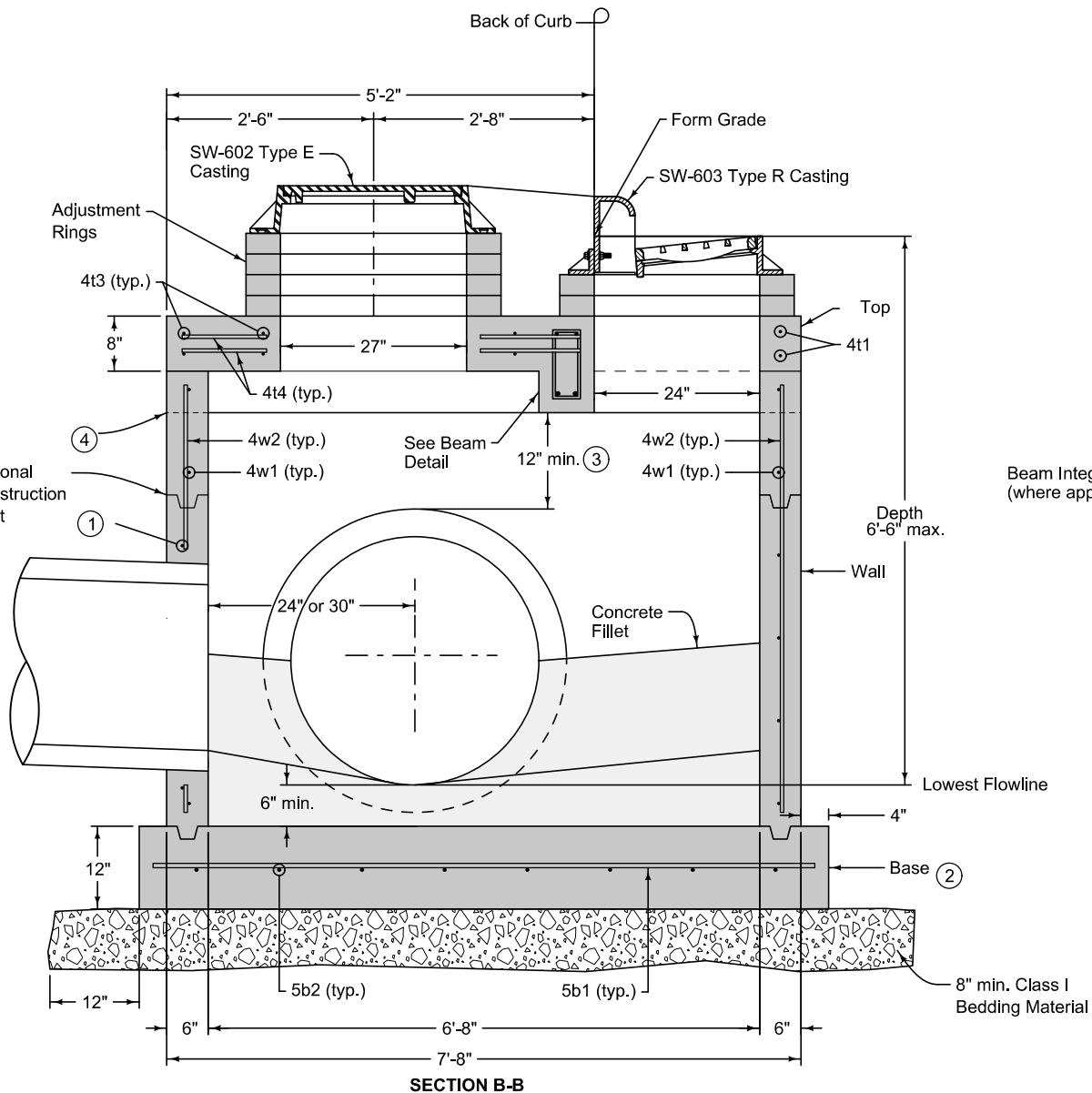

- ① Install four #4 diagonal bars at manhole opening and at all pipe openings.
- ② Cast-in-place base shown. If base is precast integral with walls, the footprint of the base is not required to extend beyond the outer edge of the walls.
- ③ 12 inch minimum wall height above all pipes.
- ④ Form pockets in the wall to receive integral beams in the top.

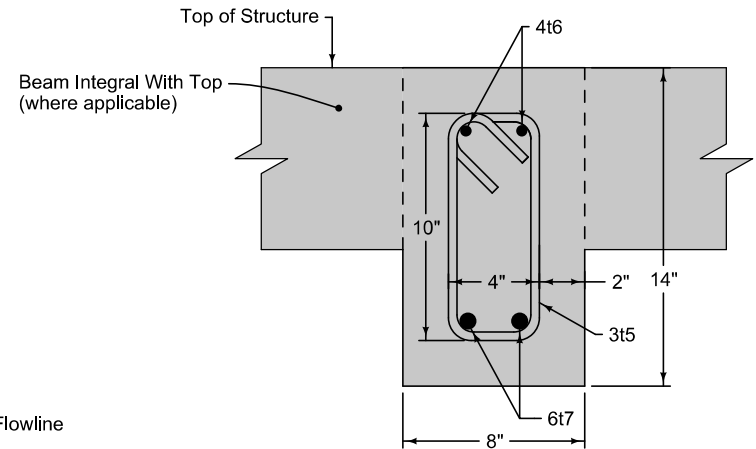

BEAM DETAIL

SUDAS	IOWADOT	REVISION
		New 4-16-24
FIGURE 6010.516	STANDARD ROAD PLAN	SW-516
REVISIONS: New.		SHEET 3 of 3

J.P.C.
 SUDAS DIRECTOR

Stuart Miller
 DESIGN METHODS ENGINEER

**LARGE WELL DOUBLE GRATE
INTAKE WITH MANHOLE**

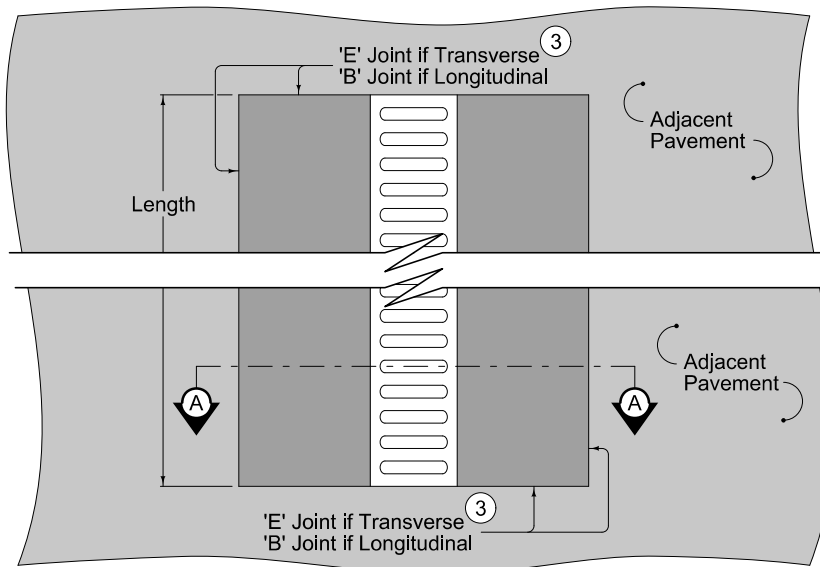

PLAN

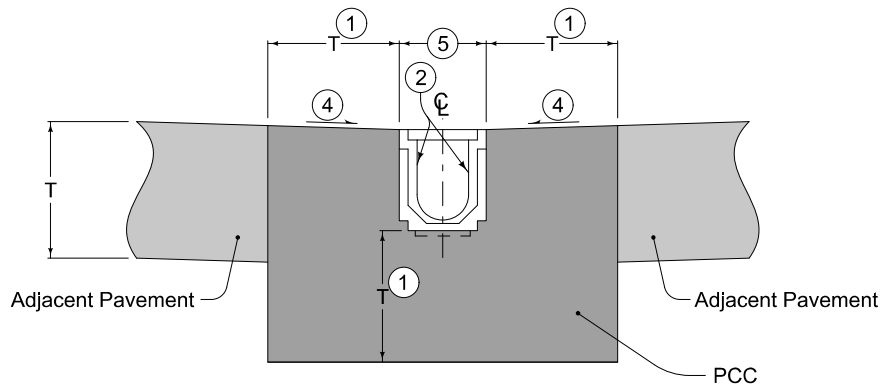

SECTION A-A

- ① 6 inches or same as thickness of adjacent pavement, whichever is greater.
- ② Linear Trench Drain.
- ③ For joint details, see PV-101.
- ④ Slope same as adjacent pavement.
- ⑤ Width as determined by manufacturer. Minimum 6 inches.

FIGURE 6010.521 SHEET 1 OF 2

SUDAS	IOWADOT	REVISION
		2 04-21-20
FIGURE 6010.521	STANDARD ROAD PLAN	SW-521
		SHEET 1 of 2
REVISIONS: Converted to joint standard. Modified circle note 1.		
Paul D. Wigand SUDAS DIRECTOR		Scott Miller DESIGN METHODS ENGINEER
LINEAR TRENCH DRAIN		

For joint details, refer to PV-101.

③ Additional keyed construction joint when attaching the SW-542 extension unit.

④ Top of well flush with pavement.

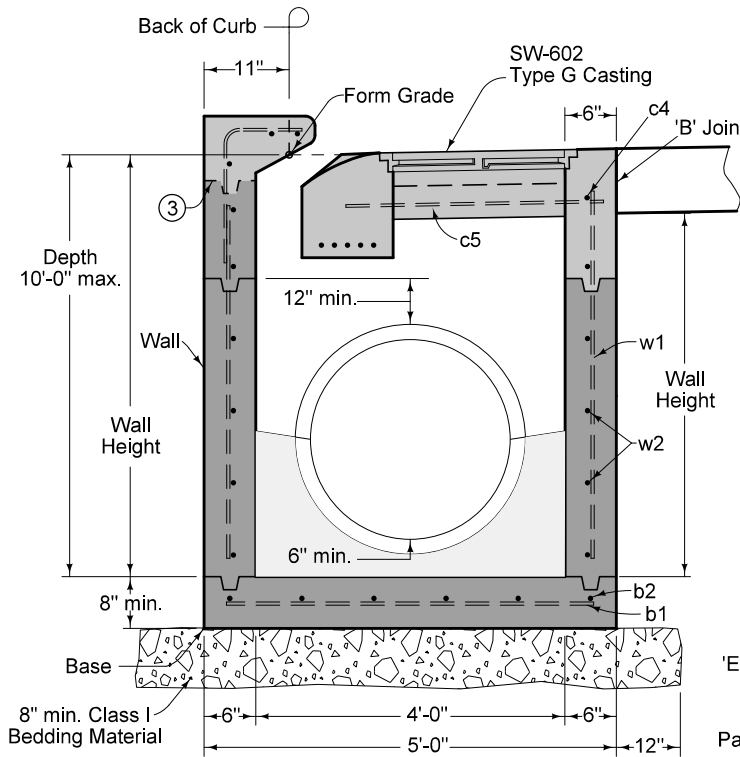

TYPICAL SECTION

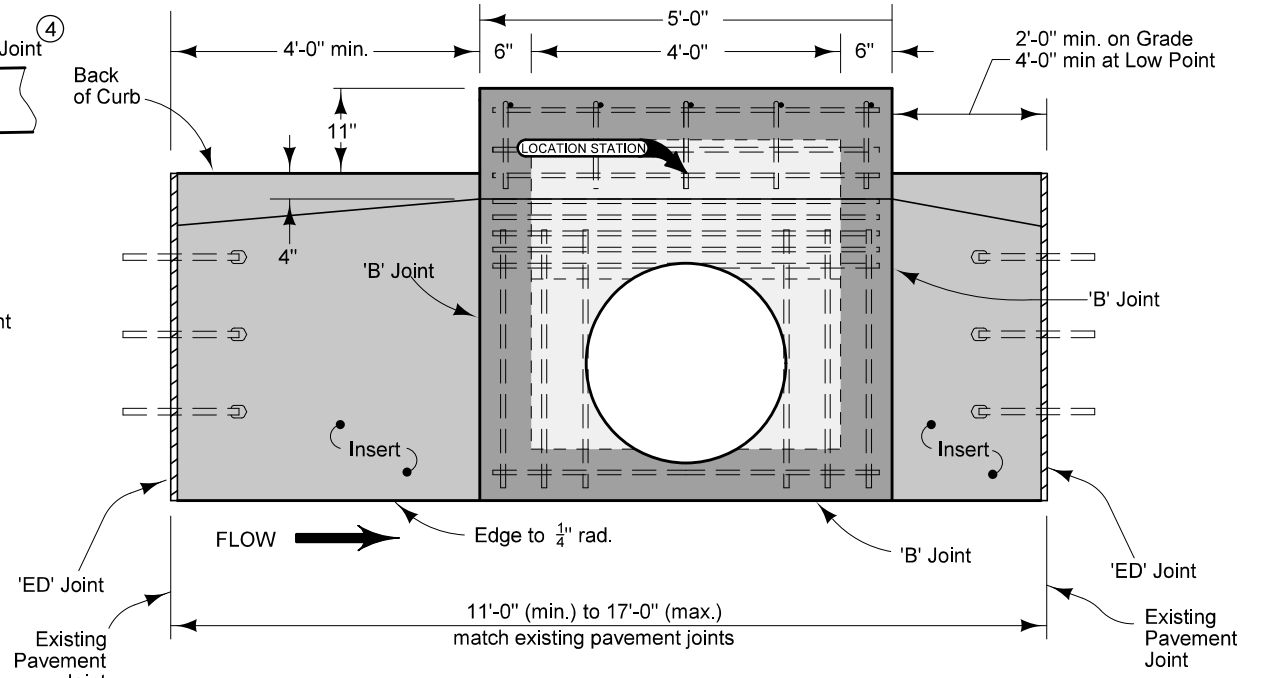

PLAN

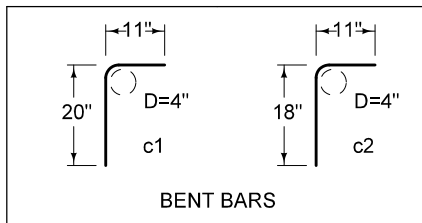

BENT BARS

REINFORCING BAR LIST					
Mark	Size	Location	Shape	Length	Spacing
b1	4	Base	—	4'-6"	11"
b2	4	Base	—	4'-6"	11"
w1	4	Wall	—	Wall Height minus 4"	14"
w2	4	Wall	—	4'-8"	12"
c1	4	Top	⌒	2'-7"	14"
c2	4	Top	⌒	2'-5"	14"
c3	4	Top	—	4'-8"	See Detail
c4	4	Top	—	4'-8"	See Detail
c5	4	Top	—	3'-2"	See Detail

MAXIMUM PIPE DIAMETER	
Precast	30"
Cast-in-Place	36"

		REVISION
		5 04-21-20
FIGURE 6010.541	STANDARD ROAD PLAN	SW-541
		SHEET 2 of 2
<small>REVISIONS: Changed well walls to 6 inch reinforced. Modified TYPICAL SECTION and c1 and c2 bar lengths. Added note 4. Added Class I bedding material.</small>		
<small>SUDAS DIRECTOR</small>		<small>DESIGN METHODS ENGINEER</small>
OPEN-THROAT CURB INTAKE UNDER PAVEMENT		

Extension unit may be used on either or both sides of SW-541 intakes. Details are similar when extension unit is on the opposite side.

- ① g3 for 6 inch standard curb; g5 for 4 inch sloped curb.
- ② c1 for 6 inch standard curb; c2 for 4 inch sloped curb. See SW-541 for reinforcing.
- ③ The location station is where the centerline of intake meets the back of the curb line.

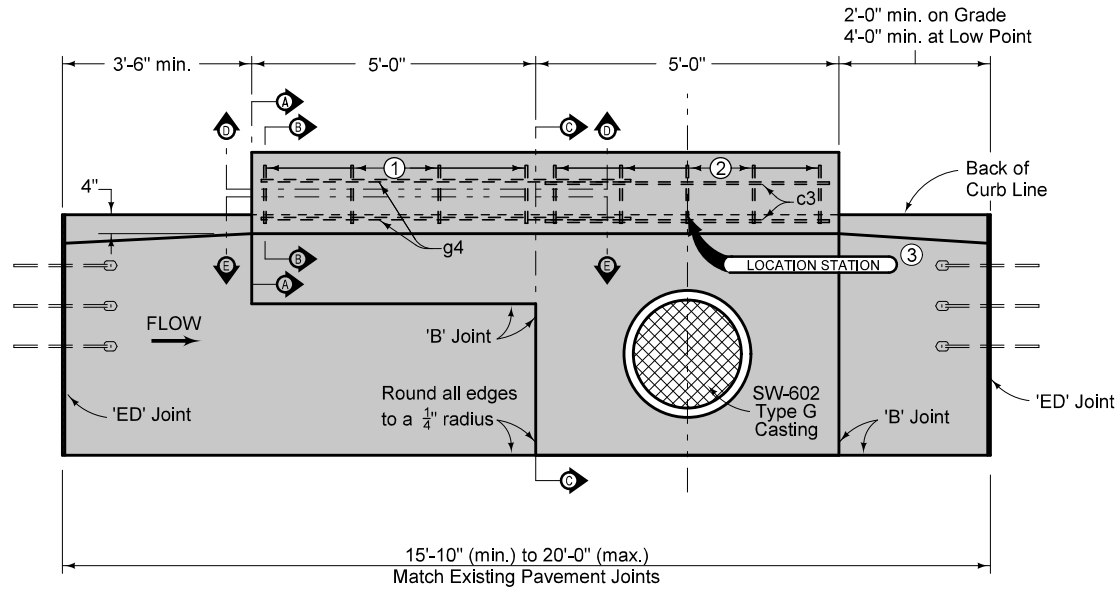

PLAN
(SW-542 EXTENSION AND SW-541 INTAKE)

Placing sequence: 1. Base; 2. Walls and Extension; 3. Top; 4. Insert

REINFORCING BAR LIST							
BAR	SIZE	LOCATION	SHAPE	NO.	LENGTH	WEIGHT	SPACING
b2	4	Intake Wall		3	2'-6"	5.0	9"
f1	4	Bottom		3	4'-9"	9.5	9"
f2	4	Bottom		4	1'-7"	4.2	18"
g1	4	Wall		5	Varies*	Varies*	12"
g2	4	Wall		1	4'-8"	3.1	-
g3	4	Top		4	Varies**	Varies**	18"
g4	4	Top		3	6'-4"	12.7	-
g5	4	Top		4	Varies**	Varies**	18"

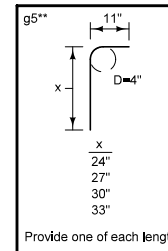
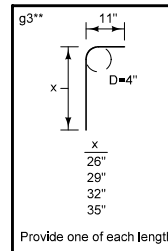
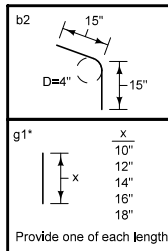
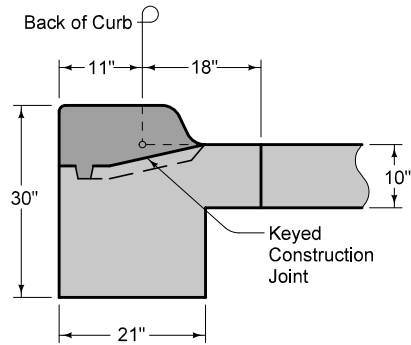
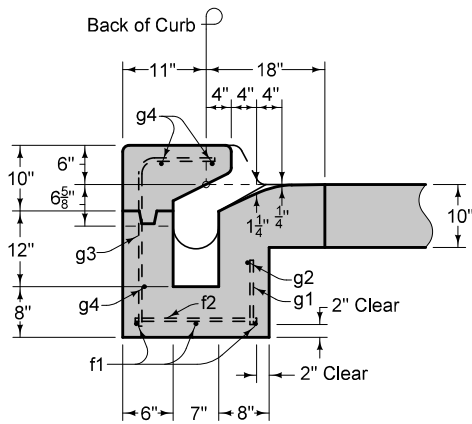

FIGURE 6010.542 SHEET 1 OF 4

	REVISION	5	10-20-20
	FIGURE 6010.542		STANDARD ROAD PLAN
SW-542		SHEET 1 of 4	
REVISIONS: Removed Interim from standard.			
 SUDAS DIRECTOR		 DESIGN METHODS ENGINEER	
EXTENSION UNIT FOR OPEN-THROAT CURB INTAKE UNDER PAVEMENT			



SECTION A-A



SECTION B-B

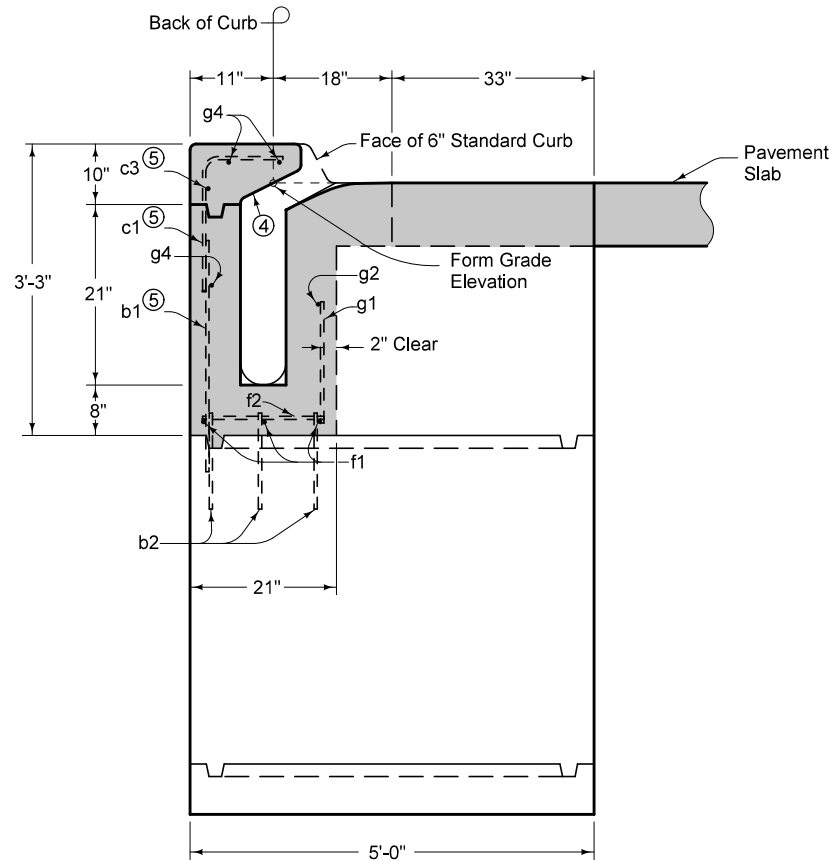

SECTION C-C

- ④ 2:1 Slope (Horizontal:Vertical)
- ⑤ See SW-541 for reinforcing.

6 INCH STANDARD CURB

	REVISION	5	10-20-20
	FIGURE 6010.542	STANDARD ROAD PLAN	SW-542
REVISIONS: Removed Interim from standard.			SHEET 2 of 4
 SUDAS DIRECTOR		 DESIGN METHODS ENGINEER	
EXTENSION UNIT FOR OPEN-THROAT CURB INTAKE UNDER PAVEMENT			

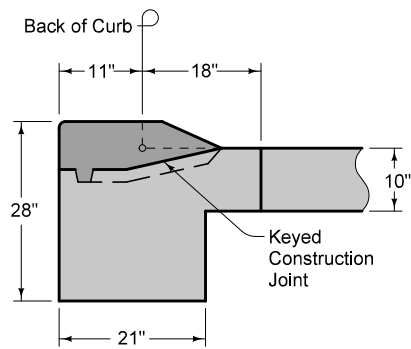

SECTION A-A

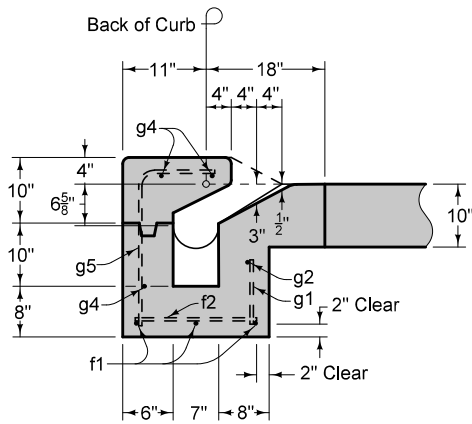

SECTION B-B

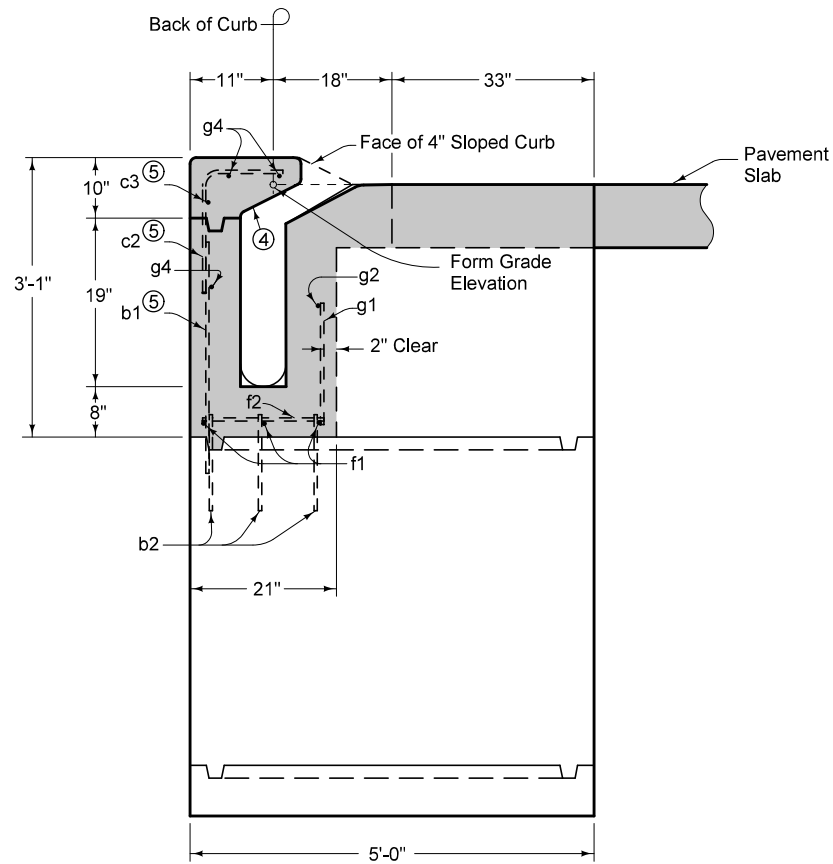

SECTION C-C

- ④ 2:1 Slope (Horizontal:Vertical)
- ⑤ See SW-541 for reinforcing.

4 INCH SLOPED CURB

FIGURE 6010.542 SHEET 3 OF 4

	REVISION	
	5	10-20-20
FIGURE 6010.542	STANDARD ROAD PLAN	SW-542
REVISIONS: Removed Interim from standard.		SHEET 3 of 4
 SUDAS DIRECTOR		 DESIGN METHODS ENGINEER
EXTENSION UNIT FOR OPEN-THROAT CURB INTAKE UNDER PAVEMENT		

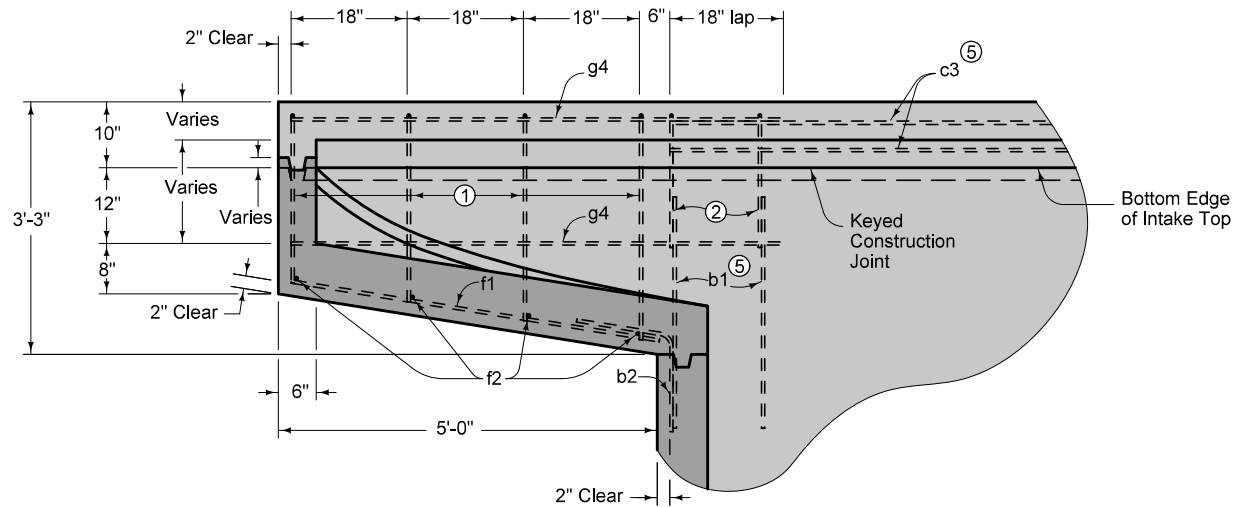

SECTION D-D

- ① g3 for 6 inch standard curb; g5 for 4 inch sloped curb.
- ② c1 for 6 inch standard curb; c2 for 4 inch sloped curb. See SW-541 for reinforcing.
- ⑤ See SW-541 for reinforcing.

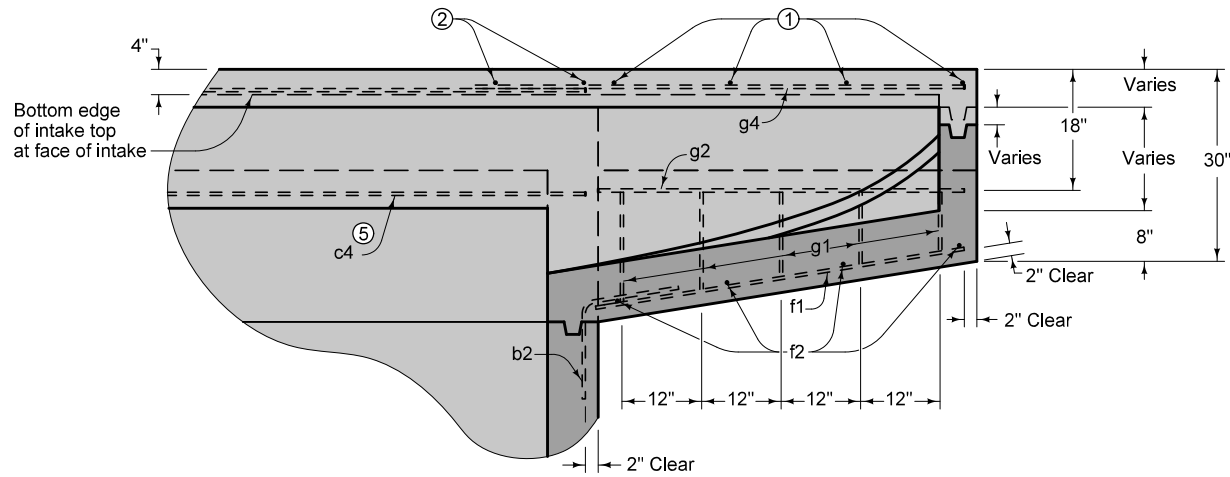

SECTION E-E

FIGURE 6010.542 SHEET 4 OF 4

	REVISION	5	10-20-20
	FIGURE 6010.542	STANDARD ROAD PLAN	SW-542
REVISIONS: Removed Interim from standard.			SHEET 4 of 4
 SUDAS DIRECTOR		 DESIGN METHODS ENGINEER	
EXTENSION UNIT FOR OPEN-THROAT CURB INTAKE UNDER PAVEMENT			

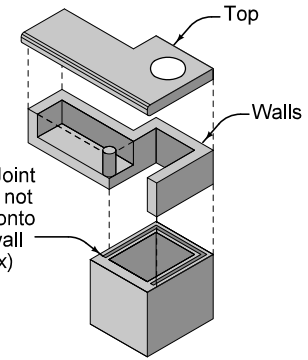
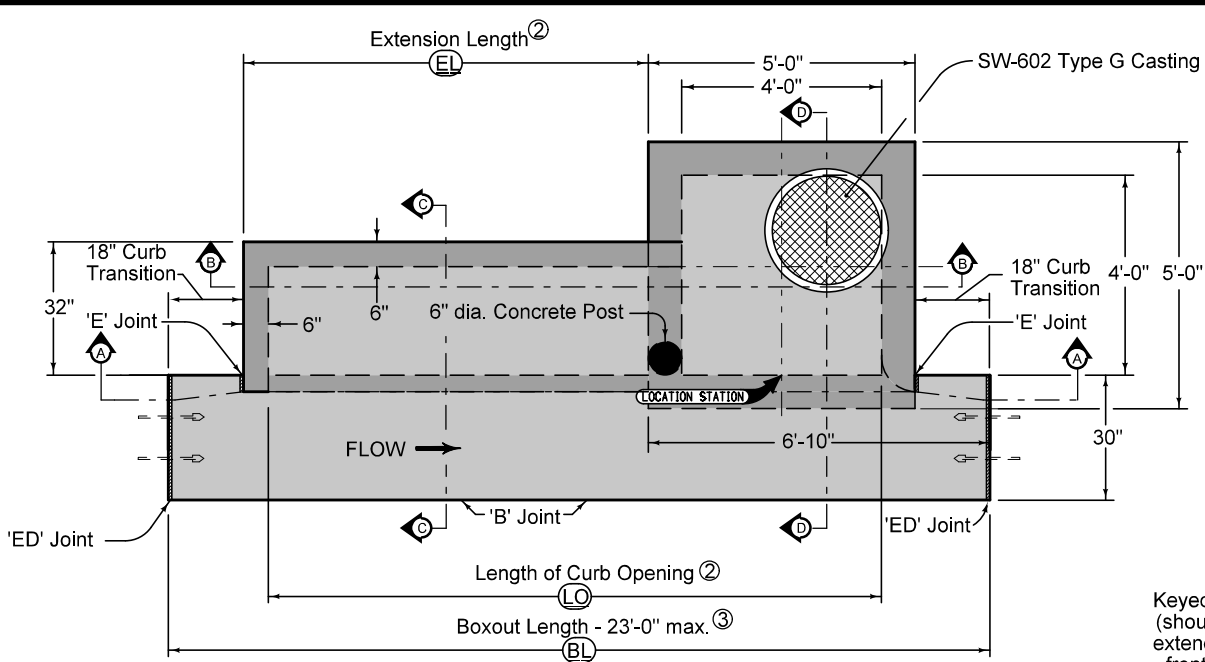

Extension unit may be used on either or both sides of intake. Details are similar when extension unit is on the opposite side. For joint details, refer to PV-101.

- ① Match gutter slope. Drain to well.
- ② Other lengths of opening may be constructed by varying the length of the extension and the rebar.
- ③ Includes 2 inches for 'ED' Joints.
- ④ 12 inch minimum wall height above all pipes.

MAXIMUM PIPE DIAMETERS	
Precast Structure	Cast-in-place Structure
30"	36"

ISOMETRIC INTAKE WELL, WALLS AND TOP

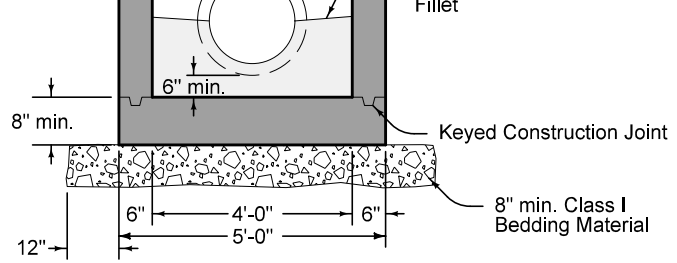
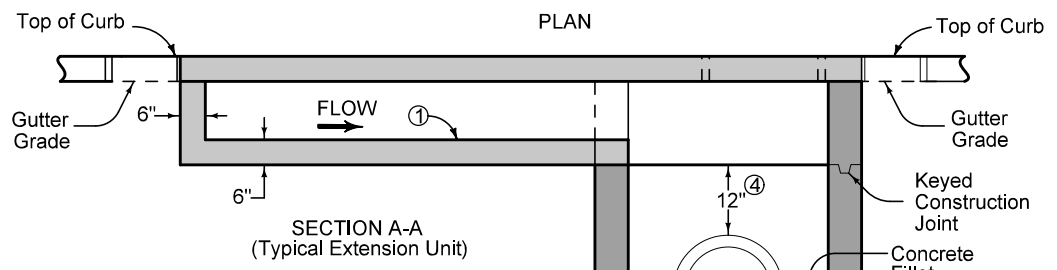
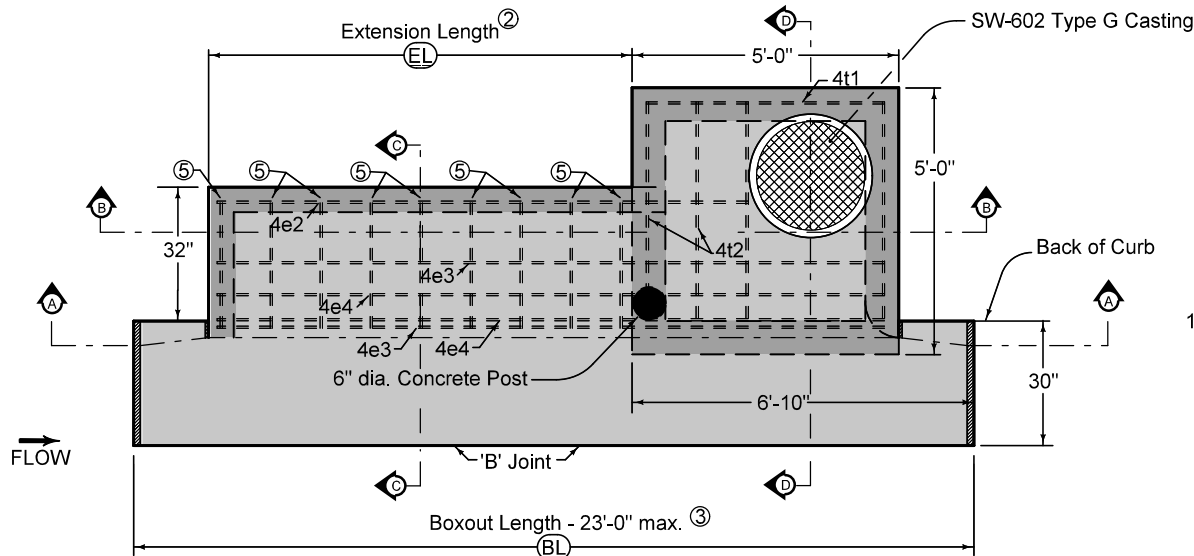

TABLE OF DIMENSIONS	
(LO) Length of Curb Opening	12'-0" 14'-0" 16'-0" 18'-0"
(EL) Extension Length	7'-10" 9'-10" 11'-10" 13'-10"
(BL) Minimum Boxout Length	16'-0" 18'-0" 20'-0" 22'-0"

FIGURE 6010.545 SHEET 10F 4

SUDAS	IOWADOT	REVISION
		6 04-19-22
FIGURE 6010.545	STANDARD ROAD PLAN	SW-545
REVISIONS: Clarified labeling of rebar.		SHEET 1 of 4
Paul D. Weigand SUDAS DIRECTOR		Stuart Miller DESIGN METHODS ENGINEER
SINGLE OPEN-THROAT CURB INTAKE WITH EXTENDED OPENING		



PLAN
TOP REINFORCING PLACEMENT

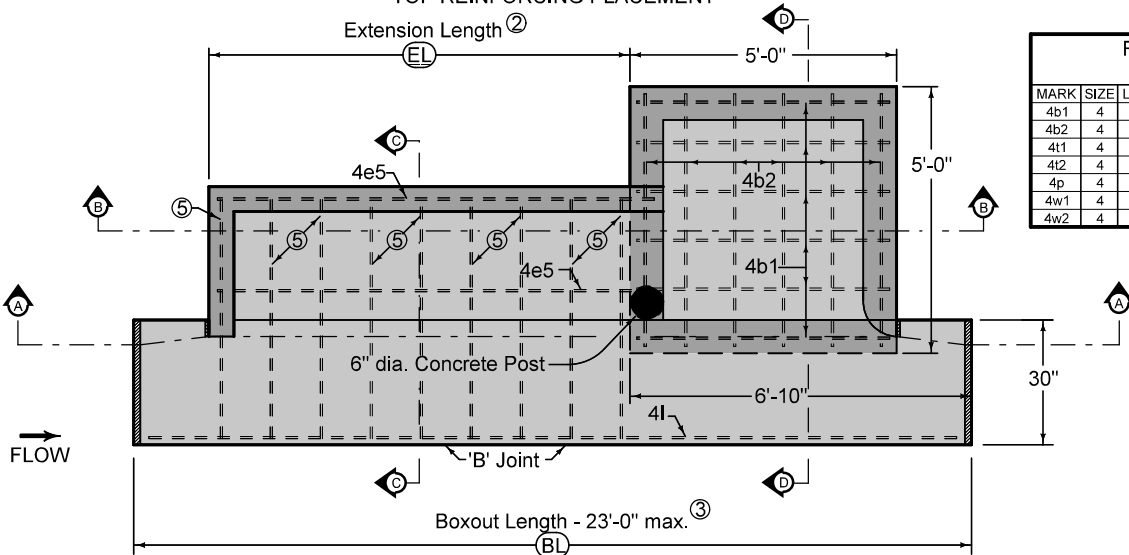

PLAN
BOTTOM REINFORCING PLACEMENT

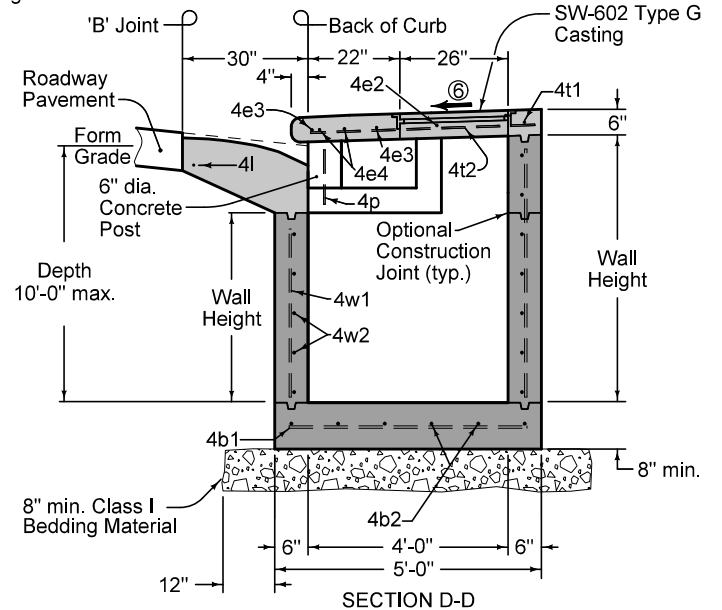

SECTION D-D

REINFORCING BAR LIST Intake Well					
MARK	SIZE	LOCATION	NO.	LENGTH	SPACING
4b1	4	Base	6	4'-6"	11"
4b2	4	Base	6	4'-6"	11"
4t1	4	Top	1	4'-8"	12"
4t2	4	Top	4	4'-3"	See Detail
4p	4	Post	1	13"	
4w1	4	Walls	16	Wall Height minus 4"	14"
4w2	4	Walls	Varies	4'-8"	12"

- ② Other lengths of opening may be constructed by varying the length of the extension and the rebar.
- ③ Includes 2 inches for 'ED' Joints.
- ⑤ 4e1 or 4e6. See Sheets 3 and 4.
- ⑥ Slope of 1.5% or as specified in the contract documents.

FIGURE 6010.545 SHEET 2 OF 4

SUDAS IOWADOT	REVISION 6 04-19-22
	SW-545 SHEET 2 of 4
REVISIONS: Clarified labeling of rebar.	
Paul D. Wiegand SUDAS DIRECTOR	
Stuart Miller DESIGN METHODS ENGINEER	
SINGLE OPEN-THROAT CURB INTAKE WITH EXTENDED OPENING	

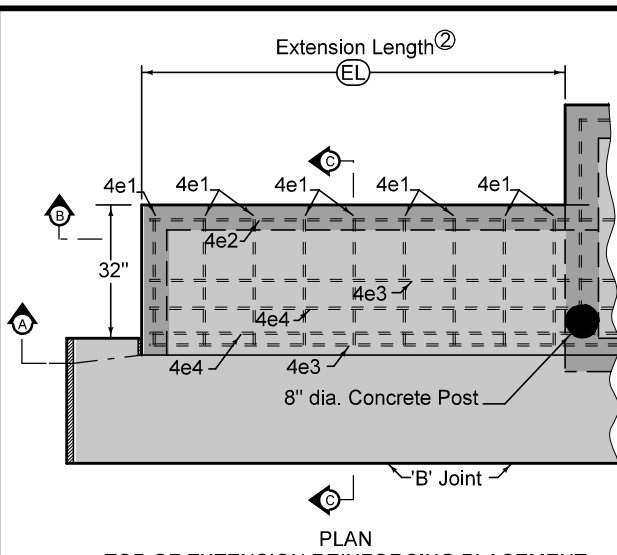

PLAN
TOP OF EXTENSION REINFORCING PLACEMENT

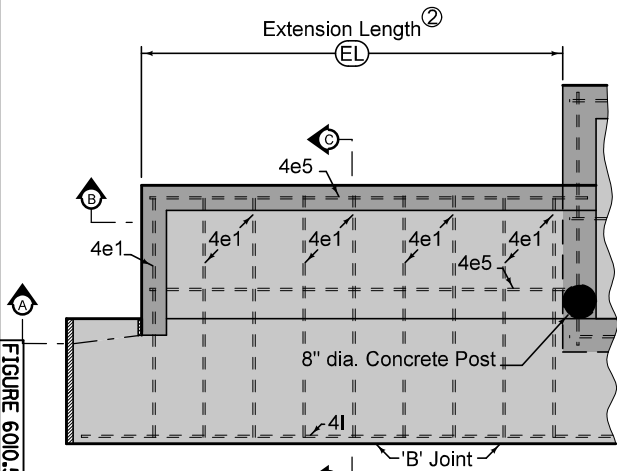

PLAN
BOTTOM OF EXTENSION REINFORCING PLACEMENT

FIGURE 6010.545 SHEET 3 OF 4

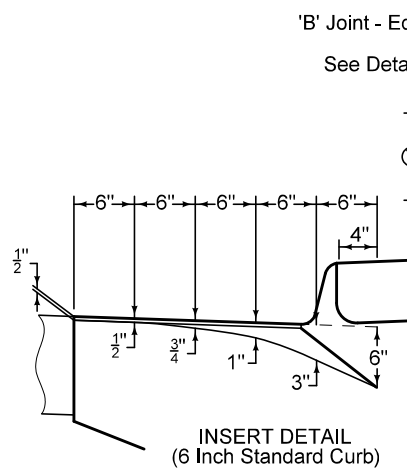

INSERT DETAIL
(6 Inch Standard Curb)

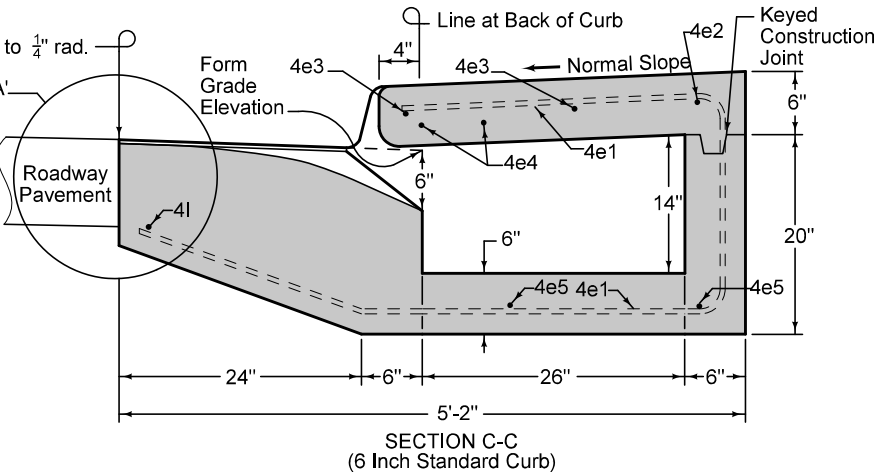

SECTION C-C
(6 Inch Standard Curb)

REINFORCING BAR LIST (LO = 12'-0")						
MARK	SIZE	LOCATION	NO.	LENGTH	WEIGHT	SPACING
4e1	4	Top/Base	9	9'-5 $\frac{1}{2}$ "	56.9	12"
4e2	4	Top	1	10'-0"	6.7	
4e3	4	Top	2	12'-9"	17.0	15 $\frac{1}{2}$ "
4e4	4	Top	2	12'-9"	17.0	6"
4e5	4	Base	2	8'-2"	10.9	22"
4I*	4	Insert	1	15'-10"	10.6	
				Total	119.1 lbs.	

* With 16'-6" Boxout.

REINFORCING BAR LIST (LO = 14'-0")						
MARK	SIZE	LOCATION	NO.	LENGTH	WEIGHT	SPACING
4e1	4	Top/Base	11	9'-5 $\frac{1}{2}$ "	69.5	12"
4e2	4	Top	1	12'-0"	8.0	
4e3	4	Top	2	14'-9"	19.7	15 $\frac{1}{2}$ "
4e4	4	Top	2	14'-9"	19.7	6"
4e5	4	Base	2	10'-2"	13.6	22"
4I*	4	Insert	1	17'-10"	11.9	
				Total	142.4 lbs.	

* With 18'-6" Boxout.

REINFORCING BAR LIST (LO = 16'-0")						
MARK	SIZE	LOCATION	NO.	LENGTH	WEIGHT	SPACING
4e1	4	Top/Base	13	9'-5 $\frac{1}{2}$ "	82.1	12"
4e2	4	Top	1	14'-0"	9.3	
4e3	4	Top	2	16'-9"	22.4	15 $\frac{1}{2}$ "
4e4	4	Top	2	16'-9"	22.4	6"
4e5	4	Base	2	12'-2"	16.2	22"
4I*	4	Insert	1	19'-10"	13.2	
				Total	165.6 lbs.	

* With 20'-6" Boxout.

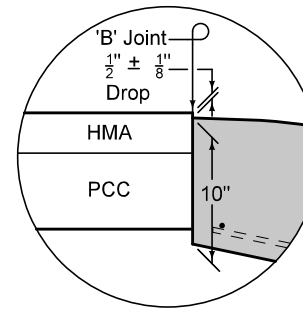

DETAIL 'A'
Use when adjacent pavement
is HMA or composite.

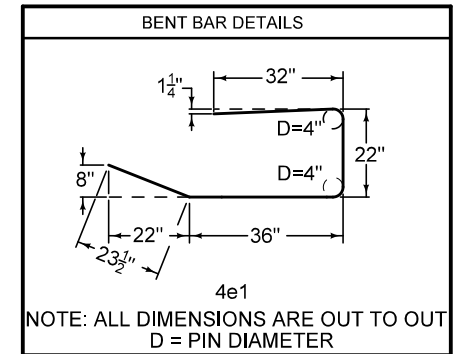

NOTE: ALL DIMENSIONS ARE OUT TO OUT
D = PIN DIAMETER

② Other lengths of opening may be constructed by varying the length of the extension and the rebar.

REINFORCING BAR LIST (LO = 18'-0")						
MARK	SIZE	LOCATION	NO.	LENGTH	WEIGHT	SPACING
4e1	4	Top/Base	15	9'-5 $\frac{1}{2}$ "	94.8	12"
4e2	4	Top	1	16'-0"	10.7	
4e3	4	Top	2	18'-9"	25	15 $\frac{1}{2}$ "
4e4	4	Top	2	18'-9"	25	6"
4e5	4	Base	2	14'-2"	18.9	22"
4I*	4	Insert	1	21'-10"	14.6	
				Total	189.0 lbs.	

* With 22'-6" Boxout.

SUDAS IOWADOT FIGURE 6010.545 STANDARD ROAD PLAN	REVISION 6 04-19-22
	SW-545 SHEET 3 of 4

REVISIONS: Clarified labeling of rebar.

Paul D. Wigand
SUDAS DIRECTOR

Scott Miller
DESIGN METHODS ENGINEER

**SINGLE OPEN-THROAT
CURB INTAKE WITH
EXTENDED OPENING**

6 INCH STANDARD CURB

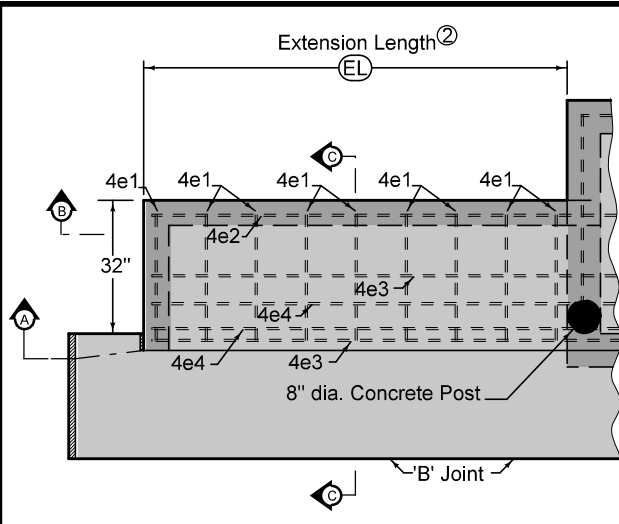

PLAN
TOP OF EXTENSION REINFORCING PLACEMENT

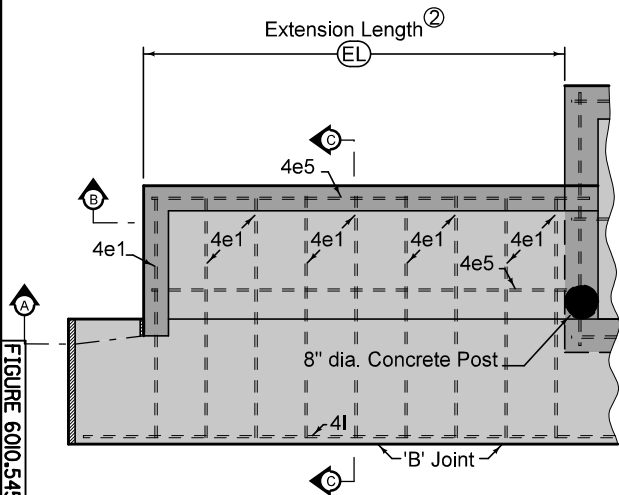

PLAN
BOTTOM OF EXTENSION REINFORCING PLACEMENT

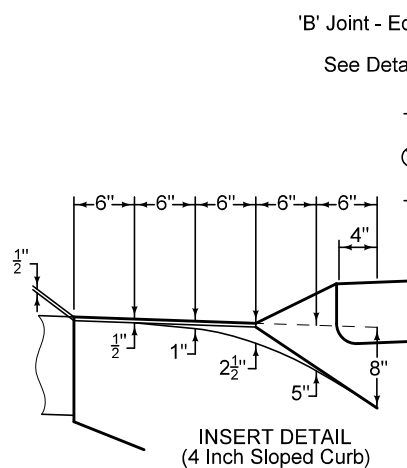

INSERT DETAIL
(4 Inch Sloped Curb)

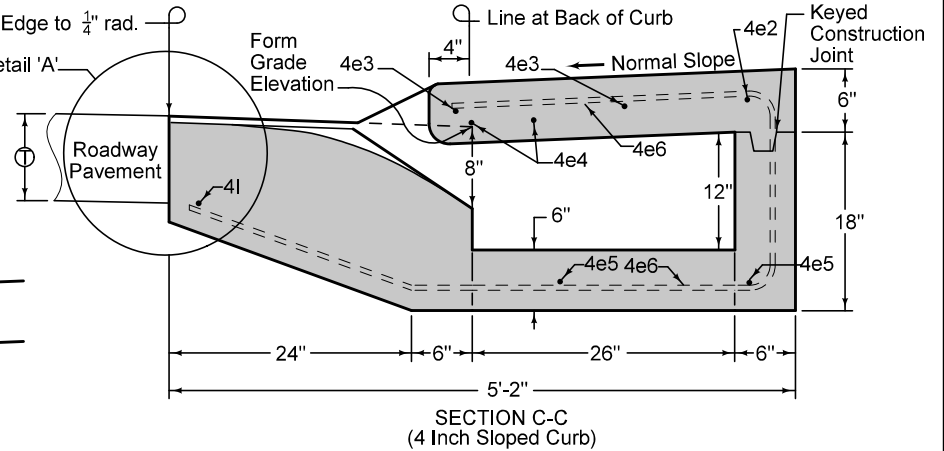

SECTION C-C
(4 Inch Sloped Curb)

REINFORCING BAR LIST (O) = 12'-0"						
MARK	SIZE	LOCATION	NO.	LENGTH	WEIGHT	SPACING
4e2	4	Top	1	10'-0"	6.7	
4e3	4	Top	2	12'-9"	17.0	15 $\frac{1}{2}$ "
4e4	4	Top	2	12'-9"	17.0	6"
4e5	4	Base	2	8'-2"	10.9	22"
4e6	4	Top/Base	9	9'-3 $\frac{3}{4}$ "	56.9	12"
4I*	4	Insert	1	15'-10"	10.6	
				* With 16'-6" Boxout.	Total	119.0 lbs.

REINFORCING BAR LIST (O) = 14'-0"						
MARK	SIZE	LOCATION	NO.	LENGTH	WEIGHT	SPACING
4e2	4	Top	1	12'-0"	8.0	
4e3	4	Top	2	14'-9"	19.7	15 $\frac{1}{2}$ "
4e4	4	Top	2	14'-9"	19.7	6"
4e5	4	Base	2	10'-2"	13.6	22"
4e6	4	Top/Base	11	9'-3 $\frac{3}{4}$ "	69.5	12"
4I*	4	Insert	1	17'-10"	11.9	
				* With 18'-6" Boxout.	Total	142.3 lbs.

REINFORCING BAR LIST (O) = 16'-0"						
MARK	SIZE	LOCATION	NO.	LENGTH	WEIGHT	SPACING
4e2	4	Top	1	14'-0"	9.3	
4e3	4	Top	2	16'-9"	22.4	15 $\frac{1}{2}$ "
4e4	4	Top	2	16'-9"	22.4	6"
4e5	4	Base	2	12'-2"	16.2	22"
4e6	4	Top/Base	13	9'-3 $\frac{3}{4}$ "	82.1	12"
4I*	4	Insert	1	19'-10"	13.2	
				* With 20'-6" Boxout.	Total	165.5 lbs.

REINFORCING BAR LIST (O) = 18'-0"						
MARK	SIZE	LOCATION	NO.	LENGTH	WEIGHT	SPACING
4e2	4	Top	1	16'-0"	10.7	
4e3	4	Top	2	18'-9"	25	15 $\frac{1}{2}$ "
4e4	4	Top	2	18'-9"	25	6"
4e5	4	Base	2	14'-2"	18.9	22"
4e6	4	Top/Base	15	9'-3 $\frac{3}{4}$ "	94.8	12"
4I*	4	Insert	1	21'-10"	14.6	
				* With 22'-6" Boxout.	Total	188.9 lbs.

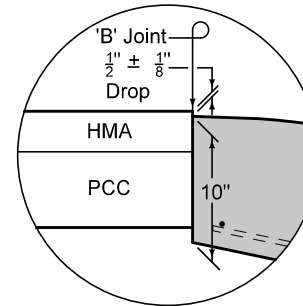

DETAIL 'A'
Use when adjacent pavement
is HMA or composite.

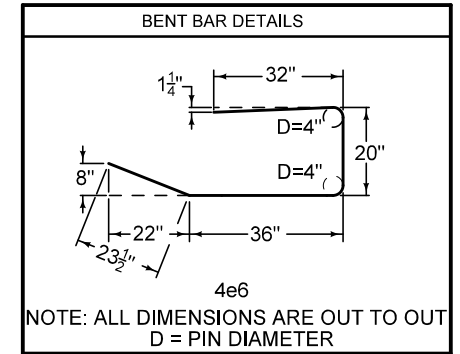

NOTE: ALL DIMENSIONS ARE OUT TO OUT
D = PIN DIAMETER

② Other lengths of opening may be constructed by varying the length of the extension and the rebar.

FIGURE 6010.545 SHEET 4 OF 4

4 INCH SLOPED CURB

SUDAS IOWADOT FIGURE 6010.545 STANDARD ROAD PLAN	REVISION 6 04-19-22
	SW-545 SHEET 4 of 4
REVISIONS: Clarified labeling of rebar.	
Paul D. Wigand SUDAS DIRECTOR	
Steve Miller DESIGN METHODS ENGINEER	
SINGLE OPEN-THROAT CURB INTAKE WITH EXTENDED OPENING	

TYPE A
Two-piece fixed casting

TYPE C
Two-piece fixed casting with bolt-down cover (2)

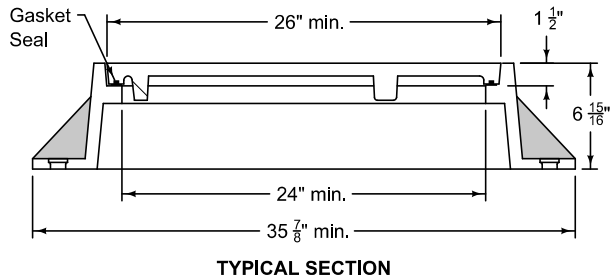
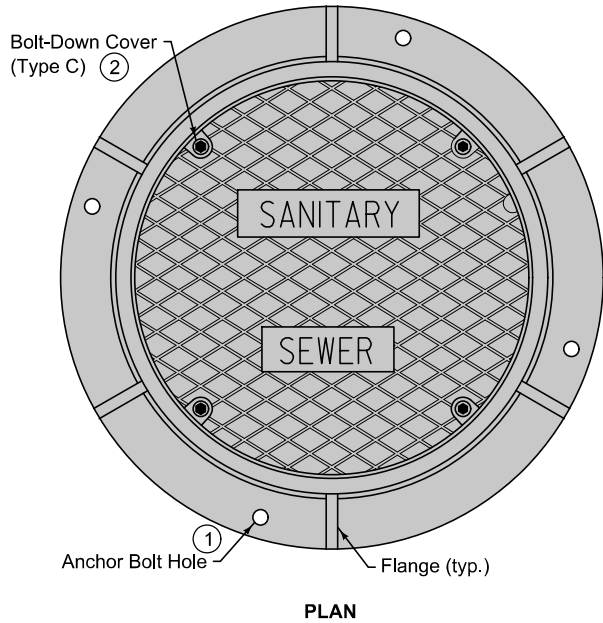

TYPE B: HMA
Three-piece floating casting for use in HMA paving

TYPE D: HMA
Three-piece floating casting with bolt-down cover for use in HMA paving (2)

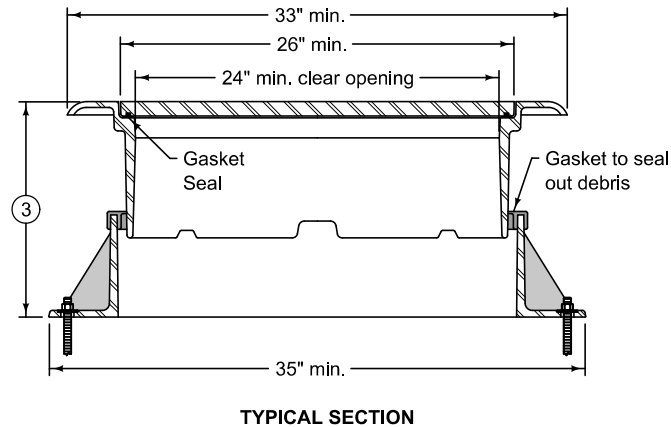
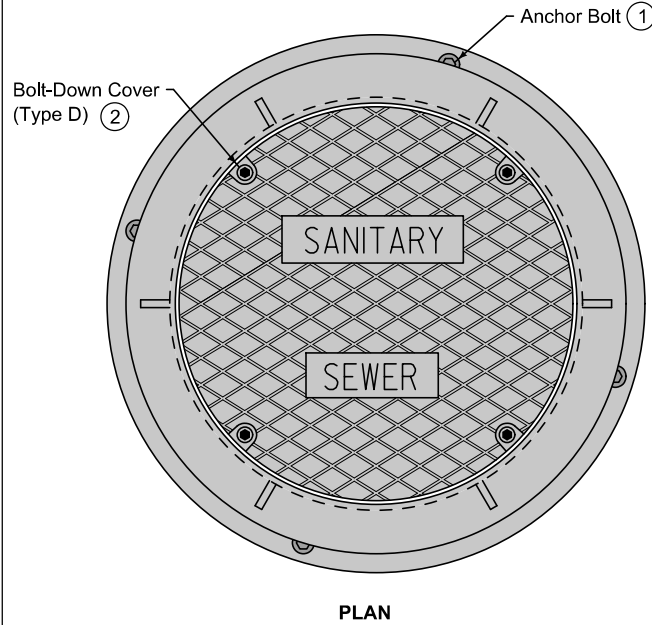

Frame Notes:
Size, spacing, and number of lugs and flanges may vary.

Cover Notes:
Roughness pattern and text style may vary.
Minimum one concealed pickhole.

- ① Anchor the lower frame of all three-piece castings to the manhole structure. When specified in the contract documents, anchor the frame of two-piece castings to the manhole structure. If casting frame does not include anchor holes or slots, drill four 7/8 inch diameter holes, equally spaced around the frame.
- ② If specified, furnish bolt down frame and cover with four 1/2 inch minimum diameter stainless steel, hex nut, recessed cap screws. Secure cover with screws, washers, and rubber gasket seals.
- ③ Casting height varies. Minimum adjustment range of 4 inches.

FIGURE 6010.601 SHEET 1 OF 2

SUDAS	IOWADOT	REVISION
		4 04-21-20
FIGURE 6010.601	STANDARD ROAD PLAN	SW-601
		SHEET 1 of 2
REVISIONS: Add option for 3-piece HMA casting		
Paul D. Wigand SUDAS DIRECTOR		Shawn Miller DESIGN METHODS ENGINEER
CASTINGS FOR SANITARY SEWER MANHOLES		

TYPE B: PCC

Three-piece floating casting for use in PCC paving and PCC boxouts

TYPE D: PCC

Three-piece floating casting with bolt-down cover for use in PCC paving and PCC boxouts

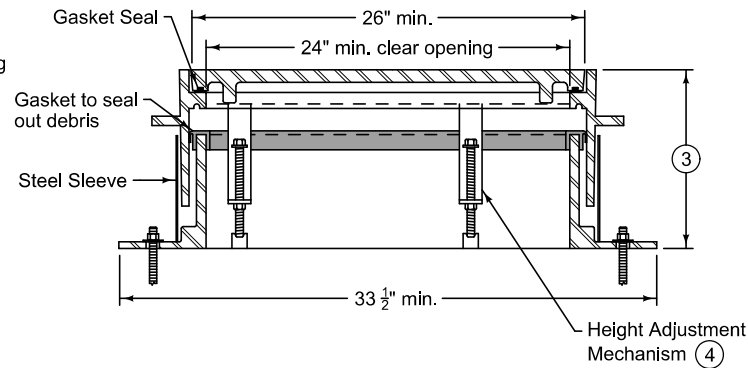
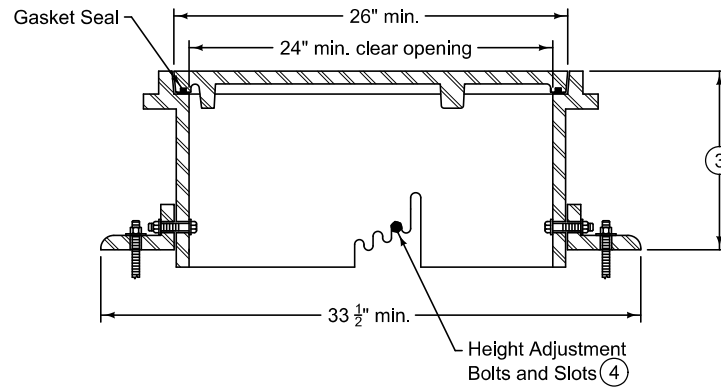
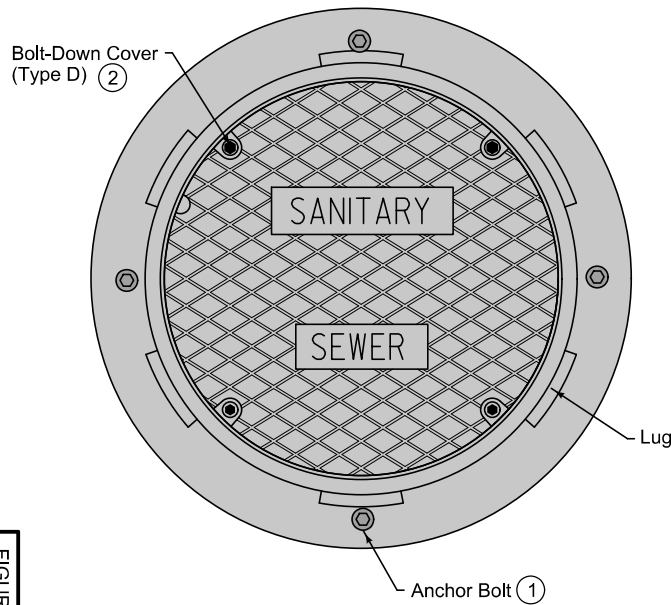

TYPICAL SECTION (5)

Frame Notes:
Size, spacing, and number of lugs and flanges may vary.

Cover Notes:
Roughness pattern and text style may vary.
Minimum one concealed pickhole.

- ① Anchor the lower frame of all three-piece castings to the manhole structure. When specified in the contract documents, anchor the frame of two-piece castings to the manhole structure. If casting frame does not include anchor holes or slots, drill four 7/8 inch diameter holes, equally spaced around the frame.
- ② If specified, furnish bolt down frame and cover with four 1/2 inch minimum diameter stainless steel, hex nut, recessed cap screws. Secure cover with screws, washers, and rubber gasket seals.
- ③ Casting height varies. Minimum adjustment range of 4 inches.
- ④ Set casting at proper grade using the adjustment slots or adjustment mechanism. Remove bolts or mechanism upon completion of paving.
- ⑤ Height adjustment method may vary; two options are shown.

SUDAS	IOWADOT	REVISION	
		4	04-21-20
FIGURE 6010.601	STANDARD ROAD PLAN	SW-601	
		SHEET 2 of 2	

REVISIONS: Add option for 3-piece HMA casting

Paul D. Wigand
SUDAS DIRECTOR

Stuart Nadeau
DESIGN METHODS ENGINEER

**CASTINGS FOR
SANITARY SEWER MANHOLES**

TYPE E
Two-piece fixed casting

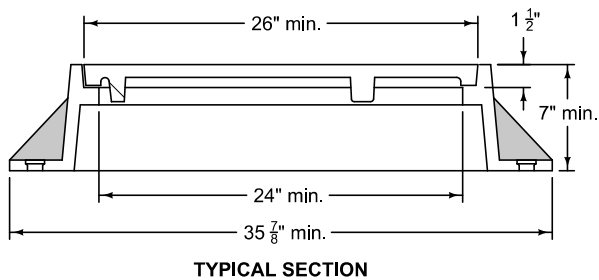
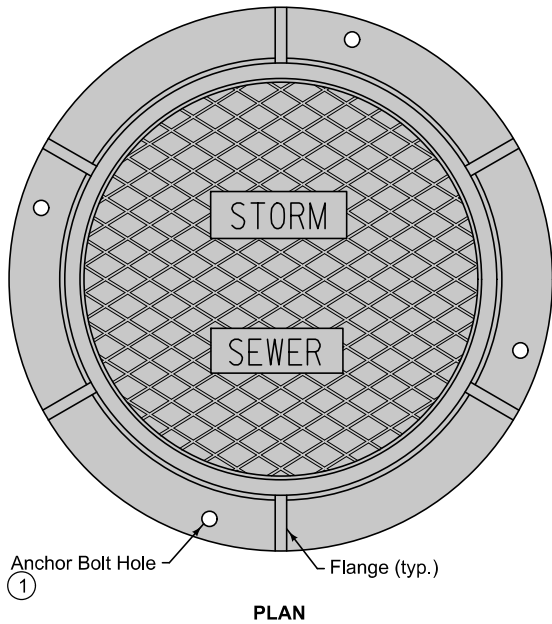

TYPE F: HMA
Three-piece floating casting for use in HMA paving

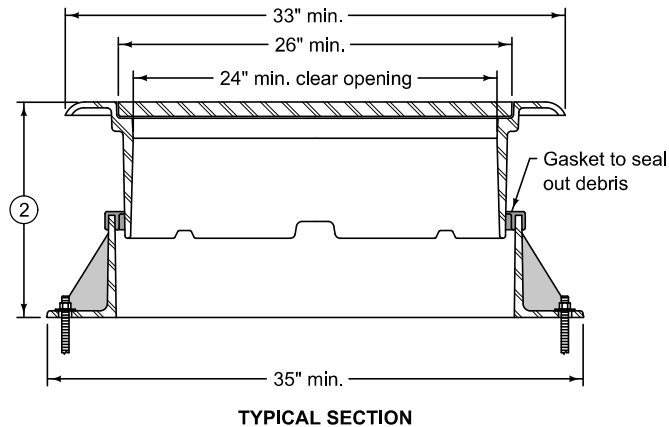
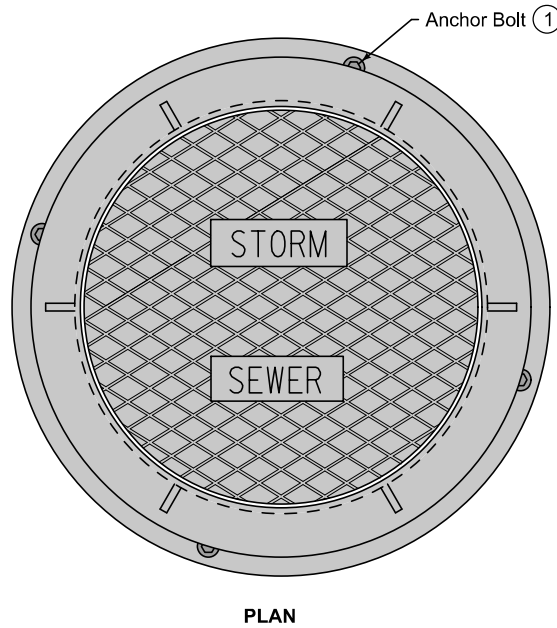

Frame Notes:
Size, spacing, and number of lugs and flanges may vary.

Cover Notes:
Roughness pattern and text style may vary.
Minimum one pickhole.

- ① Anchor the lower frame of all three-piece castings to the manhole structure. When specified in the contract documents, anchor the frame of two-piece castings to the manhole structure. If casting frame does not include anchor holes or slots, drill four 7/8 inch diameter holes, equally spaced around the frame.
- ② Casting height varies. Minimum adjustment range of 4 inches.

		REVISION
		4 04-21-20
FIGURE 6010.602	STANDARD ROAD PLAN	SW-602
REVISIONS: Add option for 3-piece HMA casting		SHEET 1 of 3
 SUDAS DIRECTOR		 DESIGN METHODS ENGINEER
CASTINGS FOR STORM SEWER MANHOLES		

TYPE F: PCC

Three-piece floating casting for use in PCC paving and PCC boxouts

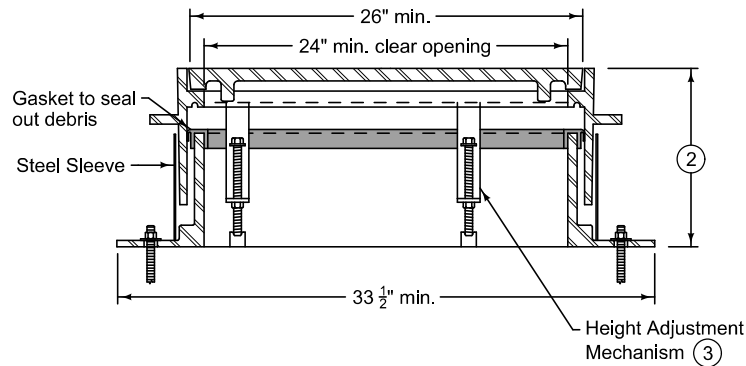
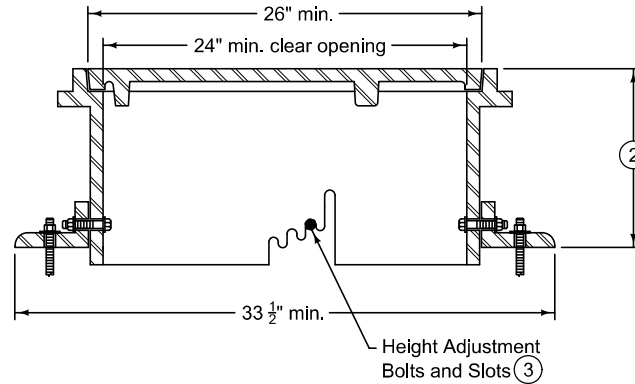
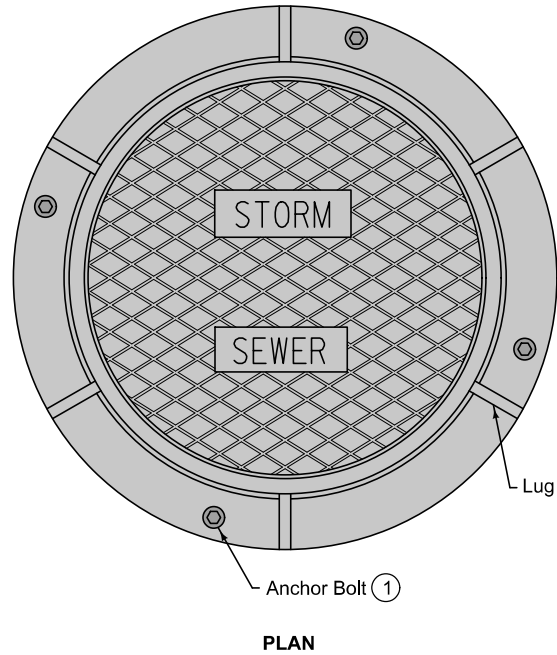

TYPICAL SECTION ④

Frame Notes:
Size, spacing, and number of lugs and flanges may vary.

Cover Notes:
Roughness pattern and text style may vary.
Minimum one pickhole.

- ① Anchor the lower frame of all three-piece castings to the manhole structure. When specified in the contract documents, anchor the frame of two-piece castings to the manhole structure. If casting frame does not include anchor holes or slots, drill four 7/8 inch diameter holes, equally spaced around the frame.
- ② Casting height varies. Minimum adjustment range of 4 inches.
- ③ Set casting at proper grade using the adjustment slots or adjustment mechanism. Remove bolts or mechanism upon completion of paving.
- ④ Height adjustment method may vary; two options are shown.

FIGURE 6010.602 SHEET 2 OF 3

SUDAS	IOWADOT	REVISION
		4 04-21-20
FIGURE 6010.602	STANDARD ROAD PLAN	SW-602
		SHEET 2 of 3
REVISIONS: Add option for 3-piece HMA casing		
Paul D. Wigand SUDAS DIRECTOR		Shawn Miller DESIGN METHODS ENGINEER
CASTINGS FOR STORM SEWER MANHOLES		

TYPE G
Two piece fixed casting

Cover Notes:
Roughness pattern and text style may vary.
Minimum one pickhole.

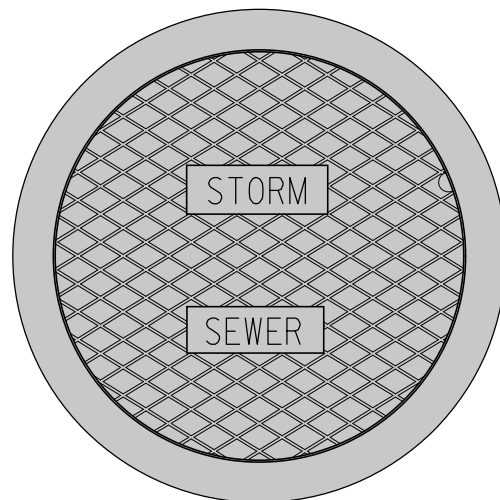

PLAN

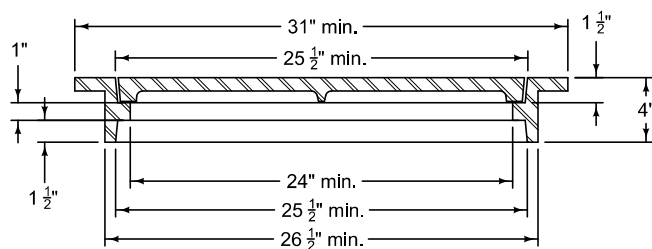

TYPICAL SECTION

FIGURE 6010.602 SHEET 3 OF 3

SUDAS	IOWADOT	REVISION
		4 04-21-20
FIGURE 6010.602	STANDARD ROAD PLAN	SW-602
		SHEET 3 of 3

REVISIONS: Add option for 3-piece HMA casting

Paul D. Wigand
 SUDAS DIRECTOR

Stuart M. Nelson
 DESIGN METHODS ENGINEER

**CASTINGS FOR
STORM SEWER MANHOLES**

TYPE Q ^①
 Driveway Gate
 (Minimum open area 370 in²)

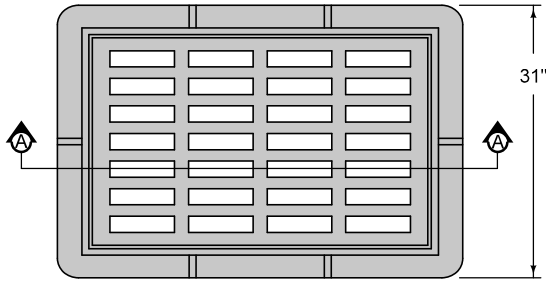

PLAN

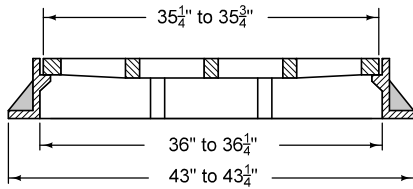

SECTION A-A

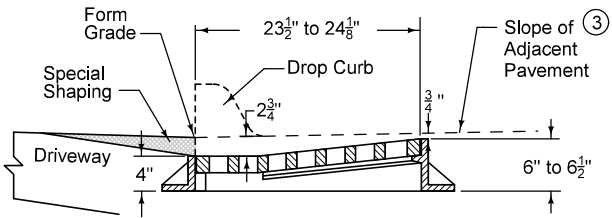

TYPICAL SECTION

TYPE R ^②
 Curb Inlet Gate
 (Minimum open area 180 in²)

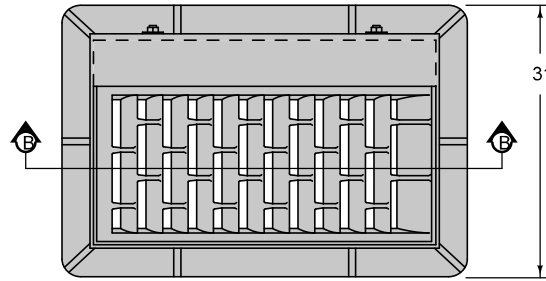

PLAN

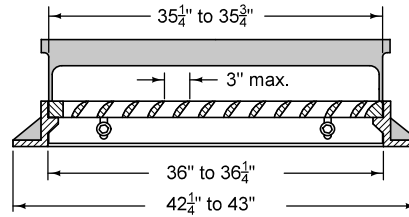

SECTION B-B

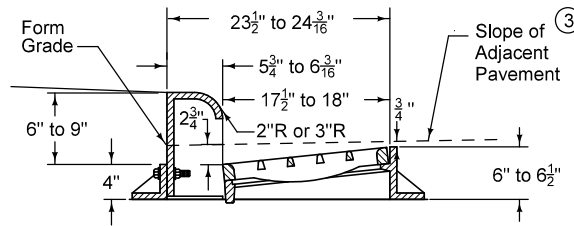

TYPICAL SECTION

- ① For use at curb drops for driveways. Use only when specified in the contract documents.
- ② Provide bicycle-safe vane-style grate. At low points, grates with vanes facing both directions of flow are allowed.
- ③ For details of boxout pavement, refer to SW-514.

FIGURE 6010.603 SHEET 1 OF 2

SUDAS IOWADOT	REVISION
	6 10-16-18
FIGURE 6010.603	STANDARD ROAD PLAN
SW-603 SHEET 1 of 2	
REVISIONS: Corrected typo on page two that said SHEET 1 of 2.	
<i>Paul D. Wigand</i> Brian Smith <small>SUDAS DIRECTOR DESIGN METHODS ENGINEER</small>	
CASTINGS FOR GRATE INTAKES	

TYPE S ②④
 Barrier Intake Gate
 (Minimum open area 300 in²)

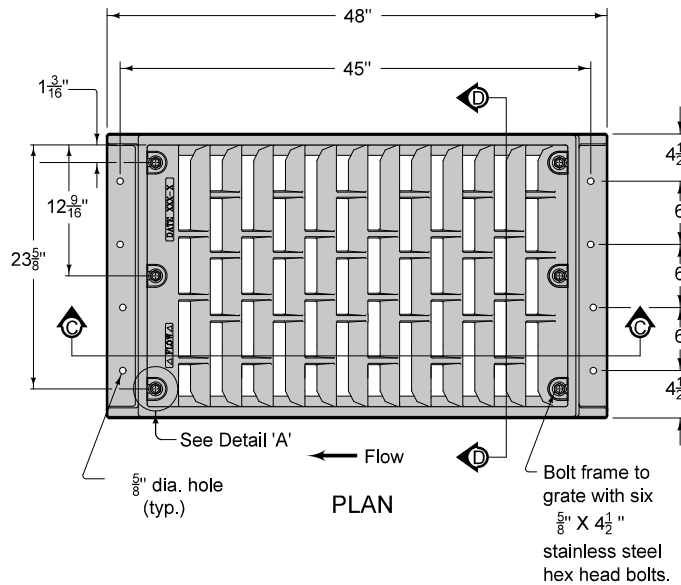
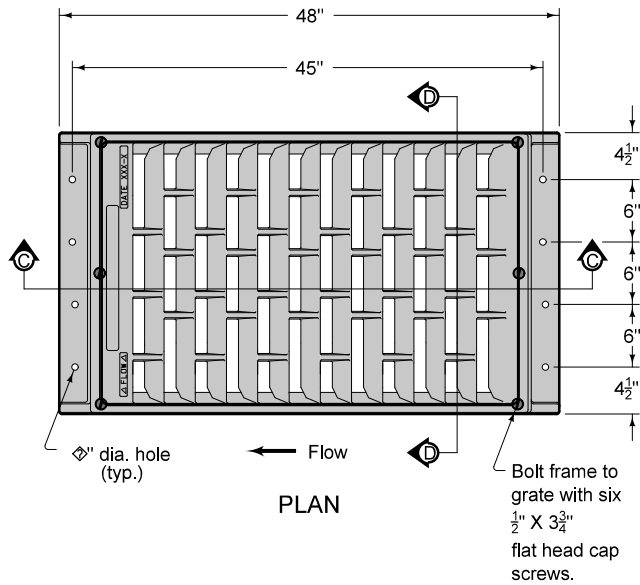

- ② Provide bicycle-safe vane-style grate. At low points, grates with vanes facing both directions of flow are allowed. The Contractor has the choice of which Type S Grate to use.
- ④ Use ductile iron frame castings meeting the requirements of ASTM A 536.

Frame minimum weight = 220 lbs.
 Grate minimum weight = 340 lbs.

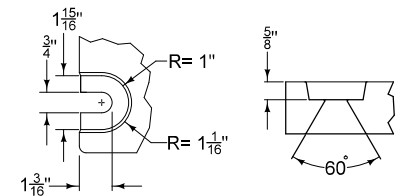

DETAIL 'A'
 Bolt Slot Detail

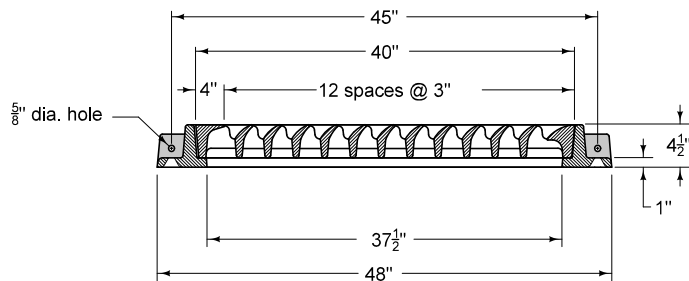

SECTION C-C

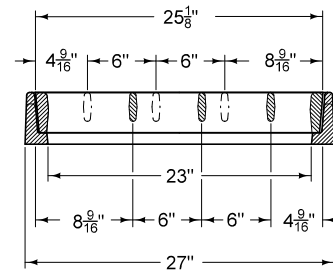

SECTION D-D

FIGURE 6010.603 SHEET 2 OF 2

SUDAS	IOWADOT	REVISION
		6 10-16-18
FIGURE 6010.603	STANDARD ROAD PLAN	SW-603
		SHEET 2 of 2
REVISIONS: Corrected typo on page two that said SHEET 1 of 2.		
<i>Paul D. Wigand</i> SUDAS DIRECTOR		<i>Brian Smith</i> DESIGN METHODS ENGINEER
CASTINGS FOR GRATE INTAKES		

TYPE 4

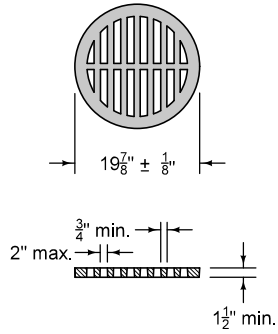

TYPE 4A

For Placement on 18" RCP

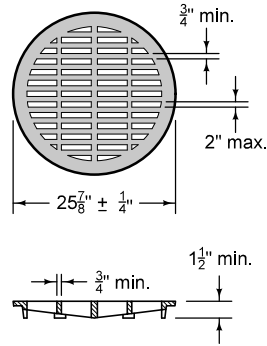

TYPE 4B

For Placement on 24" RCP

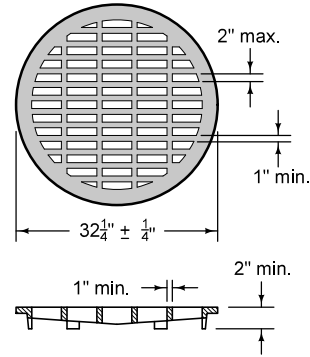

TYPE 4C

For Placement on 30" RCP

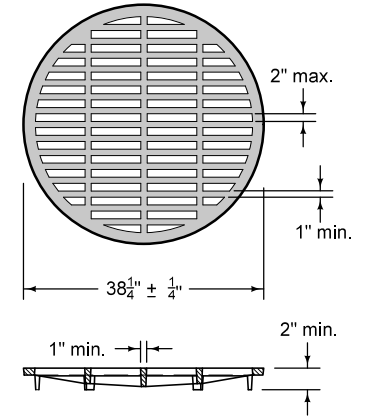

TYPE 4D

For Placement on 36" RCP

TYPE 3
(Light Duty)

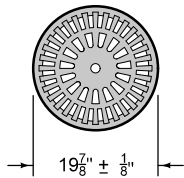

TYPE 3A

For Placement on 18" RCP

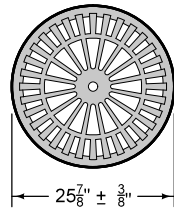

TYPE 3B

For Placement on 24" RCP

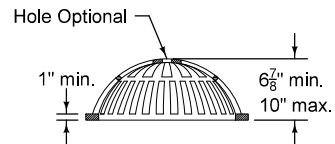
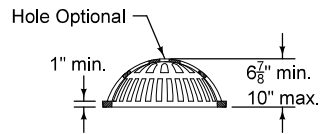

TYPE 5
(Light Duty)
For Placement on 24" to 30" RCP

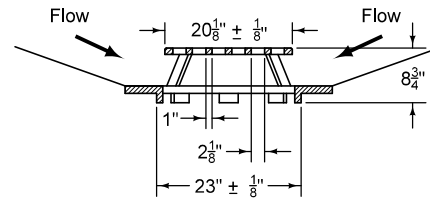
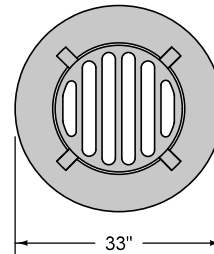

FIGURE 6010.604 | SHEET 1 OF 2

SUDAS	IOWADOT	REVISION
		3 04-21-20
FIGURE 6010.604	STANDARD ROAD PLAN	SW-604
		SHEET 1 of 2

REVISIONS: Added Type 7 casting. Modified circle notes.

Paul D. Wigand SUDAS DIRECTOR *Shawn Miller* DESIGN METHODS ENGINEER

CASTINGS FOR AREA INTAKES

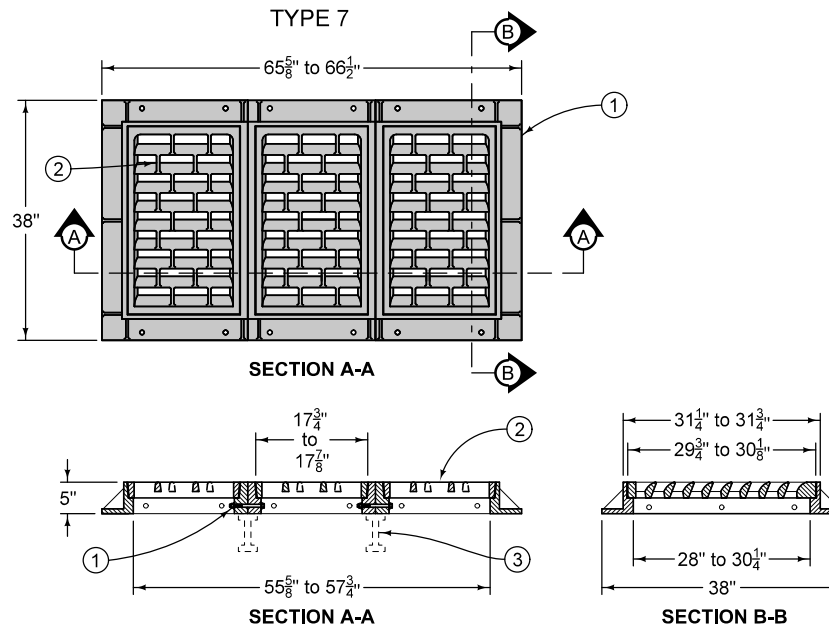
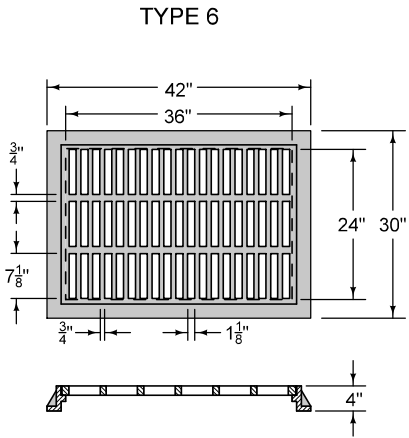

- ① Frame provided in three segments (two ends and one center). Bolt segments together as specified by the casting manufacturer.
- ② Provide bicycle safe, vane style grates with a minimum open area of 4 square feet. At low points, grates with vanes facing both directions will be allowed.
- ③ If required by casting manufacturer, provide support beam under all frame joints. Modify structure walls as required to provide pocket for beam.
- ④ Cast grate without locking lugs so it may be used in an inverted position.

TYPE 9
(Light Duty)

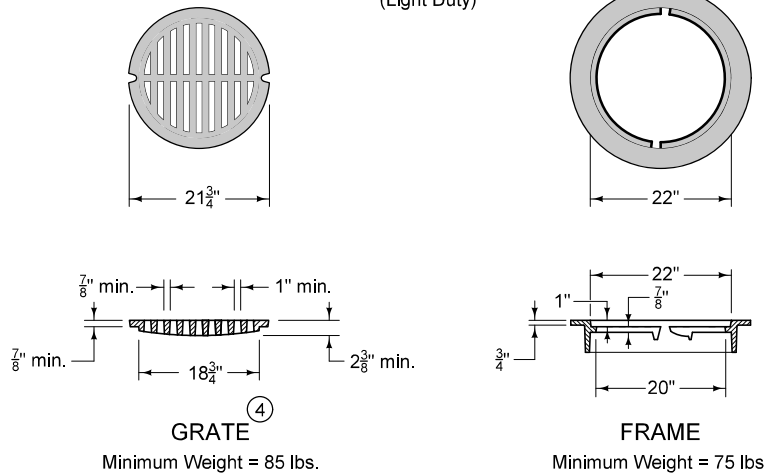

		REVISION
		3 04-21-20
FIGURE 6010.604	STANDARD ROAD PLAN	SW-604
		SHEET 2 of 2
<small>REVISIONS: Added Type 7 casting. Modified circle notes.</small>		
 SUDAS DIRECTOR		 DESIGN METHODS ENGINEER
CASTINGS FOR AREA INTAKES		

REHABILITATION OF EXISTING MANHOLES**PART 1 - GENERAL****1.01 SECTION INCLUDES**

Rehabilitation of existing manholes.

1.02 DESCRIPTION OF WORK

Rehabilitate existing manholes to waterproof and to prevent inflow and infiltration, to prevent corrosion, or to reestablish the structural integrity of the manhole. Includes construction of structural liners, protective liners, and infiltration barriers.

1.03 SUBMITTALS

Comply with Division 1 - General Provisions and Covenants, as well as the following:

- A. Concrete mix design, if required by the Engineer.
- B. Catalog cuts of all mortar mixes, sealants, and liners.

1.04 SUBSTITUTIONS

Comply with Division 1 - General Provisions and Covenants.

1.05 DELIVERY, STORAGE, AND HANDLING

Comply with Division 1 - General Provisions and Covenants.

1.06 SCHEDULING AND CONFLICTS

Comply with Division 1 - General Provisions and Covenants.

1.07 SPECIAL REQUIREMENTS

None.

1.08 MEASUREMENT AND PAYMENT**A. Infiltration Barriers:****1. Rubber Chimney Seal:**

- a. **Measurement:** Each rubber chimney seal installed on an existing manhole will be counted.
- b. **Payment:** Payment will be made at the unit price for each chimney seal.
- c. **Includes:** Unit price includes, but is not limited to, all necessary compression or expansion bands and extension sleeves as necessary to complete chimney seal.

2. Molded Shield:

- a. **Measurement:** Each molded shield installed on an existing manhole will be counted.
- b. **Payment:** Payment will be made at the unit price for each molded shield.
- c. **Includes:** Unit price includes, but is not limited to, sealant.

1.08 MEASUREMENT AND PAYMENT (Continued)**3. Urethane Chimney Seal:**

- a. **Measurement:** Each urethane chimney seal installed on an existing manhole will be counted.
- b. **Payment:** Payment will be at the unit price for each urethane chimney seal.
- c. **Includes:** Unit price includes, but is not limited to, preparing the surface of the manhole and furnishing and applying primer and urethane chimney seal according to the manufacturer's requirements.

B. In-Situ Manhole Replacement, Cast-in-place Concrete:

1. **Measurement:** The vertical dimension of in-situ manhole replacement will be measured in feet from the lowest flowline to the top of the rim.
2. **Payment:** Payment will be at the unit price per vertical foot.
3. **Includes:** Unit price includes, but is not limited to, handling of sewer flows as required to properly complete the installation, invert overlay as recommended by the manufacturer, replacement of existing casting with a new casting, and testing the manhole upon completion.

C. In-Situ Manhole Replacement, Cast-in-place Concrete with Plastic Liner:

1. **Measurement:** The vertical dimension of in-situ manhole replacement with plastic liner will be measured in feet from the lowest flowline to the top of the rim.
2. **Payment:** Payment will be at the unit price per vertical foot.
3. **Includes:** Unit price includes, but is not limited to, handling of sewer flows as required to properly complete the installation, invert overlay as recommended by the manufacturer, replacement of existing casting with a new casting, sealing at the frame and cover, sealing pipe penetrations as recommended by the manufacturer, and testing the manhole upon completion.

D. Manhole Lining with Centrifugally Cast Cementitious Mortar Liner with Epoxy Seal:

1. **Measurement:** The vertical dimension of manhole lining will be measured for depth in feet from the bottom of the lining to the top of the lining for each liner thickness specified.
2. **Payment:** Payment will be at the unit price per vertical foot for each liner thickness.
3. **Includes:** Unit price includes, but is not limited to, the handling of sewer flows during lining operations as required to properly complete the installation, and replacement of the existing casting with a new casting.

PART 2 - PRODUCTS**2.01 INFILTRATION BARRIER**

- A. Rubber Chimney Seal:** Comply with [Section 6010, 2.11](#) for external and internal rubber chimney seals.
- B. Molded Shield:** Comply with [Section 6010, 2.11](#) for molded shields.
- C. Heat Shrink Sleeve:** Comply with [Section 6010, 2.11](#) for heat shrink sleeves.
- D. Urethane Chimney Seal:** Comply with the following table for the physical properties.

Table 6020.01: Physical Properties

Property	ASTM Test Method	Acceptable Value
Elongation	D 412	800%, minimum
Tensile Strength	D 412	1150 psi, minimum
Adhesive Strength	D 903	175 lb/in, minimum
Pressure Resistance	C 1244	2 minutes

2.02 IN-SITU MANHOLE REPLACEMENT, CAST-IN-PLACE CONCRETE

- A. Forming System:** Provide an internal forming system capable of forming a new and structurally independent manhole wall within the existing manhole, with the specified thickness and conforming to the general shape of the existing manhole.
- B. Concrete:** Comply with [Section 7010, 2.01, A](#).
- C. Plastic Liner:** When specified, provide a PVC or PE plastic liner resistant to degradation by sulfuric acid. Use a liner capable of being attached to the exterior of the forming system during erection of the forms. Use a plastic liner with a ribbed or studded exterior surface suitable for anchoring to the newly formed interior wall.
- D. Casting:** Provide new casting. Comply with [Section 6010, 2.10](#).

2.03 CENTRIFUGALLY CAST CEMENTITIOUS MORTAR LINER WITH EPOXY SEAL**A. Cementitious Lining:**

1. Use a high-strength, high-build, corrosion-resistant mortar, based on Portland cement fortified with micro silica. Mixed mortar is to have a paste-like consistency that may be sprayed, cast, pumped, or gravity-flowed into any area 1/2 inch and larger.

2.03 CENTRIFUGALLY CAST CEMENTITIOUS MORTAR LINER WITH EPOXY SEAL (Continued)

2. Comply with the following table for physical properties.

Table 6020.02: Physical Properties

Property	Value
Unit Weight	102 to 130 pcf
Set Time at 70° F ASTM C 403 Initial Set / Final Set	240 minutes / 480 minutes
Modulus of Elasticity ASTM C 469 24 hours / 28 days	180,000 psi min. / 1,150,000 psi min.
Flexural Strength ASTM C 293 24 hours / 28 days	650 psi min. / 800 psi min.
Compressive Strength ASTM C 109 24 hours / 28 days	3,000 psi / 10,000 psi
Tensile Strength ASTM C 307	600 psi
Shear Bond ASTM C 882	>1,000 psi
Shrinkage ASTM C 157	None
Chloride Permeability ASTM C 1202	<550 Coulombs

3. Use a lining containing a liquid admixture for the prevention of micro-biologically induced corrosion.

B. Corrosion-Resistant Epoxy Lining:

1. Use a two-component 100% solids epoxy formulated for use in sewer systems.
2. Comply with the following table for physical properties.

Table 6020.03: Physical Properties

Property	Value
Dry Time	4-6 hours at 75° F; 50% Relative Humidity
Compressive Strength ASTM D 695	15,000 psi min.
Flexural Strength ASTM D 790	11,000 psi min.
Tensile Strength ASTM D 638	4,500 psi min.
Hardness ASTM D 2240	68 to 90 Shore D
Ultimate Elongation ASTM D 638	3.5 to 5.5 %
Adhesion ASTM D 7234	Substrate Failure

- C. **Casting:** Provide new casting. Comply with [Section 6010, 2.10](#).

PART 3 - EXECUTION**3.01 INFILTRATION BARRIER**

- A. Rubber Chimney Seal:** Comply with [Section 6010, 3.01](#).
- B. Molded Shield:** Comply with [Section 6010, 3.01](#).
- C. Urethane Chimney Seal:** Use only when specified in the contract documents.
1. Prepare the surface according to the manufacturer's recommendations, including sandblasting, pressure washing, sealing leaks or gaps, and drying the surface.
 2. Apply primer, prepare product, and brush-apply the seal to a minimum thickness of 175 mils, covering 2 inches above the bottom of the frame and the entire adjustment ring area to 3 inches below the bottom adjustment ring.

3.02 IN-SITU MANHOLE REPLACEMENT, CAST-IN-PLACE CONCRETE

- A. Preparation:** Prepare according to the forming system manufacturer's recommendations, including the following:
1. Clean the existing surface to remove loose material and debris.
 2. Remove existing steps that might interfere with the erection of the forms.
 3. Control infiltration that may affect placement of concrete.
- B. Installation:** Install and test according to the forming system manufacturer's recommendations, including the following:
1. Place pipe extensions through the structure to maintain flow during installation.
 2. Erect forms inside the manhole. Secure the assembled internal forms to prevent shifting and to provide sufficient stiffness and strength to prevent collapse.
 3. Install a plastic liner when specified.
 4. Seal the forms at the bottom of the manhole to ensure the concrete does not enter the sewer.
 5. Carefully place concrete between the forms and the existing manhole walls. Place concrete from the bottom up to prevent segregation of concrete.
 6. Consolidate concrete as required to fill all pockets, seams, and cracks within the existing manhole wall.
 7. Remove the forms when the concrete has cured sufficiently.
 8. Weld and test joints if a plastic liner is installed.
 9. Apply a sealing strip around the circumference of the invert top where it meets the vertical wall and around all pipe penetrations to form a waterstop.
 10. Overlay the invert top with concrete or high-strength mortar. Vary thickness from 3 inches at the wall to 1/2 inch at the edge of the channel.

3.02 IN-SITU MANHOLE REPLACEMENT, CAST-IN-PLACE CONCRETE (Continued)

11. Apply an epoxy lining to the invert top. Apply clean sand to the epoxy to create a non-slip surface.
12. Seal the plastic liner to the manhole casting and existing pipe stubs as recommended by the manufacturer.
13. Install new casting.

3.03 CENTRIFUGALLY CAST CEMENTITIOUS MORTAR LINER WITH EPOXY SEAL

A. Surface Preparation: Prepare according to the manufacturer's recommendations, including the following:

1. Wash the interior with a high-pressure washer.
2. Plug active leaks with the appropriate sealing material.

B. Mortar Application: Apply according to the manufacturer's recommendations, including the following:

1. Apply with a rotating centrifugal casting applicator, beginning at the bottom of the manhole.
2. Retrieve the applicator head at the manufacturer's recommended speed to achieve the desired thickness.
3. Apply to the full required thickness utilizing multiple passes as necessary. Minimize the time between passes so subsequent passes are cast against fresh mortar.
4. Verify thickness with a wet gauge at several locations to ensure proper depth.
5. Hand-apply high-strength mortar to the invert surface. Vary thickness from 3 inches at the wall to 1/2 inch at the edge of the channel.

C. Epoxy Seal Application: Seal according to the manufacturer's recommendations, including the following:

1. Apply with a rotating centrifugal casting applicator or airless sprayer onto the fresh mortar liner.
2. If the epoxy seal is applied more than 24 hours after application of the mortar liner, or if the mortar liner is contaminated, clean the liner and then apply the epoxy.

D. Finishing: Install a new casting.

3.04 CLEANING, INSPECTION, AND TESTING

Comply with [Section 6030](#) for in-situ manhole replacement and centrifugally cast mortar lined rehabilitation.

END OF SECTION

CLEANING, INSPECTION, AND TESTING OF STRUCTURES

PART 1 - GENERAL

1.01 SECTION INCLUDES

- A. Cleaning, inspecting, and testing sanitary sewer manholes.
- B. Cleaning and inspecting storm sewer manholes, intakes, and other utility structures.

1.02 DESCRIPTION OF WORK

- A. Clean, inspect, and test sanitary sewer manholes.
- B. Clean and inspect storm sewer manholes, intakes, and other utility structures.

1.03 SUBMITTALS

Comply with Division 1 - General Provisions and Covenants.

1.04 SUBSTITUTIONS

Comply with Division 1 - General Provisions and Covenants.

1.05 DELIVERY, STORAGE, AND HANDLING

Comply with Division 1 - General Provisions and Covenants.

1.06 SCHEDULING AND CONFLICTS

Comply with Division 1 - General Provisions and Covenants, as well as the following:

- A. Notify the Engineer at least 24 hours prior to performing testing.
- B. The Engineer must be present to review testing procedures and record results.

1.07 SPECIAL REQUIREMENTS

None.

1.08 MEASUREMENT AND PAYMENT

Cleaning, inspection, and testing of structures are incidental to construction of structures and will not be paid for separately.

PART 2 - PRODUCTS

None.

PART 3 - EXECUTION**3.01 CLEANING**

- A. Clean all manholes, intakes, and structures by removing sheeting, bracing, shoring, forms, soil sediment, concrete waste, and other debris.
- B. Do not discharge soil sediment or debris to drainage channels or existing storm sewer or sanitary sewer system.

3.02 VISUAL INSPECTION

- A. Examine structure for:
 - 1. Damage.
 - 2. Slipped forms.
 - 3. Indication of displacement of reinforcement.
 - 4. Porous areas or voids.
 - 5. Proper placement of seals, gaskets, and embedments.
- B. Verify that the structure is set to true line, grade, and plumb.
- C. Verify structure dimensions and thicknesses.

3.03 REPAIR

Comply with [Section 6010](#) for repairs.

3.04 SANITARY SEWER MANHOLE TESTING**A. General:**

- 1. Use vacuum testing for sanitary sewer manholes, unless exfiltration testing is specified in the contract documents.
- 2. Conduct the final test after manhole construction is complete, all repairs and connections have been made, and the invert has been installed.

B. Vacuum Test:

- 1. Applicable only for new manholes isolated from connecting sewer lines.
- 2. Use manufactured vacuum test equipment meeting the Engineer's approval. Follow the equipment manufacturer's recommended procedures throughout, unless directed otherwise by the Engineer or these specifications.
- 3. Use extreme care and follow safety precautions during testing operations. Keep personnel clear of manholes during testing.
- 4. Seal all openings except manhole top access using pneumatic plugs rated for test pressures. Install plugs according to the test equipment manufacturer's recommendations.
- 5. Brace pipe inverts if backfill material has not been placed around connecting pipes.

3.04 SANITARY SEWER MANHOLE TESTING (Continued)

6. Install the vacuum tester head assembly on the manhole top access, and inflate the seal.
7. Evacuate the manhole to 5 psi or 10 inches mercury (Hg). Close the isolation valve and start the test. Record the starting time.
8. Maintain a vacuum in the manhole for the time indicated in the following table for the diameter and depth of manhole being tested.
9. Test failure is indicated by vacuum loss greater than 0.5 psi or 1 inch mercury (Hg) within the minimum test time indicated in the table below for the depth and diameter of the manhole being tested.

Table 6030.01: Minimum Vacuum Test Times for Various Manhole Diameters

Depth (feet)	Diameter (inches)				
	48	54	60	66	72
	Time (seconds)				
8	20	23	26	29	33
10	25	29	33	36	41
12	30	35	39	43	49
14	35	41	46	51	57
16	40	46	52	58	67
18	45	52	59	65	73
20	50	53	65	72	81
22	55	64	72	79	89
24	59	64	78	87	97
26	64	75	85	94	105
28	69	81	91	101	113
30	74	87	98	108	121

C. Exfiltration Test:

1. Testing may be performed in conjunction with sanitary sewer line testing. Comply with [Section 4060](#).
2. Do not test by this method if water may potentially freeze during the test.
3. Plug the manhole inlet and outlet.
4. Fill the manhole with water to 2 feet above the outside top of the connecting pipe. If ground water is present, fill the manhole to no less than 2 feet nor more than 5 feet above the ground water level. Do not fill above the top of the standard barrel sections.
5. Mark the water level.
6. Allow water to stand in the manhole for 1 hour, then refill to the original water level and begin the test.
7. Determine the allowable drop in water level by using the equation given in [Section 4060, 3.03](#). After 1 hour, measure the drop in water level.
8. Test failure is indicated by water loss greater than the maximum allowable calculated exfiltration.

3.05 TEST FAILURE

If testing fails, reseal the openings, repair the manhole, and retest. An alternate test method complying with these specifications may be used for a retest if desired.

END OF SECTION