

Types of Joints

A. Jointing

PCC pavement joints are necessary primarily to control the location of cracks that occur from natural and dynamic loading stresses. They accommodate stresses that develop from slab curling and warping due to moisture and temperature differentials and traffic loading. In addition, joints divide the pavement into suitable construction increments or elements. Standard design considerations include joint types, spacing, load transfer, and filling. This section deals with the proper selection and layout of contraction, construction, and isolation joints.

B. Joint Spacing

Joint spacing for unreinforced concrete pavements depends on slab thickness, concrete aggregate, subgrade/subbase support, and environmental conditions. Transverse joint spacing should be limited to 24T (T is slab thickness) for pavements on subgrades and granular subbases or 21T if the pavement is placed on stabilized subbases, existing concrete, or asphalt. Transverse joint spacing is 12 feet for pavements 6 inches thick, 15 feet for pavements 7 to 9 inches thick, and 17 feet for pavements over 9 inches thick. Longitudinal joint spacing for two lane streets, where lane delineation is not necessary, should be limited to a maximum of 10 feet. For multi-lane streets, where lane delineation is desired, longitudinal joint spacing is typically 10 to 12 feet. Generally, transverse joint spacing should not exceed 150% of the longitudinal joint spacing. Table 5G-2.01 provides transverse joint spacings for standard two lane streets.

Table 5G-2.01: Transverse Joint Requirements

Pavement Thickness	Transverse Joint Type	Transverse Joint Spacing
6"	C	12'
7"	C	15'
8"	CD ¹	15'
9"	CD ¹	15'
≥ 10"	CD ¹	17'

¹ No dowels within 24" of the back of curb

Source: [SUDAS Specifications Figure 7010.901](#)

C. Joint Types

Contraction joints for concrete pavements are generally sawed. Transverse joints can be sawed with conventional sawing or early concrete sawing equipment. Longitudinal joints are formed with conventional sawing. Some joints, including construction joints, are formed. The figures in this subsection are derived from [SUDAS Specifications Figure 7010.101](#).

1. **Transverse Contraction Joints:** Contraction joints constructed transversely across pavement lanes are spaced to control natural initial and mature cracking of the concrete pavement. Under certain conditions, such as rapidly dropping air temperature during the night, transverse cracks may occur early. Therefore, early formation of the transverse joints is required.
 - a. **Plain Contraction Joints:** Plain contraction joints are normally used in local streets and minor collectors where load transfer is not a major factor. Load transfer for plain contraction joints occurs through the adjacent irregular fractured faces. Generally, they are used when the slab thickness is less than 8 inches. The joints are constructed by sawing to a depth of $T/4$. See SUDAS Specifications Figure 7010.901 for joint spacing for 6 and 8 inch thick slabs. Plain contraction joints are sometimes used when the pavement thickness is 9 inches or greater such as at intersections in boxouts near curbs where load transfer is not a concern. Approved early concrete sawing equipment may be used to cut the joint to a depth of 1 1/4 inch. For filling, the joint width must be a minimum of 1/4 inch wide.

Figure 5G-2.01: 'C' Plain Contraction Joint

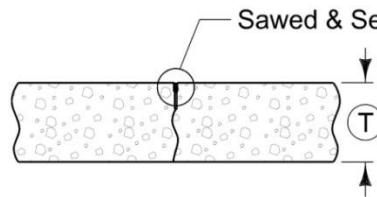

- b. **Doweled Contraction Joints:** Dowel bars are used to supplement the load transfer produced by aggregate interlock. The joints are sawed to a depth of $T/3$ and are spaced at 15 foot intervals for slab thickness of 9 inches or less and 17 feet for slabs greater than 9 inches thick. The dowels are placed at the mid-depth in the slab so they can resist shear forces as traffic loads cross the joint; thus helping reduce deflection and stress of the joint. The need for doweled contraction joints depends on subgrade/subbase support and the truck traffic loadings the roadway is to provide. They are usually used on streets or roadways where the pavement thickness is 8 inches or greater and where the pavement is subject to heavier truck traffic, generally more than 100 trucks per lane per day. Early entry concrete sawing can be used for 'CD' joints.

Dowels should not be placed closer than 24 inches from the back of the curb on streets with quarter point or third point jointing. If gutterline jointing is used, place the first dowel in the traffic lane 6 inches from the joint.

Figure 5G-2.02: 'CD' Doweled Contraction Joint

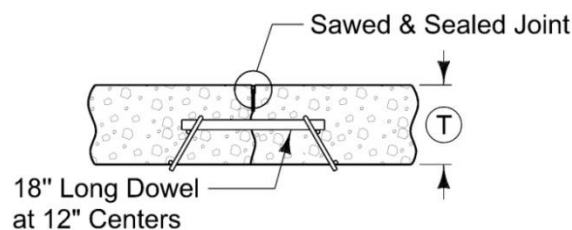

2. **Longitudinal Contraction Joints:** Longitudinal contraction joints release stresses from restrained warping and dynamic loading. Under certain conditions, such as rapidly dropping air temperature during the night, longitudinal cracks may occur early. Therefore, early formation of the joint is required.

Typically, sawed longitudinal joints are filled. However, since the slabs on either side of the longitudinal contraction joint are tied by a reinforcing bar, the Jurisdictional Engineer may approve not filling the joint. The need to fill the joint is reduced due to the tied connection and the fact the joint will not open. The depth of cut for sawed longitudinal joints is $T/3$, regardless of the method of sawing used. The width of the filled joints is $1/4$ inch \pm $1/16$ inch. The maximum width of the unfilled joints is $1/8$ inch \pm $1/16$ inch.

A longitudinal joint is usually placed at the center of the pavement to allow the pavement to hinge due to lane loading and help delineate separation of opposing traffic. Controlling cracking and proper constructability are the primary functions of longitudinal contraction joints. Lane delineation is a secondary function.

Figure 5G-2.03: Longitudinal Contraction Joints

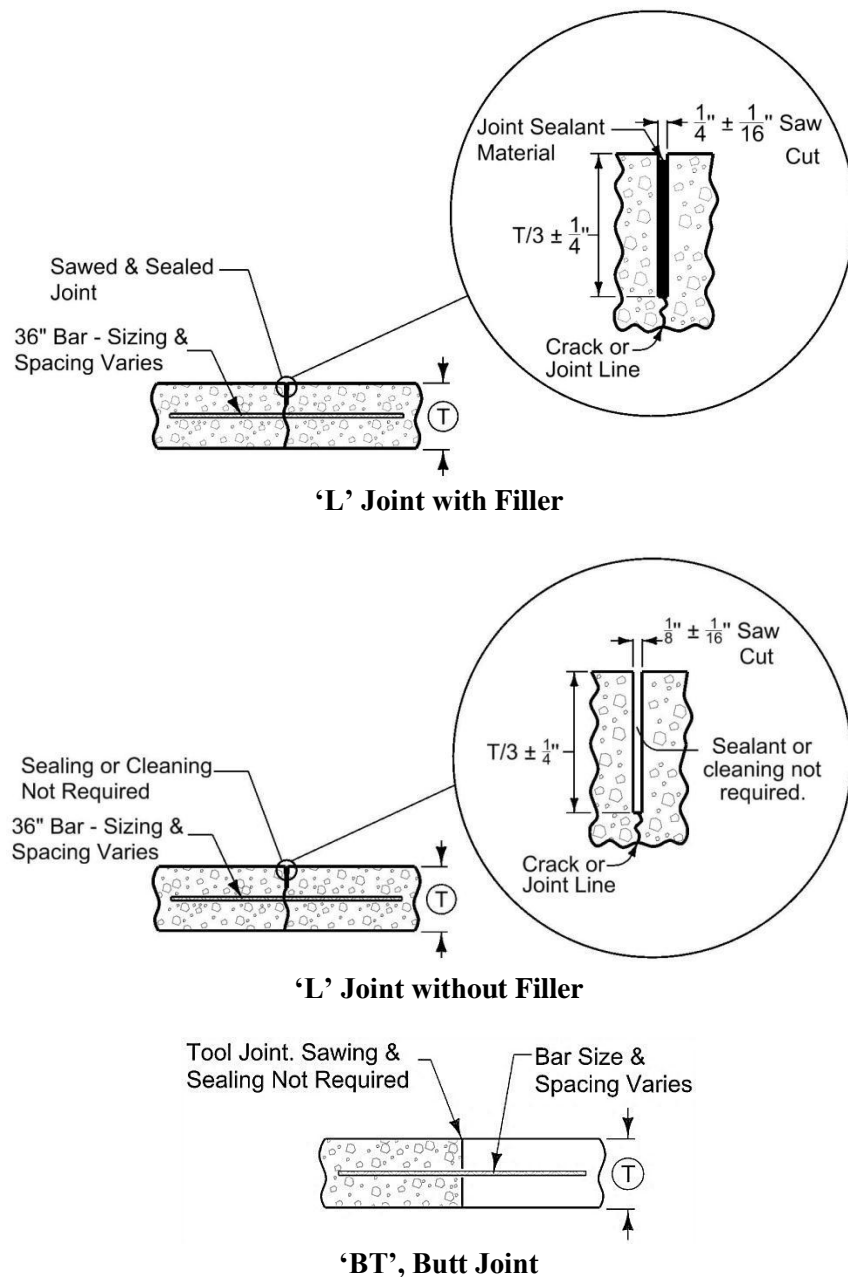

An important consideration when establishing the distance between longitudinal joints for jointed plain concrete pavements is the prevention of random longitudinal cracking at the quarter point, which is the midpoint between the centerline and the back of the curb. Pavements less than 9 inches thick may not crack through a longitudinal joint placed close to the gutter, which could cause longitudinal cracks at the quarter point.

- a. **Quarter Point Jointing** is the preferred layout for longitudinal pavement joints. This pattern, for all pavement widths, is the best option to induce cracking at the planned locations.
- b. **Third Point Jointing**, which eliminates the centerline joint, is frequently used and recommended for pavements 30 feet or narrower. It is only recommended for pavements wider than 30 feet when pavement depths are greater 8 inches.
- c. **Gutterline Jointing** with a centerline joint is favored by some jurisdictions. This pattern has a centerline joint with gutterline joints 3 to 3 1/2 feet from the back of curb. It is recommended that this jointing pattern be only used on pavements depths of at least 9 inches or pavements where a widening is likely to occur, because, as stated above, the longitudinal joints close to the gutter may not activate. This would increase the likelihood of random cracking at the quarter point.

The following examples depict jointing options for 26 foot and 31 foot wide pavements. The principles involved with jointing for these pavement widths can be extended to other pavement widths.

- a. **26 Foot B-B Pavement:** Three longitudinal joint options for 26 foot wide plain jointed concrete pavements are provided:
 - 1) Quarter point jointing includes a centerline joint and two joints at the quarter points. This option is used when centerline crack control is desired.
 - 2) Third point jointing provides for a single 9 foot center panel with two joints, each 8 1/2 feet from the back of curb.
 - 3) Gutterline jointing provides two 10 foot lanes with a centerline joint and gutterline joints 3 feet from the back of curb. As stated above, care must be exercised with this option to prevent random cracking at the quarter point. This option is typically used for streets 9 inches or greater in thickness.

Figure 5G-2.04: 26 Foot B-B Pavement

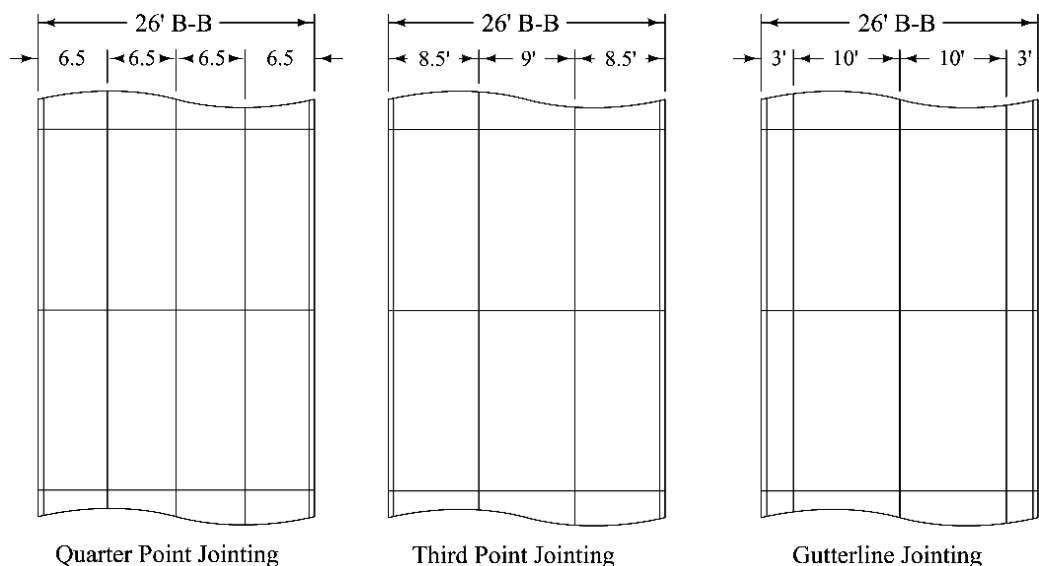

- b. 31 Foot B-B Pavements:** Three longitudinal joint options for 31 foot wide pavements are provided.
- 1) Quarter point jointing provides for a centerline longitudinal joint and two quarter point joints and is not intended to delineate driving lanes.
 - 2) Third point jointing provides three nearly equally spaced panels, without a centerline joint. It typically is used as an option to quarter point jointing to minimize the number of longitudinal joints.
 - 3) Gutterline jointing utilizes a centerline joint and gutterline joints 3 to 3 1/2 feet from the back of curb that delineate driving lanes. This jointing pattern is typically used when the pavement may be widened in the future, and the delineation of the lanes is desired. Care must be exercised with this option to prevent random cracking at the quarter point. Typically, gutterline jointing is used on streets with pavement thickness greater than or equal to 9 inches.

Figure 5G-2.05: 31 Foot B-B Pavements

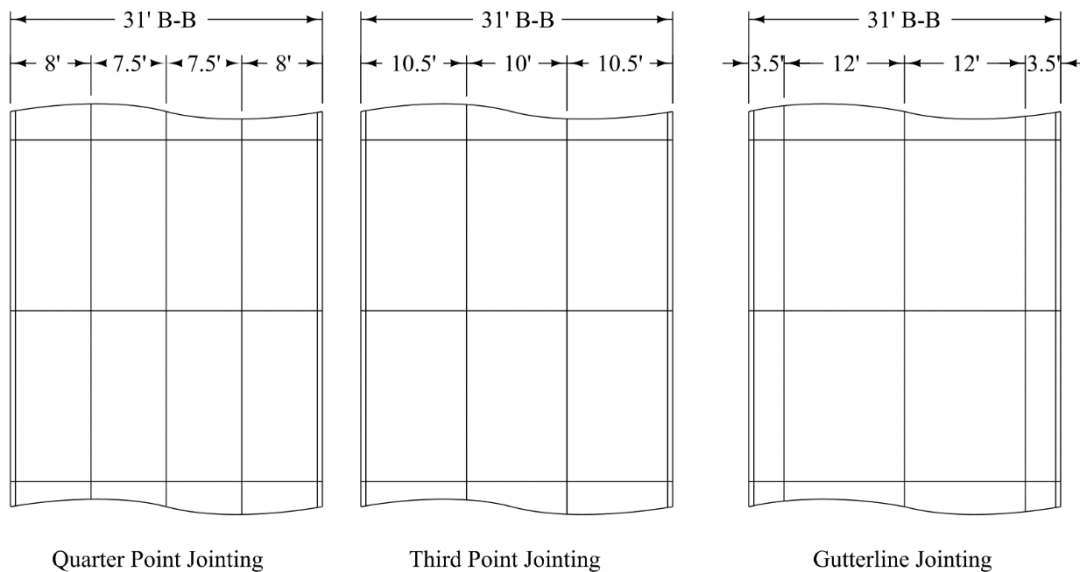

- 3. Transverse and Longitudinal Construction Joints:** Construction joints are necessary for planned construction interruptions or widening/extending a pavement. Examples include construction of adjacent lanes at different times; box-outs for structures, radii, etc.; planned gaps in the paving operation such as at driveways, bridges, and intersections; paving operation stoppages for over 30 minutes; and when a joint is needed between dissimilar materials. Construction joints are also used between an existing pavement and a new pavement. The joint is formed with the existing slab and is not sawed, except to accommodate joint filling when required. Sawing and filling of the joints are not required for those tied with deformed bars.
- a. Transverse Construction Joints:** These types of joints are usually butt-type joints with deformed tie bars or dowels to provide load transfer and prevent vertical movement. Because DW joints are tied, they should be located mid-panel or no closer than 5 feet to a planned contraction joint. When joint filling is required, the depth of the saw cut (1 1/4 inches) is just deep enough to provide a reservoir for the joint filler. The following are typical transverse construction joints.

Figure 5G-2.06: Transverse Construction Joints

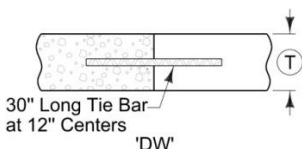
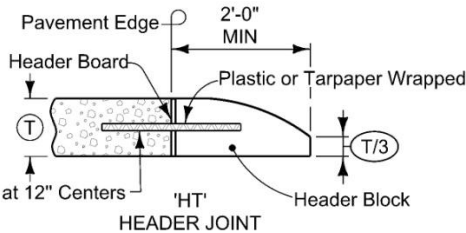
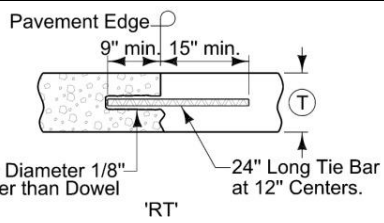
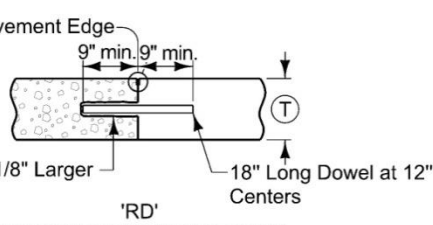
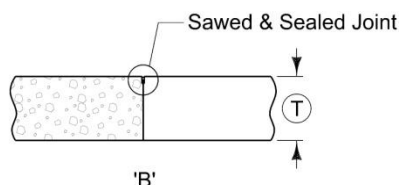
 <p>30" Long Tie Bar at 12" Centers 'DW' DAY'S WORK JOINT (Non-working)</p>	<p>Used at planned or unplanned stopping points. Ideally, it should be located at mid-panel, but it should not be located less than 5 feet from a planned contraction joint.</p>
 <p>Pavement Edge Header Board Plastic or Tarpaper Wrapped 30" Long Tie Bar at 12" Centers 'HT' HEADER JOINT (End Rigid Pavement) Header Block 2'-0" MIN</p>	<p>Used when the pavement ends and traffic will cross the joint. The header is removed when the pavement is extended.</p>
 <p>Pavement Edge 9" min. 15" min. Hole Diameter 1/8" Larger than Dowel 'RT' ABUTTING PAVEMENT JOINT RIGID TIE 24" Long Tie Bar at 12" Centers.</p>	<p>Typically used when an existing slab is extended.</p>
 <p>Pavement Edge 9" min. 9" min. Hole Diameter 1/8" Larger than Dowel 'RD' ABUTTING PAVEMENT JOINT 18" Long Dowel at 12" Centers</p>	<p>Functions as a CD joint when an existing slab is extended. Normally used when the pavement is 8 inches or greater in thickness.</p>
 <p>Sawed & Sealed Joint 'B' PLAIN JOINT (For Abutting Pavement Slabs)</p>	<p>Typically used when two different pavement types or thicknesses abut or at the inside longitudinal edge of intake boxouts.</p>

b. Longitudinal Construction Joints: These types of joints are used when adjacent lanes are constructed at different times. Tie-bars are primarily designed to resist horizontal movement but help with load transfer and vertical control. Under certain conditions, such as a drop in air temperature during the first night, longitudinal and transverse cracks may occur early. Early sawing of transverse joints is important when tied longitudinal construction joints are constructed in order to prevent the following two conditions from occurring.

- 1) Sympathy Transverse Cracking in New Lane Construction:** When a new slab is longitudinally tied to an existing pavement, the existing transverse contraction joints can cause adjacent lane cracking in the new slab if early sawing of the transverse joints is not done. If there are transverse random cracks in an existing slab, the longitudinal

construction joint should be a plain butt joint or keyed joint (with no tie bars), if one exists in the old slab, to prevent sympathy cracks in the new pavement.

- 2) **Longitudinal Tie-bar Stress in Cooler Weather Conditions:** Care must be exercised to control cracking when utilizing longitudinal construction joints with tie bars, particularly in cool temperatures. For example, when a lane is constructed one day and the adjacent lane is constructed the following day or later, the existing lane could be expanding, particularly in the morning. If the new lane is in its final set (contracting) at the same time the existing pavement is expanding, stresses in the concrete at the tie bars can be significant. If the strength of the new concrete has not developed enough to resist the stresses, cracking could occur in the new concrete at the tie bars. During cooler weather conditions, care should be exercised when paving the new lane. Ideally, the new paving operation should take place at mid-day or later when the existing lane expansion is reduced.

Figure 5G-2.07: Longitudinal Construction Joints

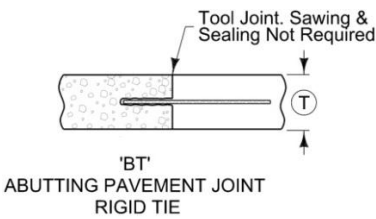
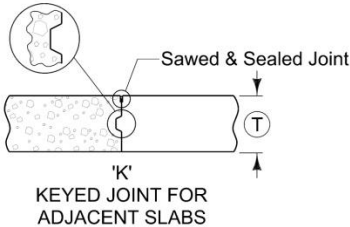
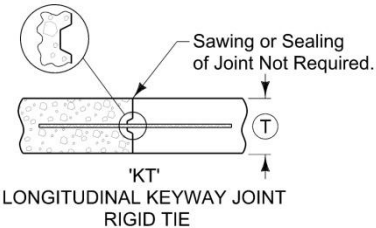
	<p>Used to tie existing and new parallel pavements together to prevent horizontal movements; and will provide some load transfer and resist vertical movement.</p>
	<p>Used when tie bars are not needed or desired and load transfer is required.</p>
	<p>Used in pavements under heavier traffic conditions and typically where the pavement thickness is 8 inches or greater. Also used at intersections under heavy turning movements where the pavement is less than 8 inches.</p>

4. **Isolation Joints and Expansion Joints:** Expansion and isolation joints accommodate anticipated differential horizontal and vertical movements that occur between a pavement and structure. Their purpose is to allow movement without damaging adjacent structures or pavements. Contraction or control joints also absorb some movement; however, their main function is to control the location and geometry of the natural cracking pattern in the concrete slab. Because pavement performance can be significantly affected by the planned use and location of isolation and expansion joints, care should be taken in their design. Though the terms are sometimes used interchangeably, isolation joints are not expansion joints.

- a. **Isolation Joints:** Isolation joints isolate the pavement from a structure, another paved area, or an immovable object. Isolation joints include full depth, full width joints found at bridge abutments, intersections, or between existing and new pavements. The term “isolation joint” also applies to joints around in-pavement structures such as drainage inlets, manholes, footings, and lighting structures. Isolation joints lessen compressive stresses that develop at T and unsymmetrical intersections, ramps, bridges, building foundations, drainage inlets, manholes, and anywhere differential movement between the pavement and a structure may take place. They are also placed adjacent to existing pavements, especially when it is not possible or desirable to match joint locations in the older pavement. Isolation joints should be 1/2 to 1 inch wide. Greater widths may cause excessive movement. They are filled with a pre-formed joint filler material to prevent infiltration of incompressibles.

At T-intersections, isolation joints should be used to isolate the T-intersecting street from the through street. Also, all legs of skewed streets should be isolated from the through street. Isolation joints used for this purpose should be placed one joint spacing back from the end of the intersection radii.

The joint filler material for expansion and isolation joints occupies the gap between the slabs and must be continuous from one pavement edge to the other and through curb and gutter sections. This filler material is usually a non-absorbent, non-reactive, non-extruding material typically made from either a closed-cell foam rubber or a bitumen-treated fiber board. No plug or sliver of concrete should extend over, under, through, around, or between sections of the filler, or it will cause spalling of the concrete. After the concrete hardens, the top of the filler may be recessed about 3/4 inch below the surface of the slab to allow space for the joint filler to be placed later.

- 1) **Doweled Isolation Joints:** Isolation joints used at structures should have dowels to provide load transfer. The end of the dowel must be equipped with a closed-end expansion cap into which the dowel can move as the joint expands and contracts. The cap must be long enough to cover 2 inches of the dowel and have a suitable stop to hold the end of the cap at least the width of the isolation joint plus 1/4 inch away from the end of the dowel bar. The cap must fit the dowel bar tightly and be watertight. The half of the dowel with the capped end must be coated to prevent bonding and allow horizontal movement.
- 2) **Special Undoweled Isolation Joints:** Isolation joints at T and unsymmetrical intersections or ramps are not doweled so that horizontal movements can occur without damaging the abutting pavement. Undoweled isolation joints can be constructed with thickened edges to reduce the stresses developed at the slab bottom. The abutting edges of both pavements should be thickened by 20% starting with a taper 5 feet from the joint. The isolation filler material must extend completely through the entire thickened-edge slab.

Figure 5G-2.08: Thickened Edge Joint

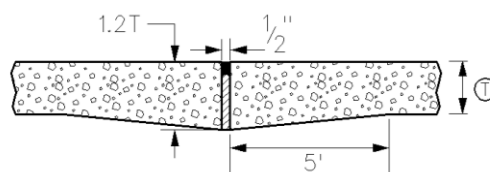

- a) **Undoweled Isolation Joints for Boxouts:** Isolation joints used at drainage inlets, manholes, and lighting structures do not have thickened edges or dowels.

- b) **Adjusting Isolation Joints for Utility Fixtures:** After developing the jointing plan, plot any catch basins, manholes, or other fixtures that are within the intersection. Non-telescoping manholes will require a boxout or isolation joint to allow for vertical and horizontal slab movement. Consider using rounded boxouts to avoid crack-inducing corners. Also, for square boxouts, wire mesh or small-diameter reinforcing bars in the concrete around any interior corners will hold cracks tight should they develop. Telescoping manholes can be cast integrally within the concrete, and do not necessarily require a boxout. The multiple piece casting does not inhibit vertical movement and is less likely to create cracks within the pavement.

When a joint is within 5 feet of a fixture, it is desirable to adjust the joint so that it will pass through the fixture or the boxout surrounding the fixture. The following diagram shows several acceptable ways to skew or shift a joint to meet fixtures.

- b. **Expansion Joints:** Expansion joints are defined as full depth, full width transverse joints placed at regular intervals of 50 to 500 feet (with contraction joints in between). This is an old practice that was used to relieve compressive forces in pavement. Unfortunately, this practice often caused other problems in the pavement such as spalling, pumping, faulting, and corner breaks.

Good design, construction, and maintenance of contraction joints has virtually eliminated the need for expansion joints, except under special conditions. In addition to the problems listed above, the improper use of expansion joints can lead to high construction and maintenance costs, opening of adjacent contraction joints, loss of aggregate interlock, filler failure, joint infiltration, and pavement growth. By eliminating unnecessary expansion joints, these problems are removed and the pavement will provide better performance.

Pavement expansion joints are only needed when:

- 1) The pavement is divided into long panels (60 feet or more) without contraction joints in between to control transverse cracking.
- 2) The pavement is constructed while ambient temperatures are below 40°F.
- 3) The contraction joints are allowed to be infiltrated by large incompressible materials.
- 4) The pavement is constructed of materials that in the past have shown high expansion characteristics.

Under most normal concrete paving situations, these criteria do not apply. Therefore, expansion joints should not normally be used (PCA, 1992).

See the following SUDAS Specifications Figures:

- [Figure 6010.508 - Single Open-Throat Curb Intake, Large Box](#)
- [Figure 6010.514 - Boxout for Grate Intakes](#)
- [Figure 7010.103 - Manhole Boxouts in PCC Pavement](#)

Table 5G-2.02: Summary of Joints
(Derived from the [Iowa DOT Design Manual, Section 7A-2](#), Tables 1 and 2)

Joint	Type			Method of Load Transfer				Thermal Movement				Comments
	Transverse	Longitudinal	Isolation/Expansion	Aggregate Interlock	Key	Tie Bar	Dowel Bar	Doweled to allow movement	Tied to prevent movement	Isolation/Expansion joint allows movement	Lack of reinforcing allows movement	
B	X	X									X	Used between dissimilar materials or when other joints are not suitable.
C	X			X							X	Transverse joint used when T < 8 inches.
CD	X			X			X	X				Transverse joint used when T ≥ 8 inches.
CT	X			X		X			X			Specialty tied contraction joint.
DW	X					X			X			Used by contractor as a stopping point.
HT	X					X			X			Used at the end of rigid pavement prior to placement of second slab.
RD	X						X	X				Joint between new and existing pavements, dowels are used.
RT	X					X			X			Joint between new and existing pavements, tie bars are used.
BT-1		X							X			Longitudinal joint used when T < 8 inches, interchangeable with L-1 depending on paving sequence.
BT-2		X							X			Used when L-2 and the KT-2 are not possible, T ≥ 8 inches.
BT-3		X							X			Joint used between new and existing pavements. Tie bars are used when T ≥ 8 inches.
BT-4		X							X			Joint used between new and existing pavements. Tie bars are used when T ≥ 8 inches.
BT-5		X							X			Joint used between new and existing pavements. Tie bars are used when T < 8 inches.
K		X			X						X	T > 8 inches, minimal usage.
KS		X			X				X			Used in reinforced pavements.
KT-1		X			X				X			Longitudinal joint used when T < 8 inches, interchangeable with L-1 depending on paving sequence.
KT-2		X			X				X			Longitudinal joint used when T ≥ 8 inches, interchangeable with L-2 depending on paving sequence.
KT-3		X			X				X			Longitudinal joint used when T ≥ 8 inches, interchangeable with L-3 depending on paving sequence.
L-1		X		X					X			Longitudinal joint used when T < 8 inches, interchangeable with BT-1.
L-2		X		X					X			Longitudinal joint used when T ≥ 8 inches, interchangeable with KT-2 depending on paving sequence.
L-3		X		X					X			Longitudinal joint used with pavements of large width, interchangeable with KT-3 depending on paving sequence.
CF	X		X							X		4 inch expansion joint.
E	X	X	X							X		1 inch expansion joint.
ED	X		X				X	X		X		1 inch doweled expansion joint.
EE	X		X				X	X		X		2 inch doweled expansion joint.
EF	X		X				X	X		X		4 inch doweled expansion joint.
ES			X							X		Used in curb to match expansion joint in pavement.

D. Transverse Dowel Bar Size and Length

Table 5G-2.03 reflects the dowel bar size and length based on the pavement thickness. This information was obtained from the Portland Cement Association, the American Concrete Paving Association, and American Highway Technology. The SUDAS and Iowa DOT Specifications call for dowels when the slab is 8 inches or greater. Dowels are typically set at 12 inch spacing. The designer should note that a dowel bar that is too small induces high bearing stresses and causes the concrete matrix around the dowel to deteriorate or elongate. Elongation of the dowel bar hole then reduces the load transfer capabilities. Under special circumstances, smaller diameter and different shaped dowel bars may be used in thinner slabs.

Table 5G-2.03: Dowel Bar Size and Length

Pavement Thickness (inches)	Dowel Size (diameter in inches)	Dowel Length (inches)
8	1 1/4	18
9	1 1/4	18
10	1 1/2	18
11	1 1/2	18
12	1 1/2	18

E. Jointed Reinforced Concrete Pavements

Jointed reinforced concrete pavements (JRCP), sometimes referred to as distributed steel reinforcing, are not commonly used in Iowa jurisdictions. However, variations of JRCP are used effectively by several jurisdictions in Iowa. Therefore, the following is provided as an explanation of JRCP.

JRCs utilize bar mats between transverse joints. Typically, the bar mats extend full width across the pavement, but with traditional JRCs, they do not extend through the transverse joints. JRCs use many of the same types of joints as jointed plain concrete pavements (JPCP), but the tie bars for longitudinal joints are replaced with the bar mats. Transverse joints, including doweled joints, are the same for both types of pavements since the bar mats of traditional JRCP do not extend through the transverse joints. Because of the bar mats, transverse joint spacing can be much longer than with JPCP, usually 27 feet to 45 feet. JRCP should not be confused with continuously reinforced pavement, which has very few or no joints.

JRCs are used primarily to control cracking of concrete pavements, to provide for load transfer between joints, and to maintain the structural integrity of the slab between transverse joints. Just like JPCPs, random cracking of JRCs may still occasionally occur even though the steel is present. The steel serves to hold the cracks close together, thus preventing the progressive opening of the cracks over time.

The added cost of the additional reinforcement for JRCs is often offset by specifying a somewhat thinner slab. However, as pointed out by the American Concrete Institute (ACI), “the use of reinforcing steel will not add to the load-carrying capacity of the pavement nor compensate for poor subgrade preparation or poor construction practices.” By holding random cracks tightly closed, it will maintain the shear resistance of the slab, and, consequently, will maintain its load carrying capacity. This improves the ride when the vertical displacement is controlled.

As mentioned previously, several jurisdictions in Iowa specify a variation of JRCP. The Iowa variations of JRCP typically include extending the longitudinal reinforcing bars through the ‘C’ plain transverse contraction joints. When ‘CD’ doweled transverse joints are specified, the longitudinal

reinforcement does not extend through the transverse joints. In addition, the transverse joint spacing is generally not lengthened as described for traditional JRCPs and follows the same guidelines as for JPCP. Figures 5G-2.09 and 5G-2.10 illustrate JRCP details typically used in Iowa.

Figure 5G-2.09: Iowa Jointed Reinforced Pavement Detail - 26' Back-To-Back Street

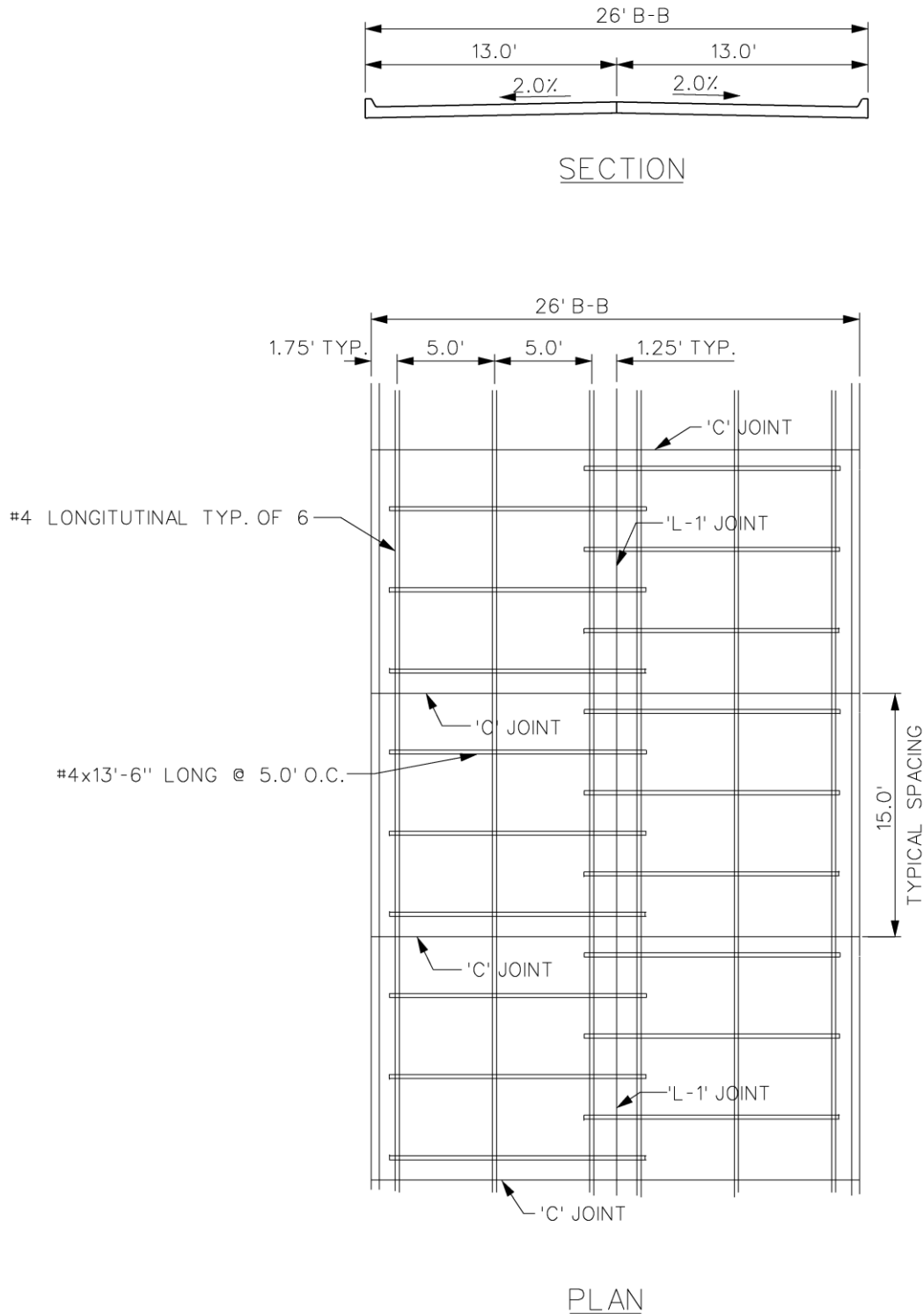

Figure 5G-2.10: Iowa Jointed Reinforced Pavement Detail - 31' Back-To-Back Street

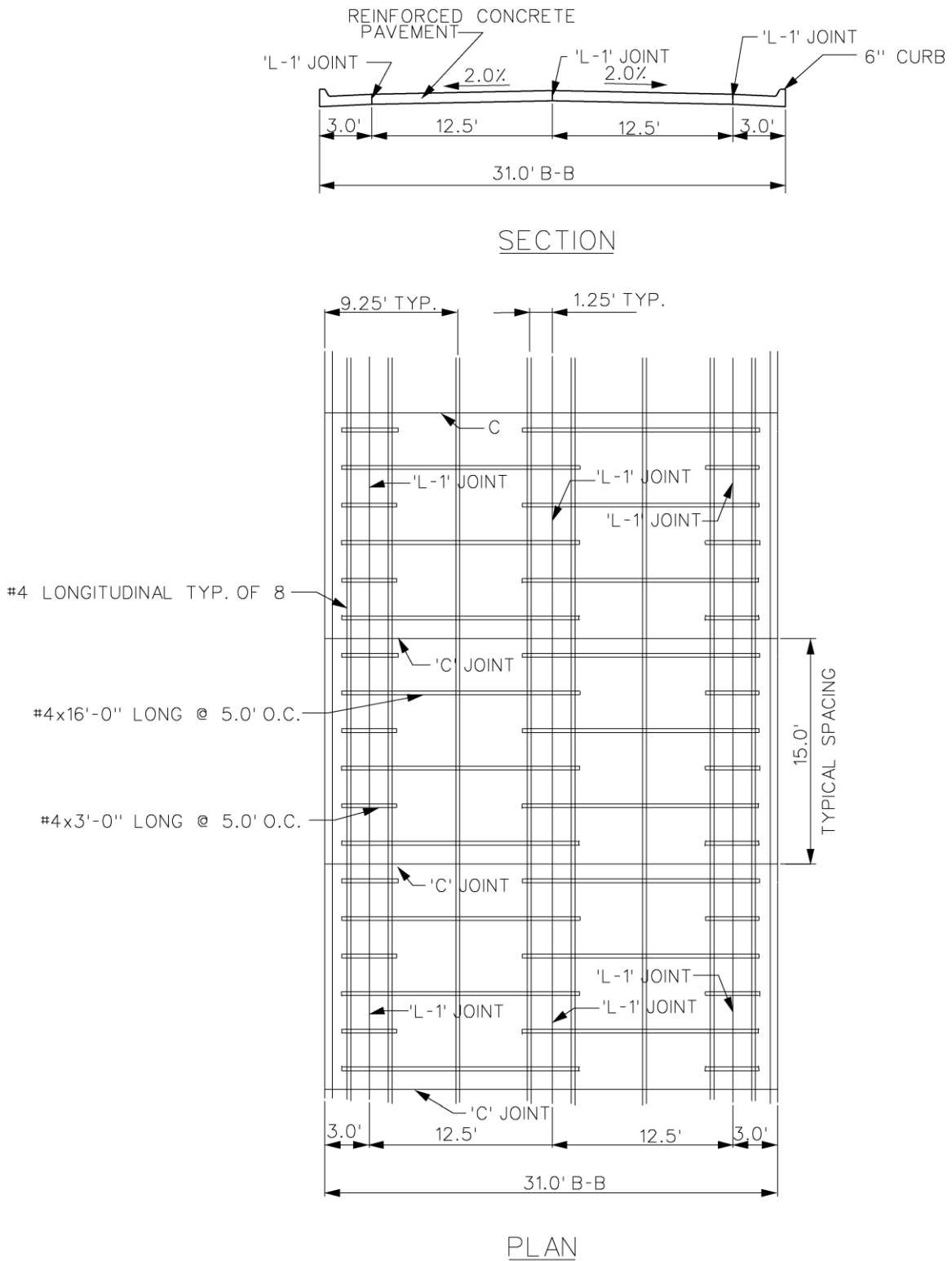

Figure 5G-2.12: 49' B/B and 53' B/B C&G/HMA Pavement

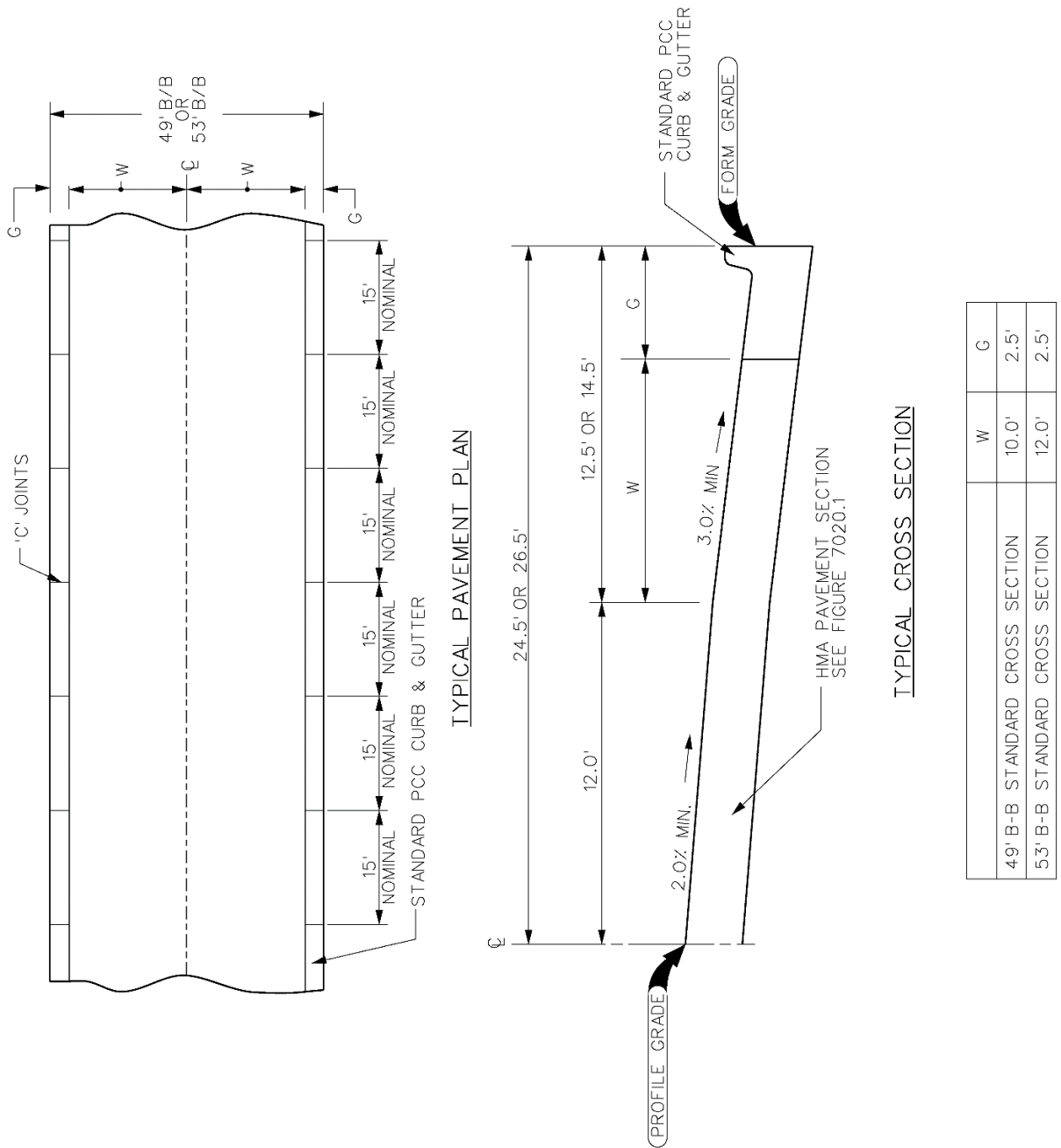

Figure 5G-2.13: 24' Rural PCC Pavement Jointing and Crown Detail

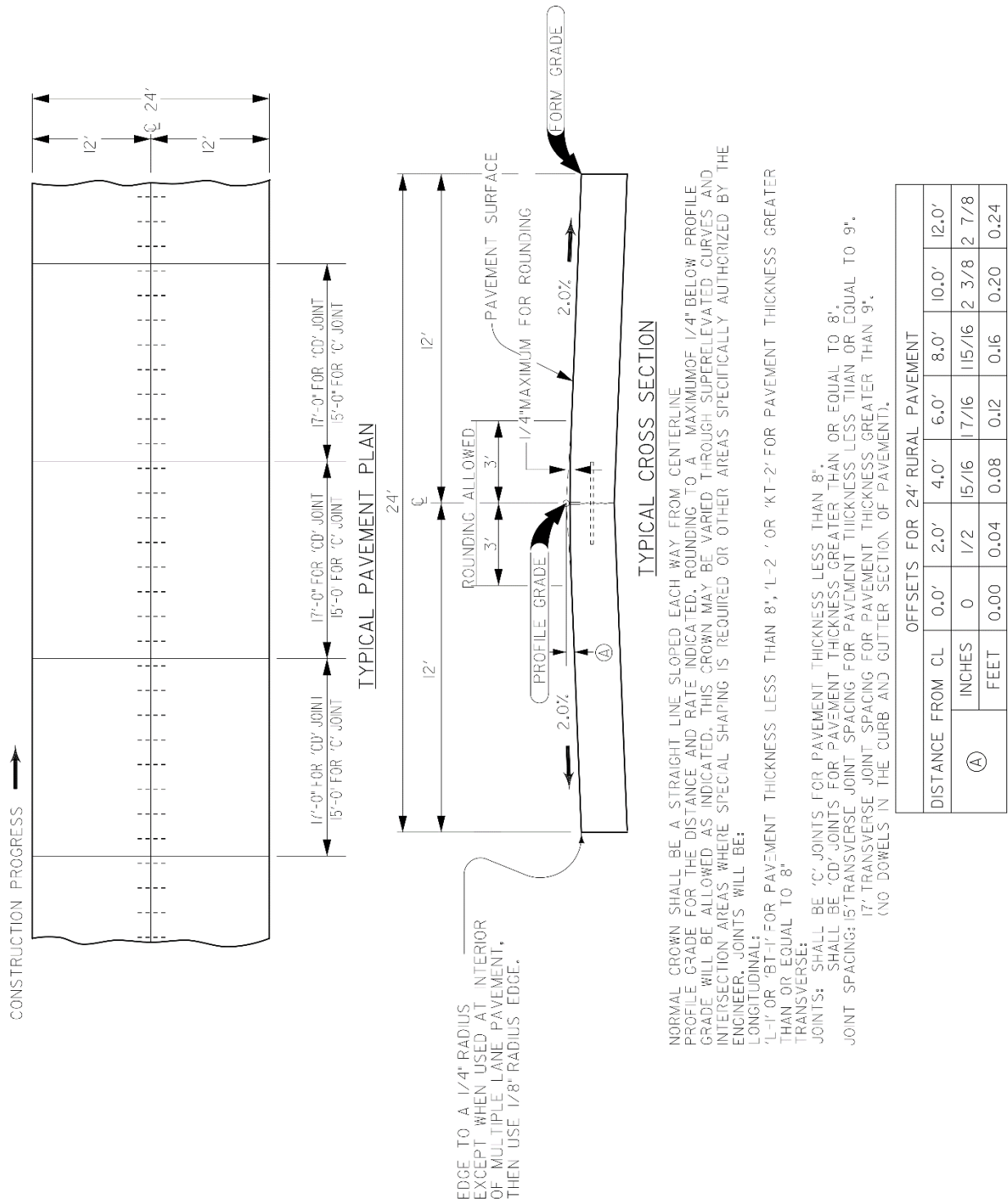
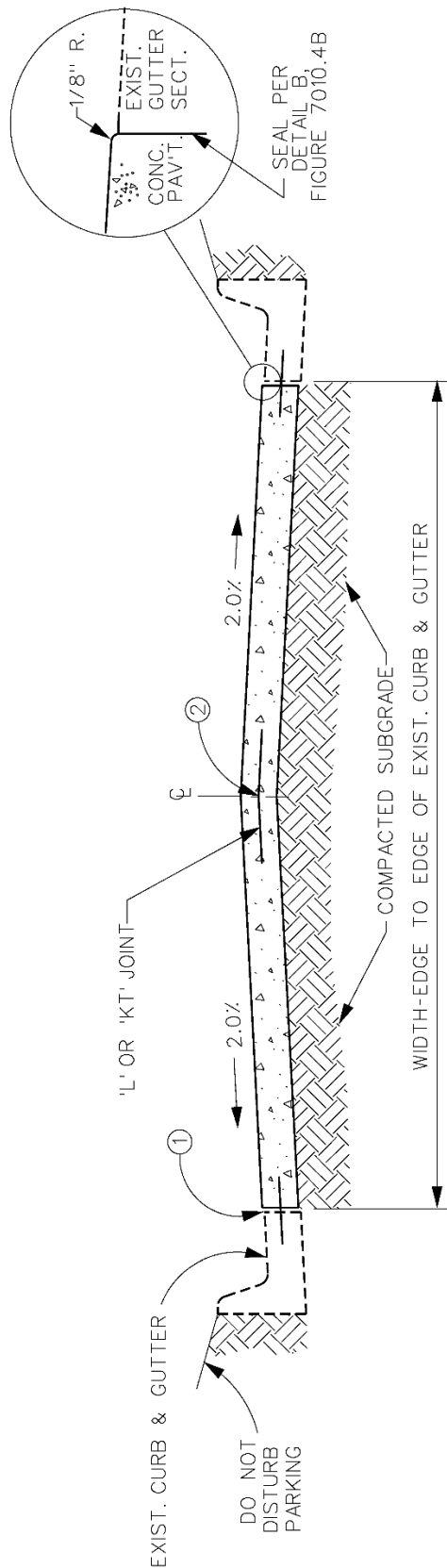

Figure 5G-2.15: PCC Pavement Section Between Existing Curb and Gutter



FOR CROWN SEE FIGURES 7010.1A (SHEET 1 OR 2) OR 7010.1B

- ① 'BT-1' JOINT IF PAVEMENT THICKNESS IS LESS THAN 8"; 'BT-2' JOINT IF PAVEMENT THICKNESS IS 8" OR GREATER.
- ② 'L-1' OR 'BT-1' JOINT IF PAVEMENT THICKNESS IS LESS THAN 8"; 'L-2' OR 'KT-2' JOINT IF PAVEMENT THICKNESS IS 8" OR GREATER.

G. References

Portland Cement Association. *Portland Cement Association Manual*.1992.