

MAST ARM POLE FOUNDATION IN SOIL TYPE A FOUNDATION

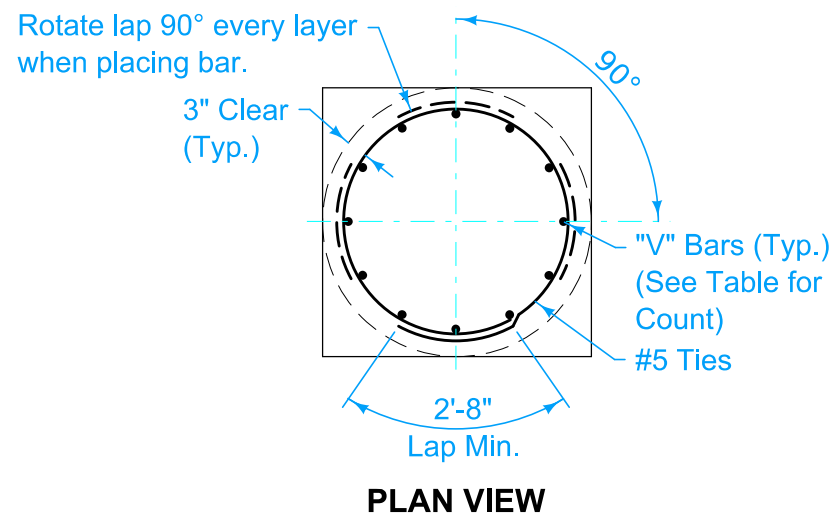

PLAN VIEW

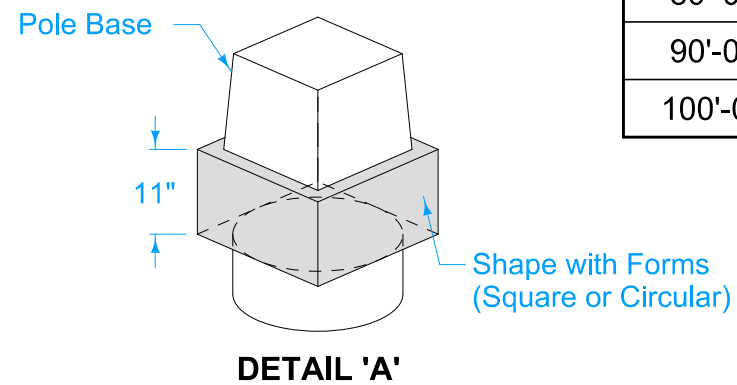

DETAIL 'A'

The Type A Foundation is the normally required foundation construction. Where rock is encountered, the Engineer may approve the use of the Type B or C Foundation. Prior to installing a foundation in rock, obtain a subsurface investigation certified by a geotechnical engineer licensed in the State of Iowa.

Ties may be welded to vertical bars. Ties may be replaced with spirals of the same size and pitch. Anchor spirals with 1 1/2 turns at the top and bottom of the spiral.

- ① Shape top 11 inches with forms. See Detail 'A'.
- ② Install rodent guard or non-shrink grout with weep hole.
- ③ Furnish nut, nut and plate, or nut and anchor bolt assembly ring plate on embedded end. Tighten anchor-bolt nuts according to the specifications.
- ④ Provide conduits as per plans.
- ⑤ Install ground rod adjacent to foundation or in adjacent handhole.

Max. Mast Arm Length	Foundation		"V" Bars			Tie Bars		
	① Min.	② Min.	Count	Size	Length	Count	Max. Spacing	
							# Spaces	③
35'-0"	3'-6"	13'-0"	10	#10	12'-6"	14	13	12"
45'-0"	3'-6"	16'-0"	10	#10	15'-6"	17	16	12"
55'-0"	3'-6"	19'-0"	10	#10	18'-6"	20	19	12"
60'-0"	3'-6"	21'-0"	10	#10	20'-6"	22	21	12"
70'-0"	4'-0"	21'-0"	12	#11	20'-6"	22	21	12"
80'-0"	4'-0"	25'-0"	12	#11	24'-6"	26	25	12"
90'-0"	4'-6"	25'-0"	14	#11	24'-6"	31	30	10"
100'-0"	4'-6"	31'-0"	14	#11	30'-6"	38	37	10"

		REVISION	
		6	xx-xx-xx
FIGURE 8010.102	STANDARD ROAD PLAN	TS-102	
SHEET 1 of 4			
REVISIONS: Removed hooks from foundation reinforcing. Updated notes for conduit installation. Clarified placement of ground rod. Updated for LRFD.			
 SUDAS DIRECTOR		 DESIGN METHODS ENGINEER	
TRAFFIC SIGNAL POLE FOUNDATION			

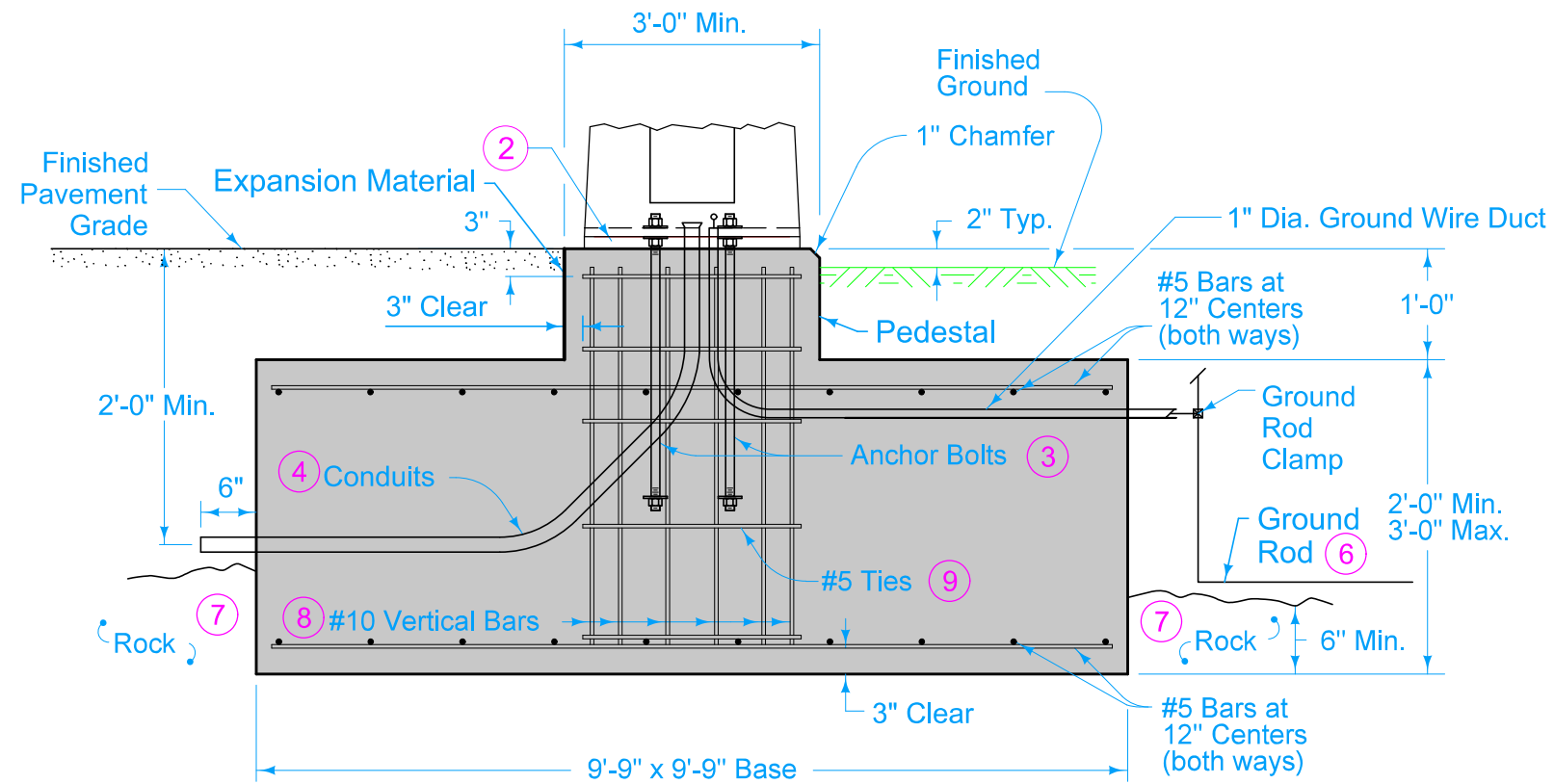

**MAST ARM POLE FOUNDATION IN ROCK
TYPE B FOUNDATION**

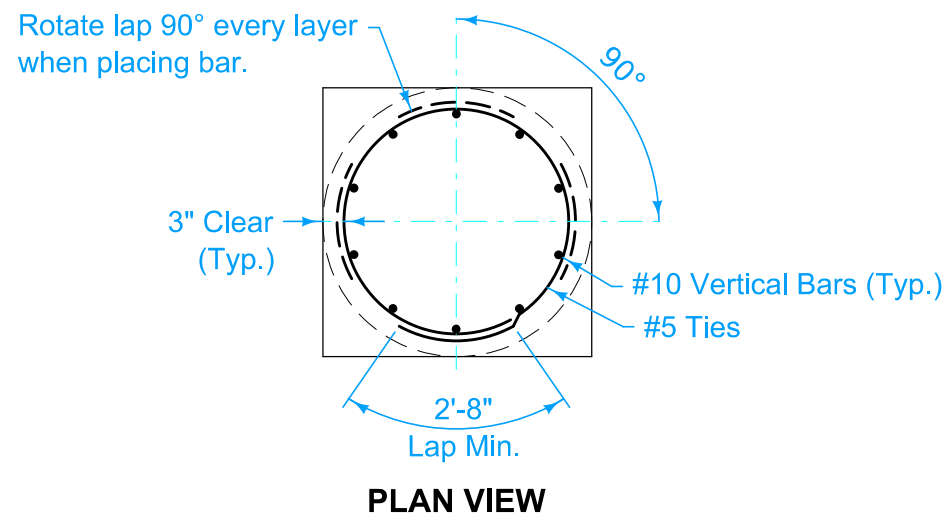

Type B Foundation is applicable for traffic signal poles with mast arm lengths up to 60 feet.

If the excavation for a Type B Foundation is left open for more than 1 calendar day, install temporary barrier rail if any part of the excavation is located within the clear zone. Temporary barrier rail layout requires the Engineer's approval.

Competent rock has an average unconfined compressive strength (q_u) of at least 2.0 ksi and rock quality designation of at least 75%. Conditions not meeting these minimum requirements will require either:

- A site specific design, or
- Using a Type A or Type C Foundation.

- 2 Install rodent guard or non-shrink grout with weep hole.
- 3 Furnish nut, nut and plate, or nut and anchor bolt assembly ring plate on embedded end. Tighten anchor-bolt nuts according to the specifications.
- 4 Provide conduits as per plans.
- 6 When in contact with rock, place ground rods as specified in National Electrical Code, current edition, adjacent to foundation or in adjacent handhole.
- 7 Cast foundation concrete against competent rock. If foundation is formed, place backfill with concrete cast against rock.
- 8 Place 10 equally spaced #10 vertical bars.
- 9 #5 bars spaced at 12 inch maximum. Ties may be welded to vertical bars. Ties may be replaced with spirals of the same size and pitch. Anchor spirals with 1 1/2 turns at the top and bottom of the spiral.

		REVISION	
		6	xx-xx-xx
FIGURE 8010.102	STANDARD ROAD PLAN	TS-102	
		SHEET 2 of 4	

REVISIONS: Removed hooks from foundation reinforcing. Updated notes for conduit installation. Clarified placement of ground rod. Updated for LRFD.

SUDAS DIRECTOR
 DESIGN METHODS ENGINEER

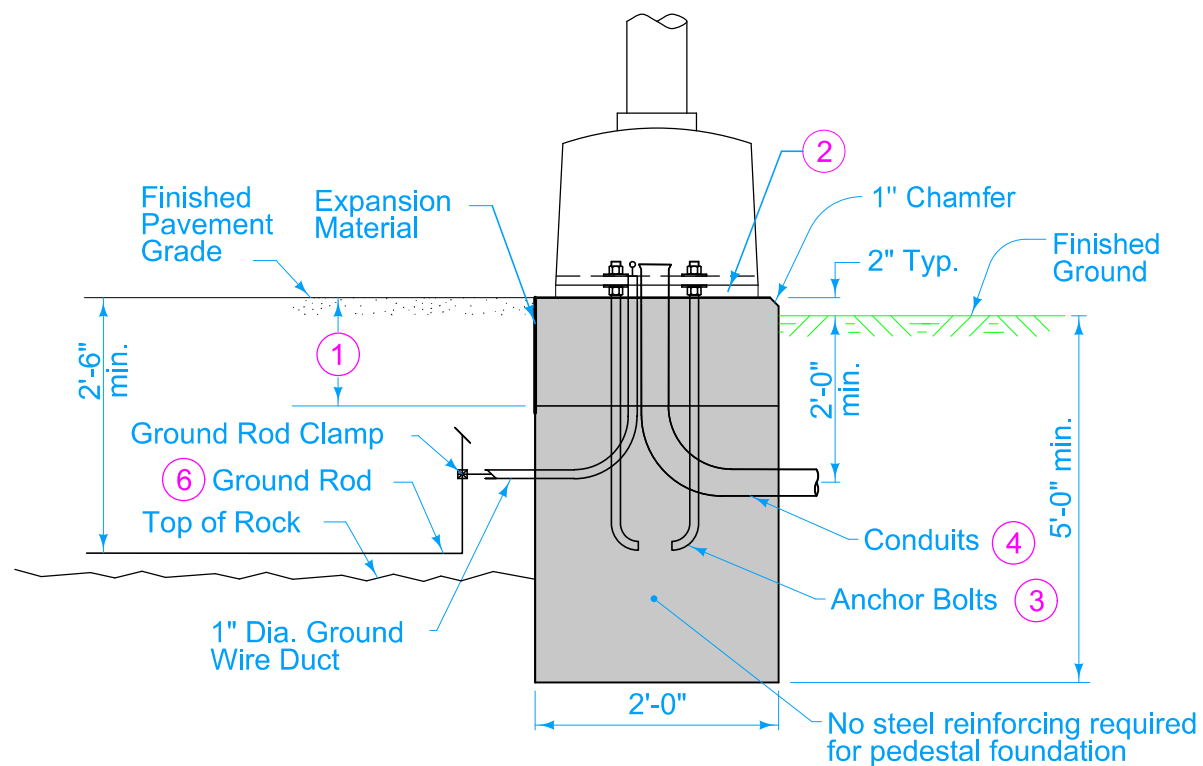

PEDESTAL POLE FOUNDATION IN SOIL OR ROCK

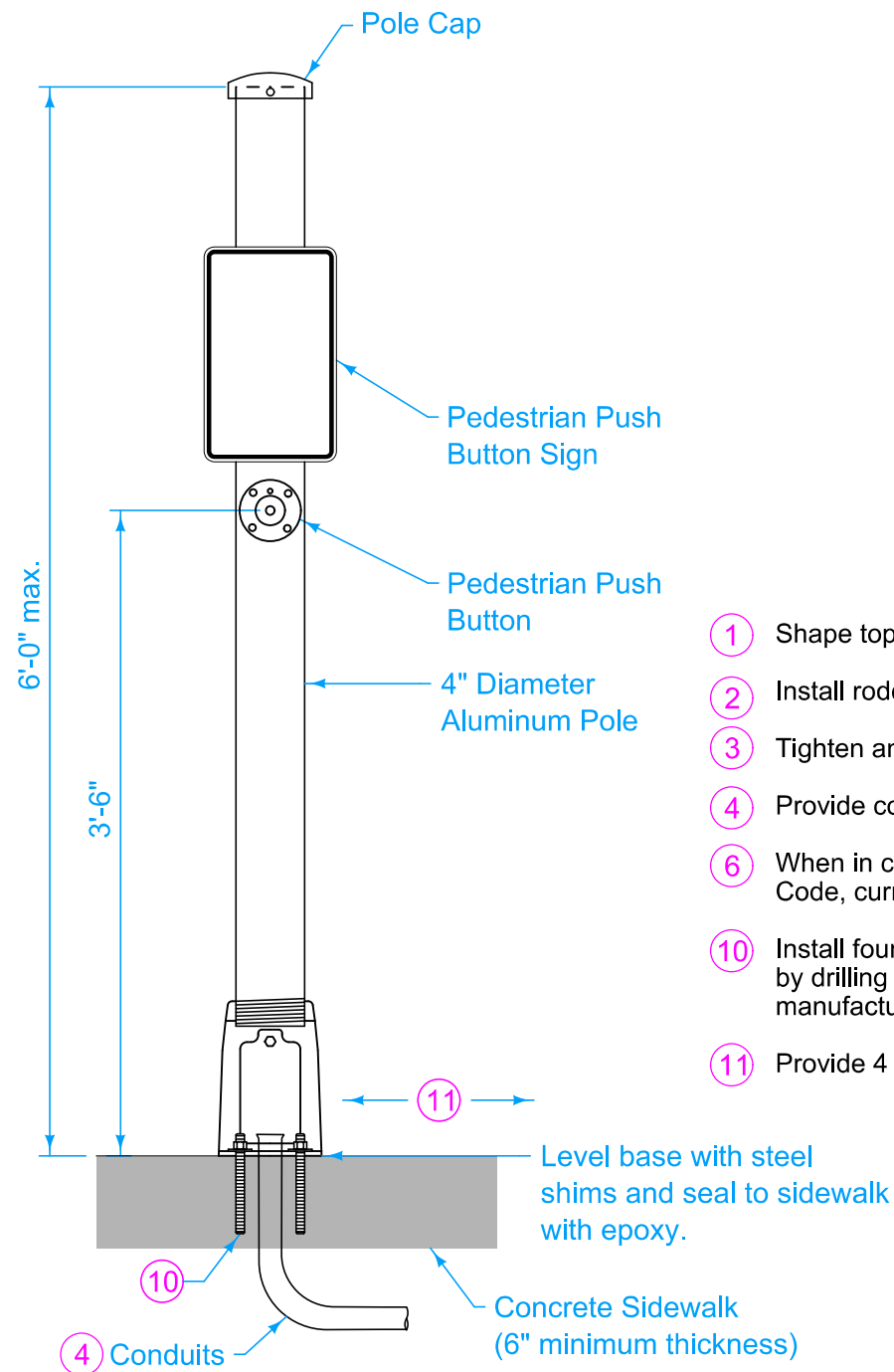
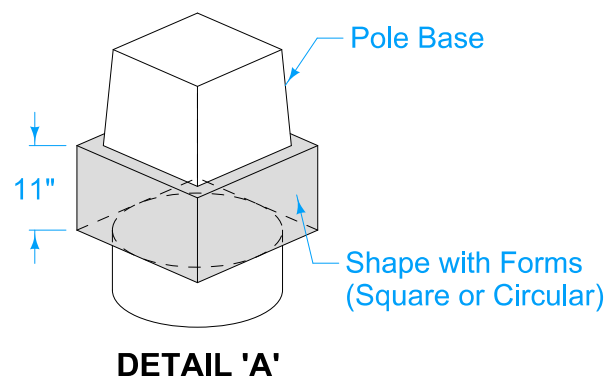

ALTERNATE PUSH BUTTON POLE SIDEWALK MOUNTING

The depicted traffic signal pole foundation was designed based on the following values and/or conditions. In cases where these required values and/or conditions are not met, a special foundation is required.

The water table is assumed to be below the bottom of the foundation.

The pedestal pole foundation shown on this sheet has been designed for the following assumed soil parameters:

Cohesive Soil:
 Min. shear strength: $c = 0.75 \text{ ksf}$
 Min. unit weight of soil: $\gamma = 120 \text{ pcf}$

Cohesionless Soil:
 Min. angle of friction: $\phi = 30 \text{ deg}$
 Min. unit weight of soil: $\gamma = 115 \text{ pcf}$

The pedestal pole is designed for a 5-section signal head and the maximum factored design loading for the pedestal pole foundation is:

Overturning moment: 14.7 kip-ft
 Torsional moment: 0.8 kip-ft
 Axial force = 0.7 kip
 Shear force = 0.8 kip

- ① Shape top 11 inches with forms. See Detail 'A'.
- ② Install rodent guard or non-shrink grout with weep hole.
- ③ Tighten anchor-bolt nuts according to the specifications.
- ④ Provide conduits as per plans.
- ⑥ When in contact with rock, place ground rods as specified in National Electrical Code, current edition, adjacent to foundation or in adjacent handhole.
- ⑩ Install four anchor bolts, washers, and nuts in new or existing concrete sidewalk by drilling and anchoring with epoxy adhesive. Provide bolts according to manufacturer's recommendations.
- ⑪ Provide 4 foot accessible path adjacent to push button pole.

		REVISION	
		6	XX-XX-XX
FIGURE 8010.102	STANDARD ROAD PLAN	TS-102 SHEET 4 of 4	
REVISIONS: Removed hooks from foundation reinforcing. Updated notes for conduit installation. Clarified placement of ground rod. Updated for LRFD.			
 SUDAS DIRECTOR		 DESIGN METHODS ENGINEER	